

• April 21 Notes

Light Transmission Metrics
- Sine wave
- Amplitude is Power

Amplitude

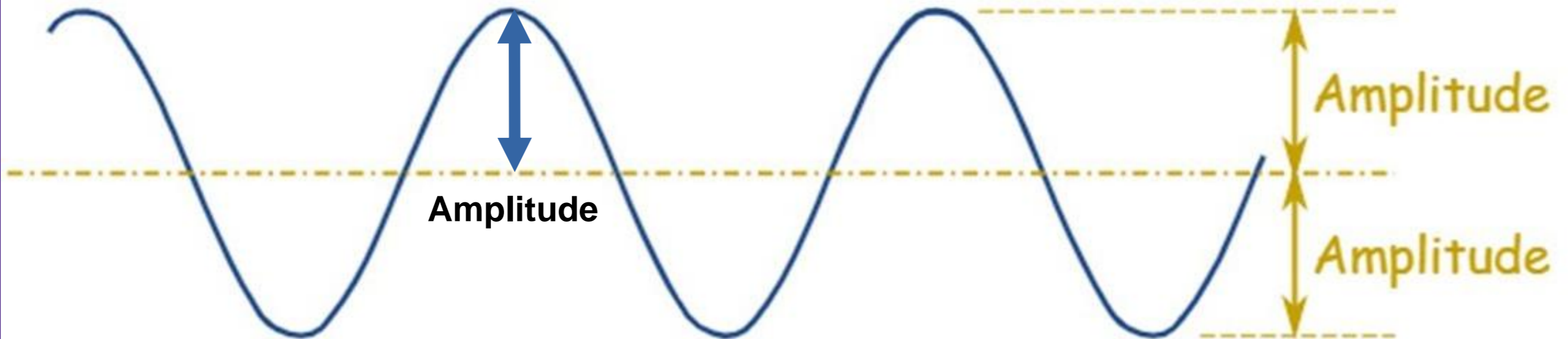

1 cycle

Beginning to End

- 0 to 360 degrees is one cycle
- Number of cycles per second = frequency
 - Frequency is measured in Hz
- Eg: 10kHz = 10,000 cycles per second

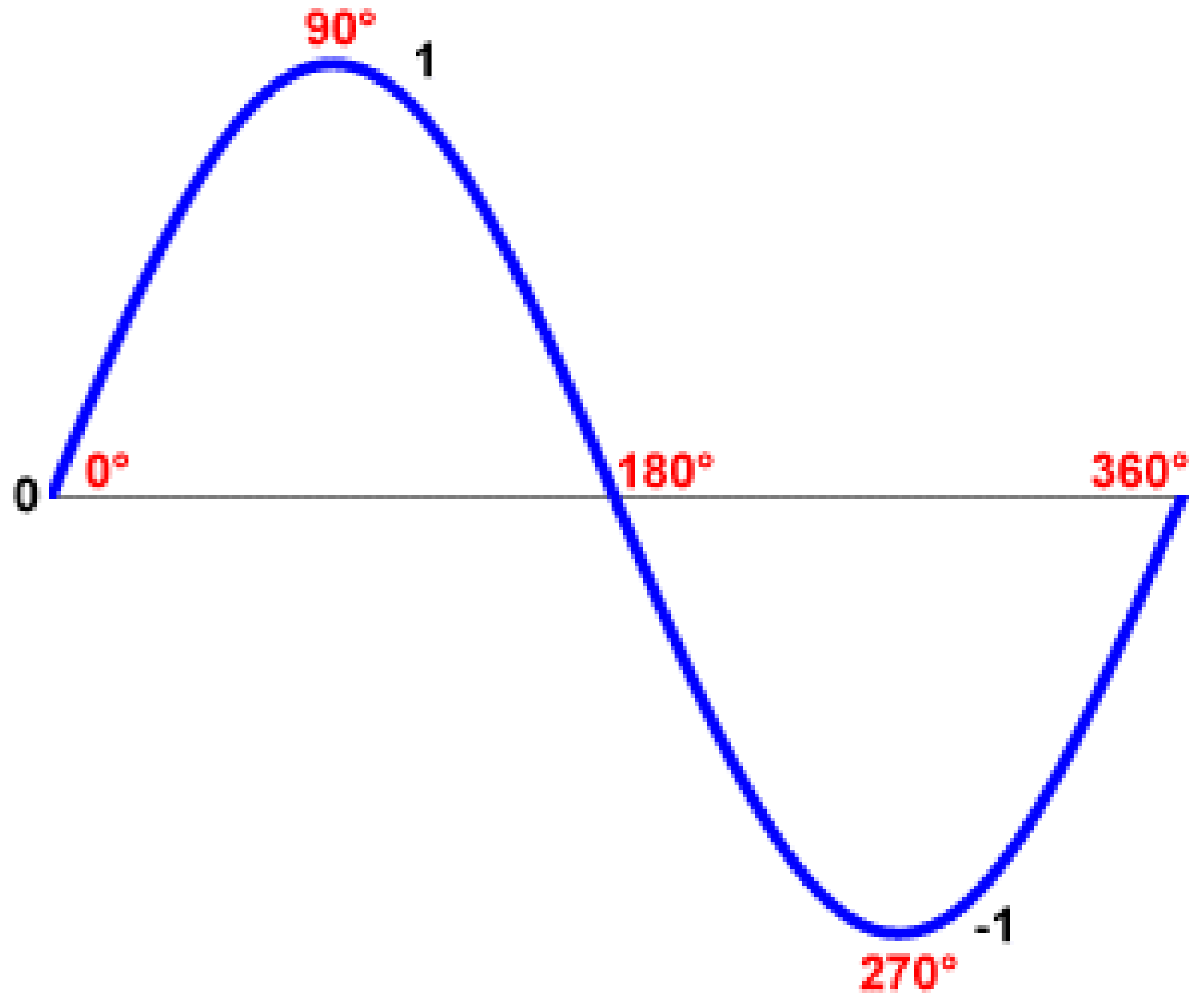

- Change in frequency: change what is being carried
- 2 audio signals

Sine Wave Frequency Variations

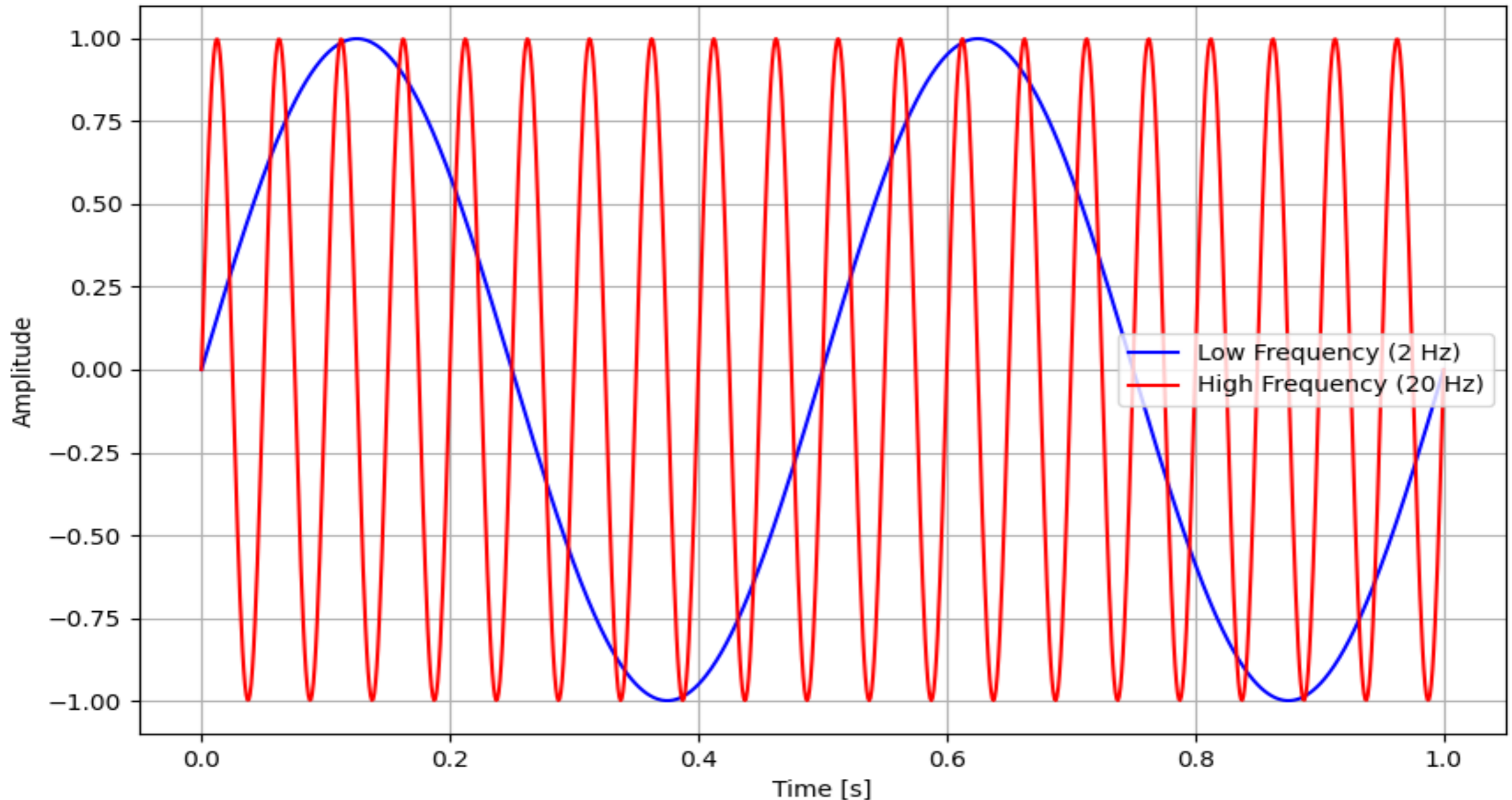

- Higher voice = higher frequency ie: opera; higher pitch
- Amplitude = loudness

- 2 audio signals out of phase

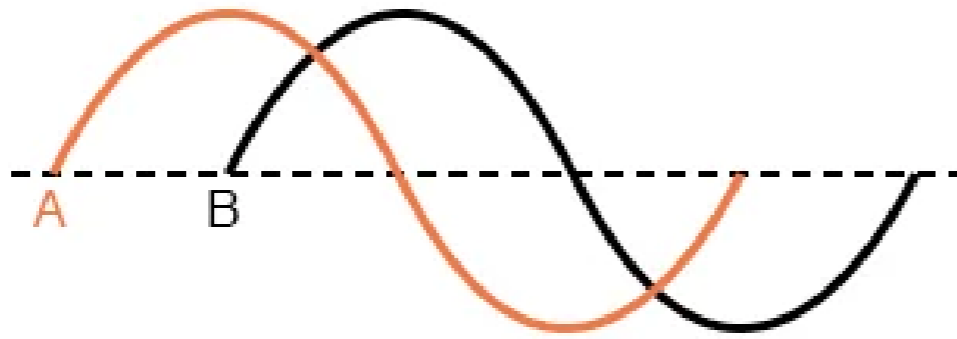

Phase shift = 90 degrees
A is ahead of B
(A "leads" B)

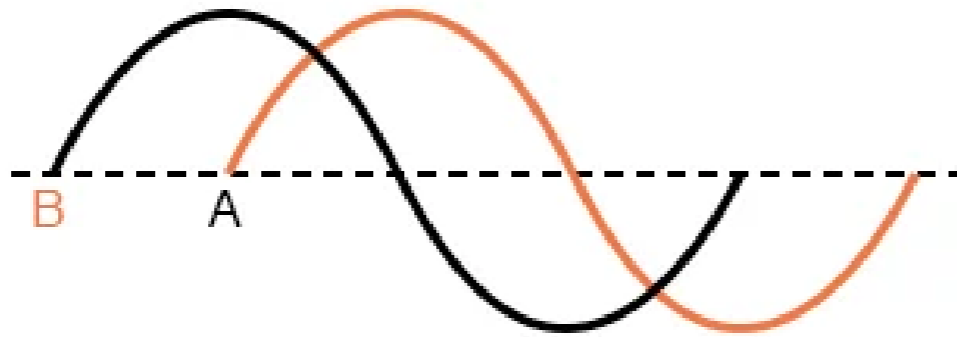

Phase shift = 90 degrees
B is ahead of A
(B "leads" A)

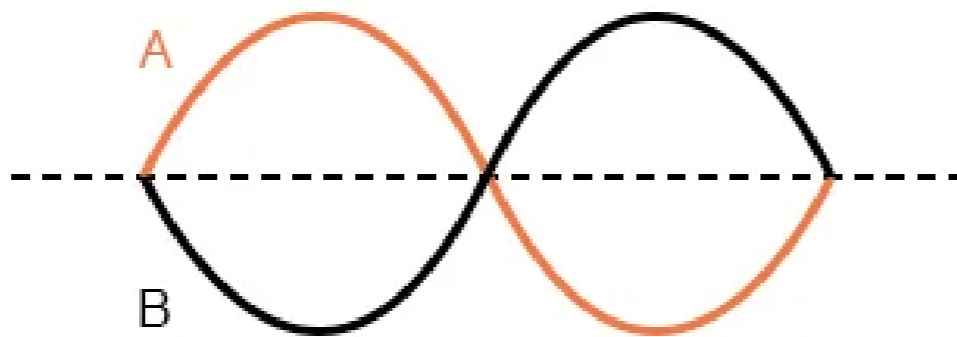

Phase shift = 180 degrees
A and B waveforms are
mirror-images of each other

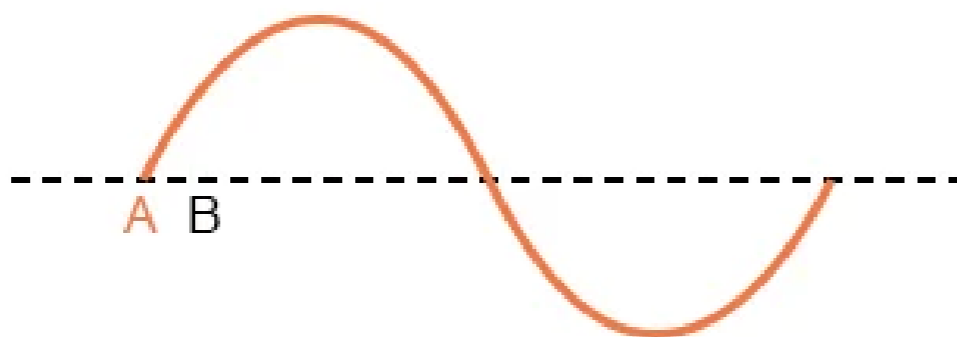

Phase shift = 0 degrees
A and B waveforms are in
perfect step with each other

- 180 degrees out of phase
- Signals cancel out, ie: "Tug of war"
- Noise cancellation headphones use this method

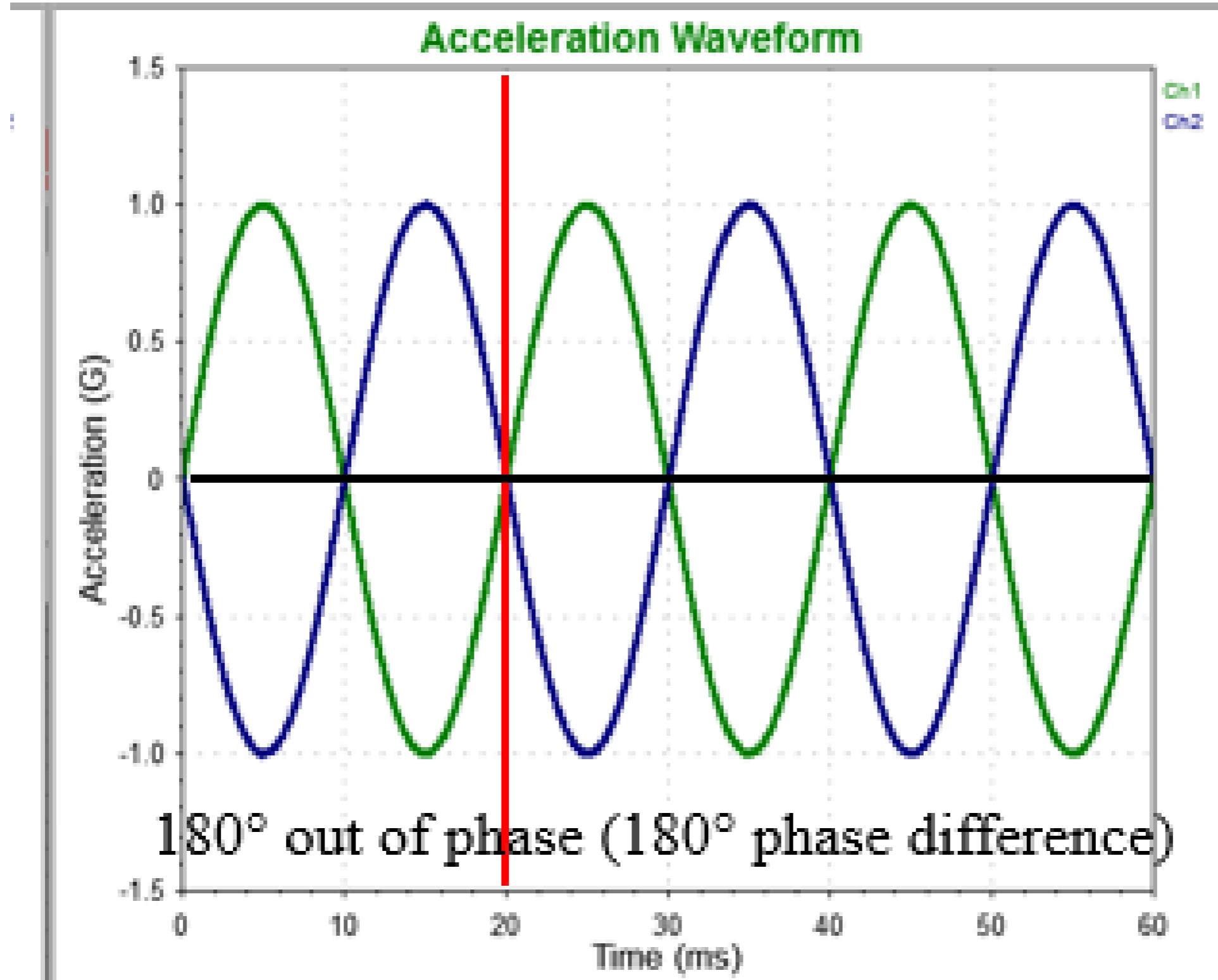

- 180 degrees out of phase
- Signals cancel out, ie: "Tug of war"
- Noise cancellation headphones use this method

INSIDE NOISE-CANCELLING HEADPHONES

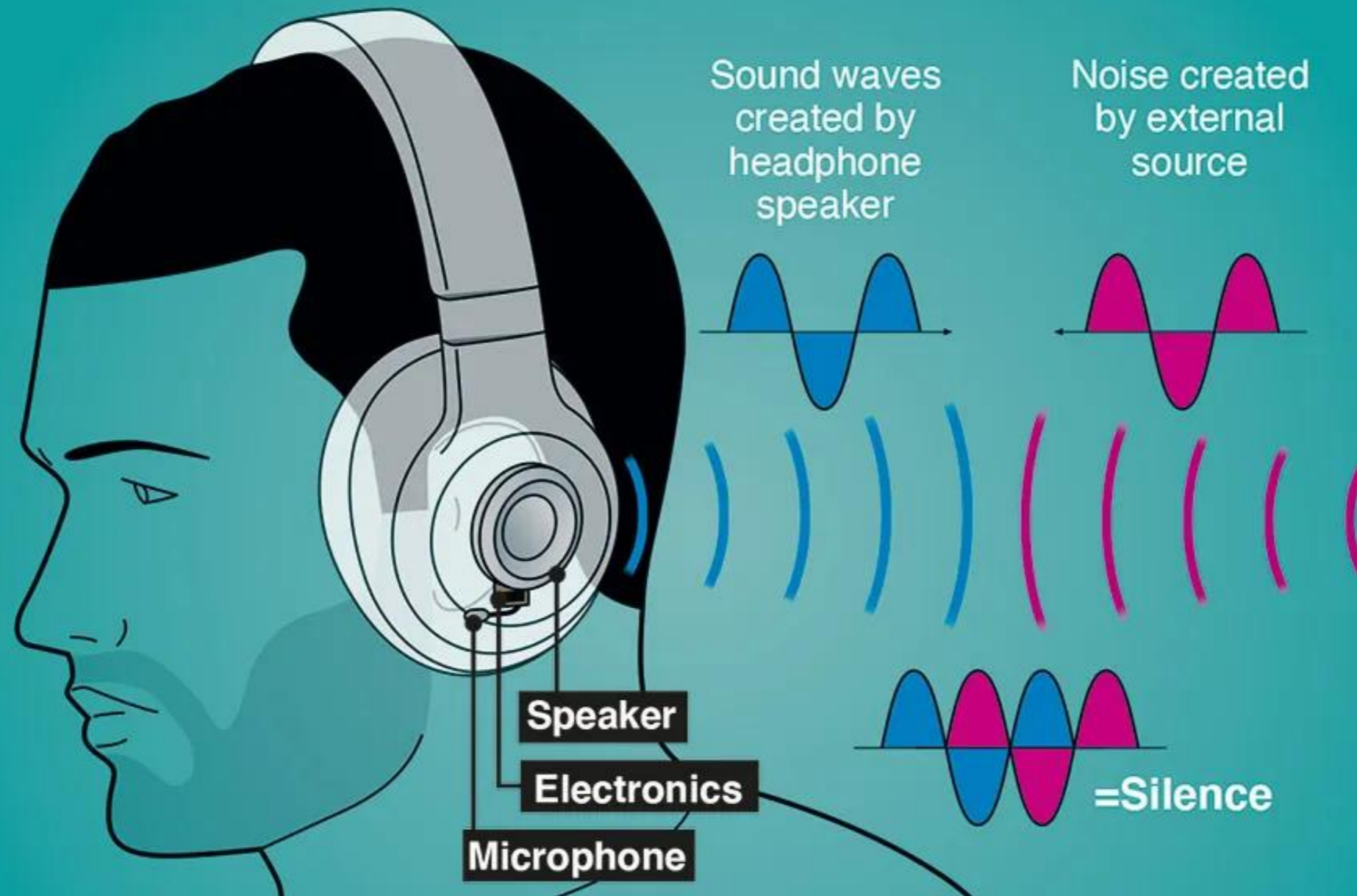

- 1 cycle per 1 second = 1 Hz

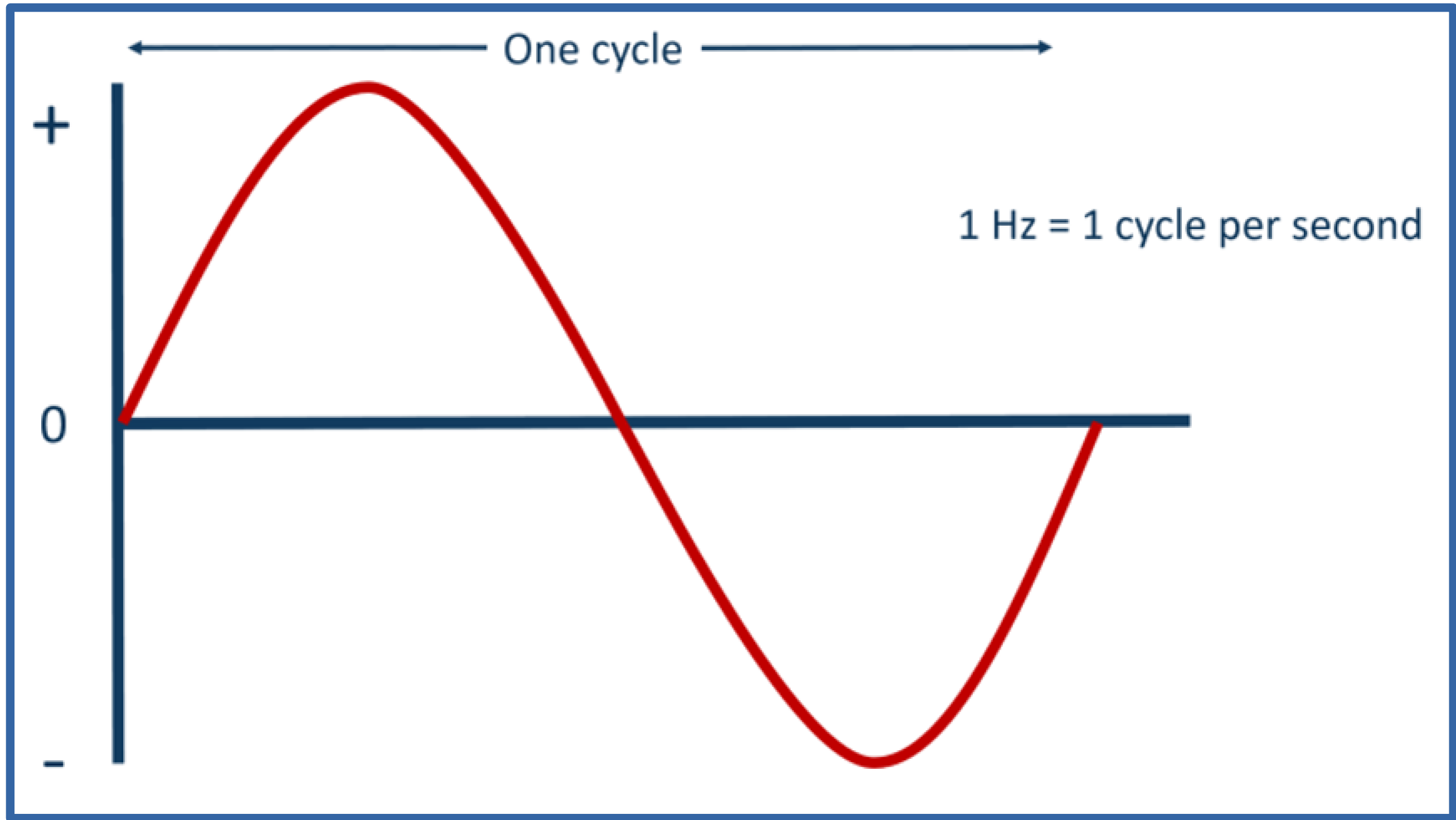

- 2 cycles per 1 second = 2 Hz

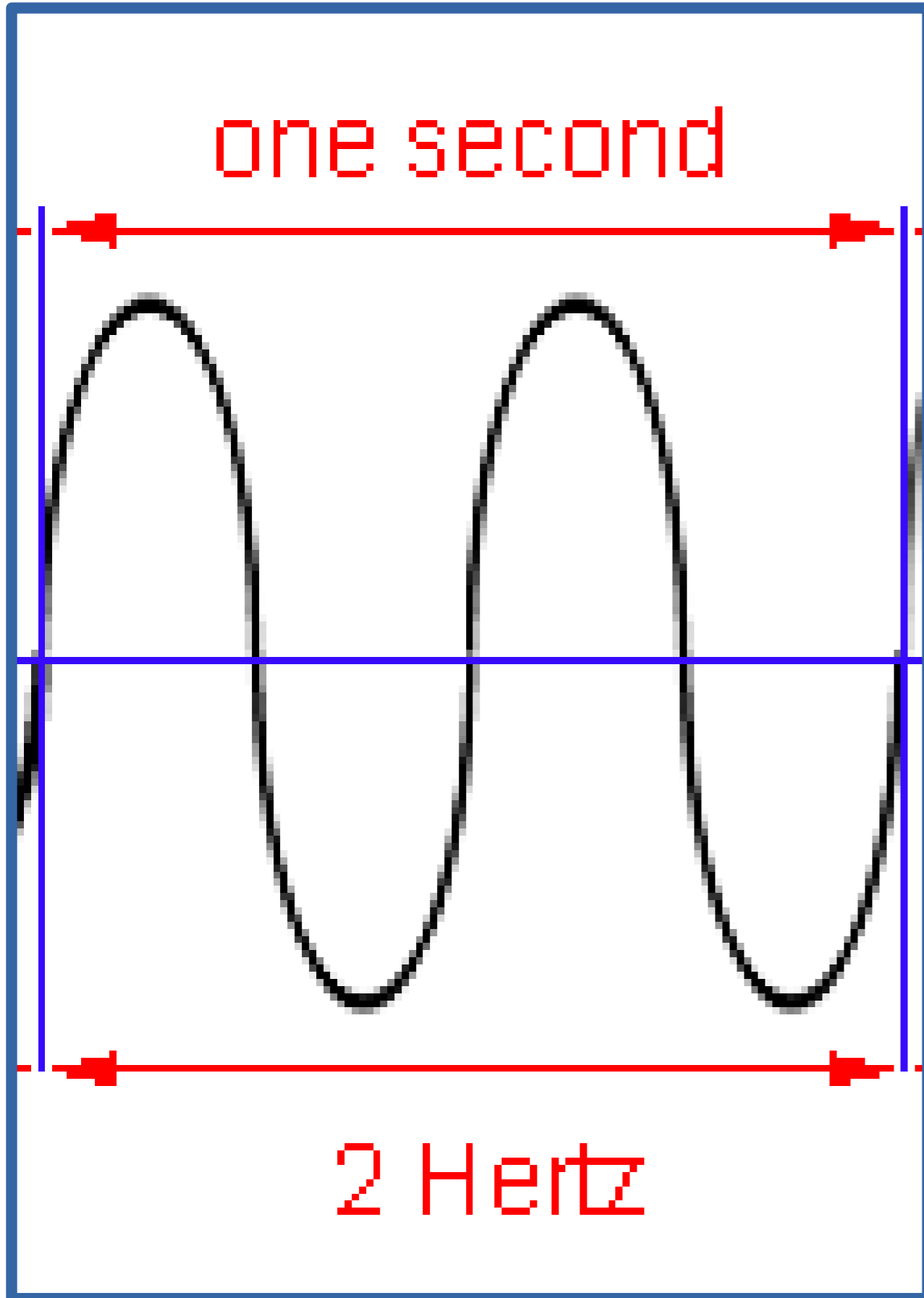

- 4 cycles per 1 second = 4 Hz

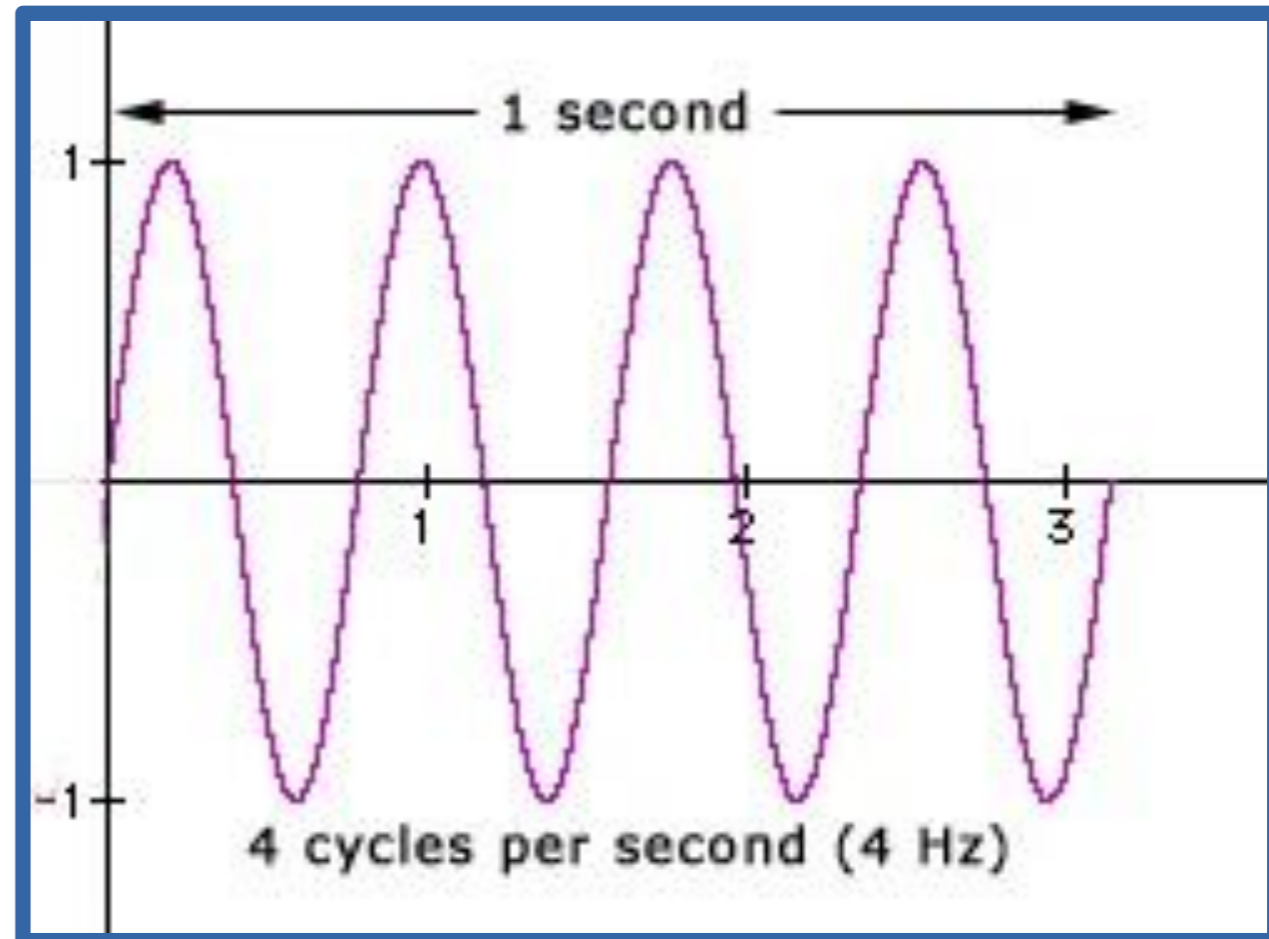

- Double the cycles
- Change in frequency NOT amplitude

- 100 cycles per 1 second = 100 Hz

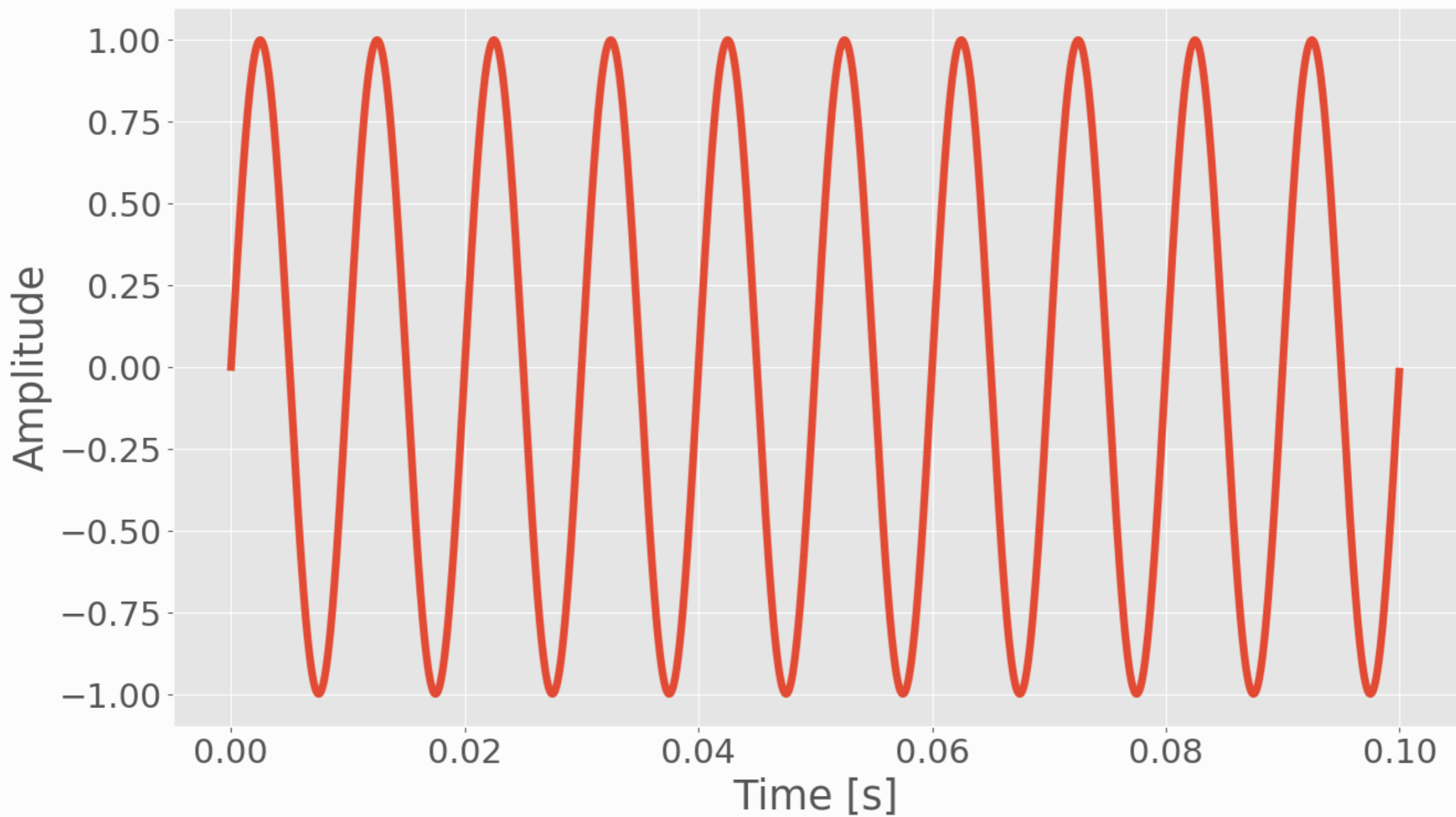

- Light waves

- Go from shorter to longer wavelength
- Shorter wavelength shifts towards Blue color
- Longer wavelength shifts towards Red color

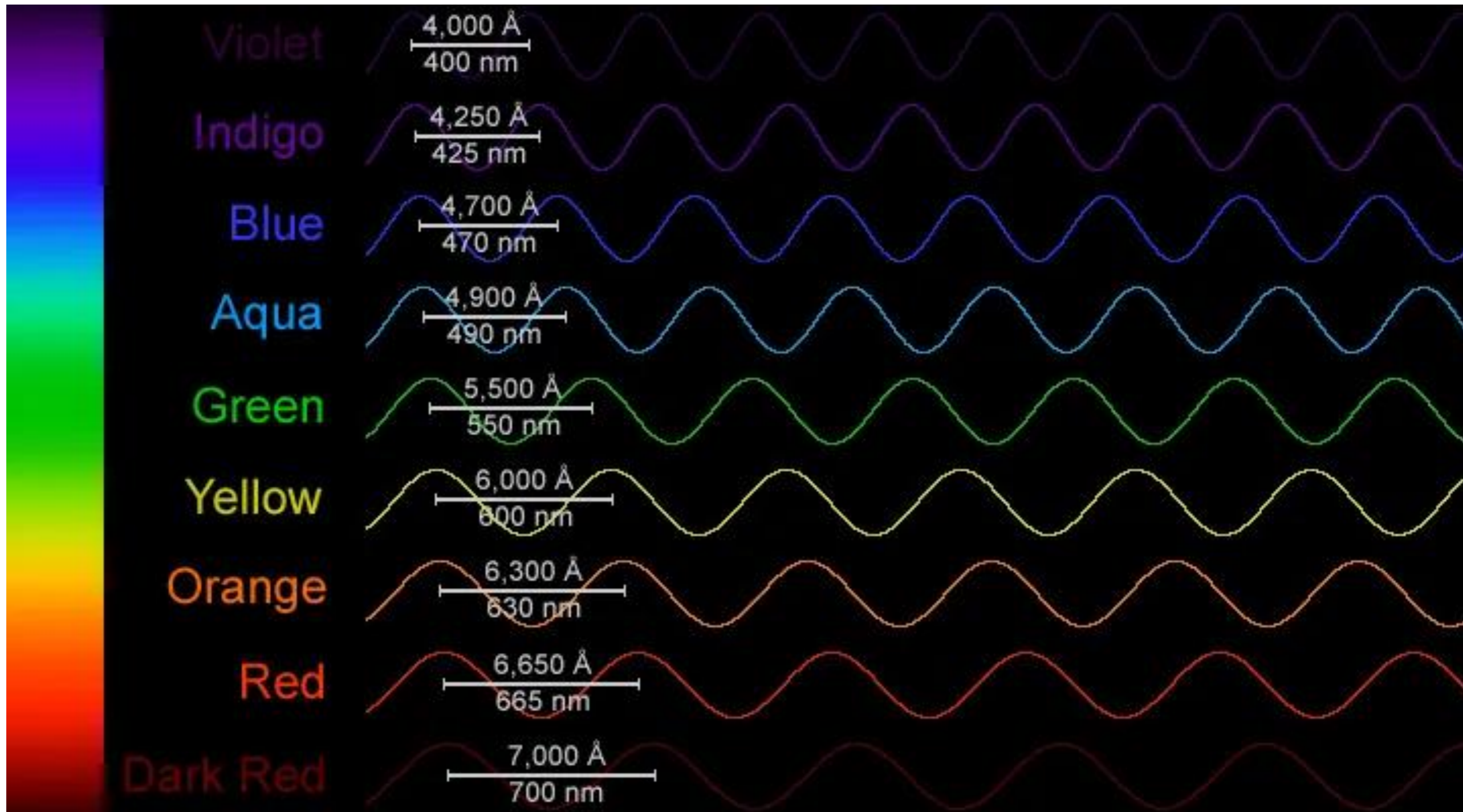

- Multimode fiber > used for short distances
 - Multiple signals at one time
 - Bounces light off wall of cable
 - Carries light waves; 50 micron core

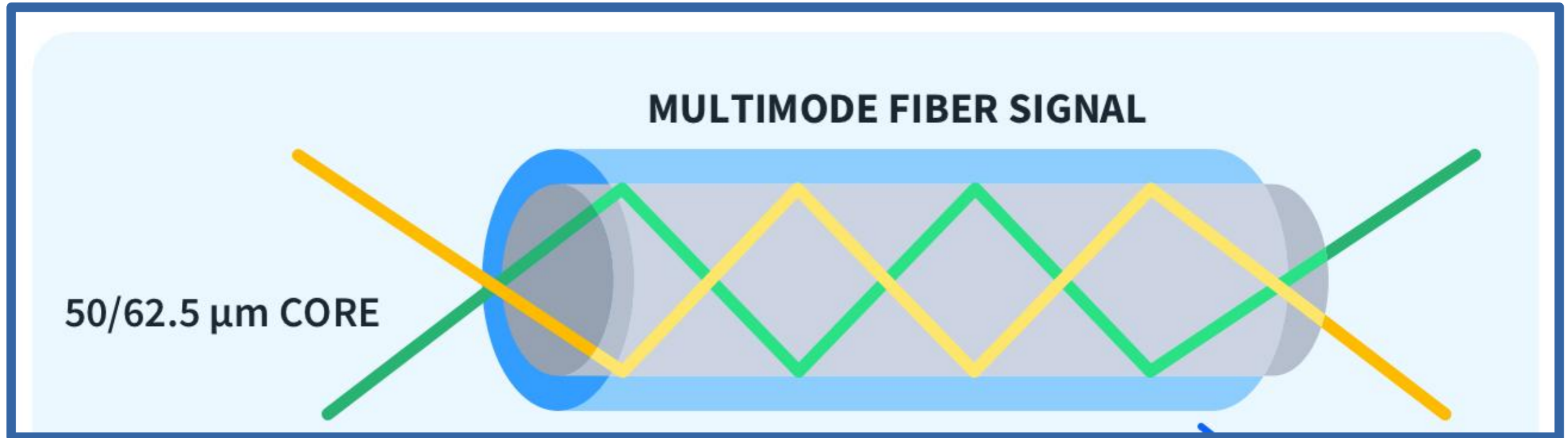

Multimode

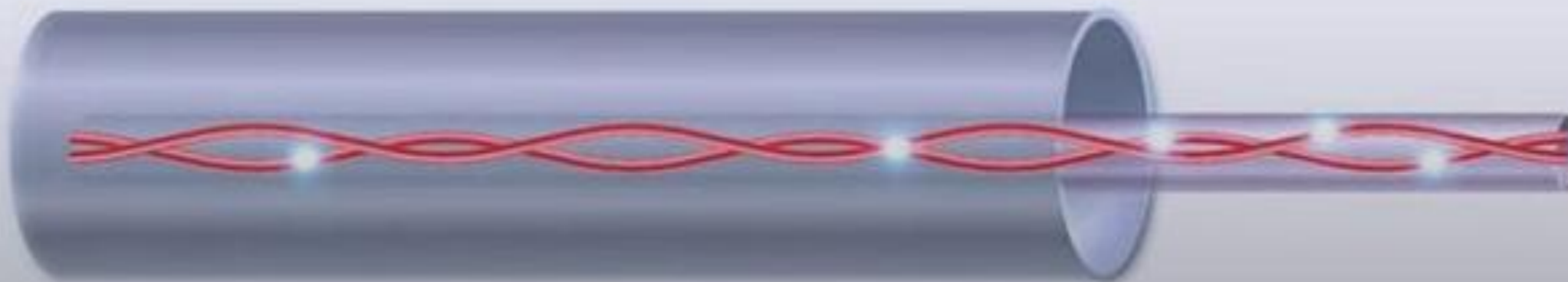

50 μm Diameter

- Multimodal dispersion
- Light waves arrives at 2 different times

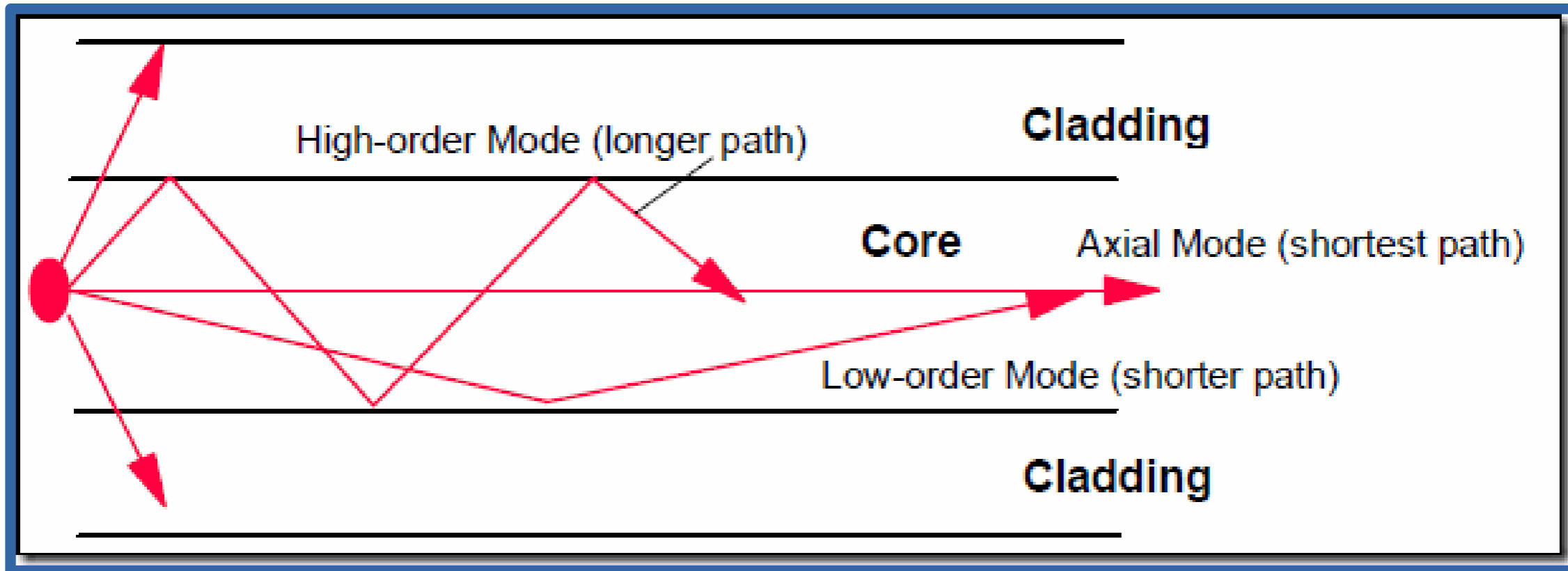

Modal Dispersion

High-Order Mode
(longer path, more
modal dispersion)

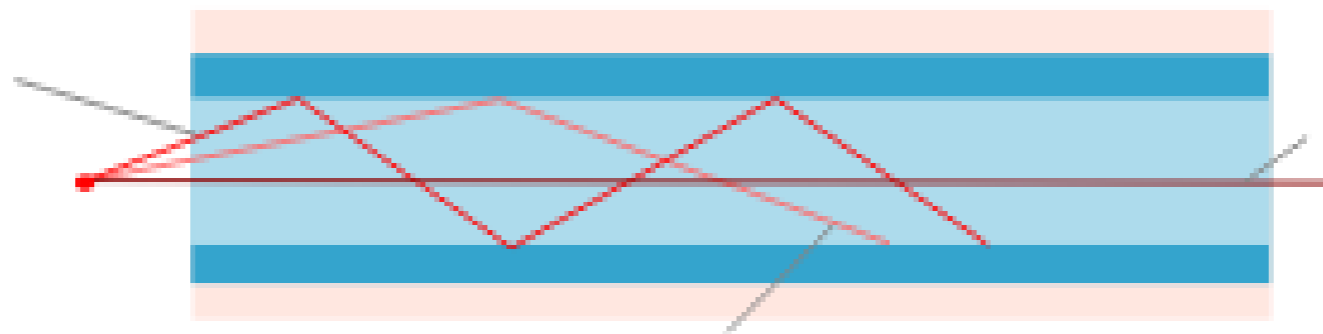

Axial-Mode (shortest
path, zero modal
dispersion)

Low-Order Mode
(shorter path, less
modal dispersion)

- Multimodal dispersion
- Light waves arrives at 2 different times

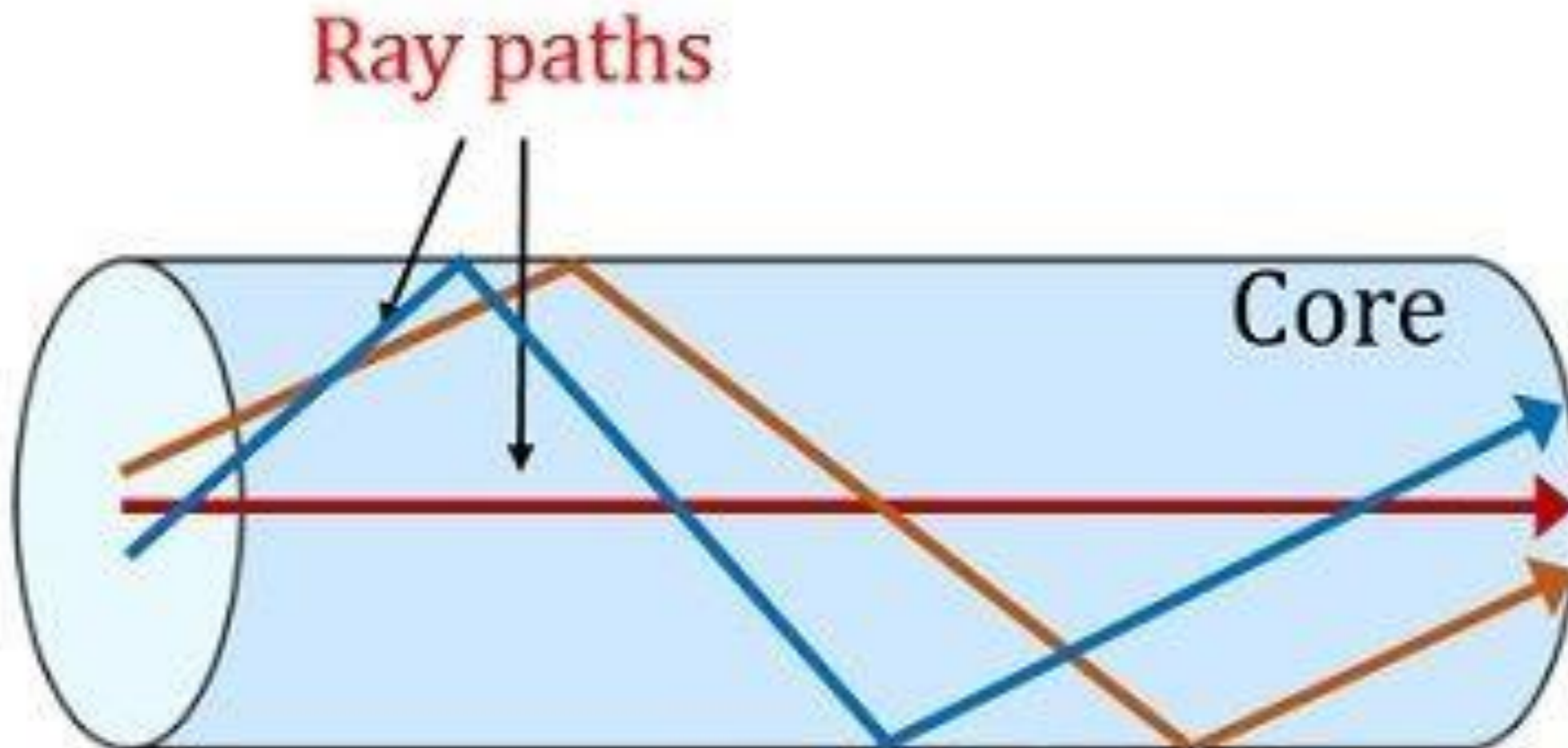

Intermodal dispersion where light rays propagate through different paths hence their reaching time at the destination is different.

- Singlemode fiber > used for long distance
 - Single signal at one time
 - 8.3 micron core
- Carries signal 100 to 200 km without amplification

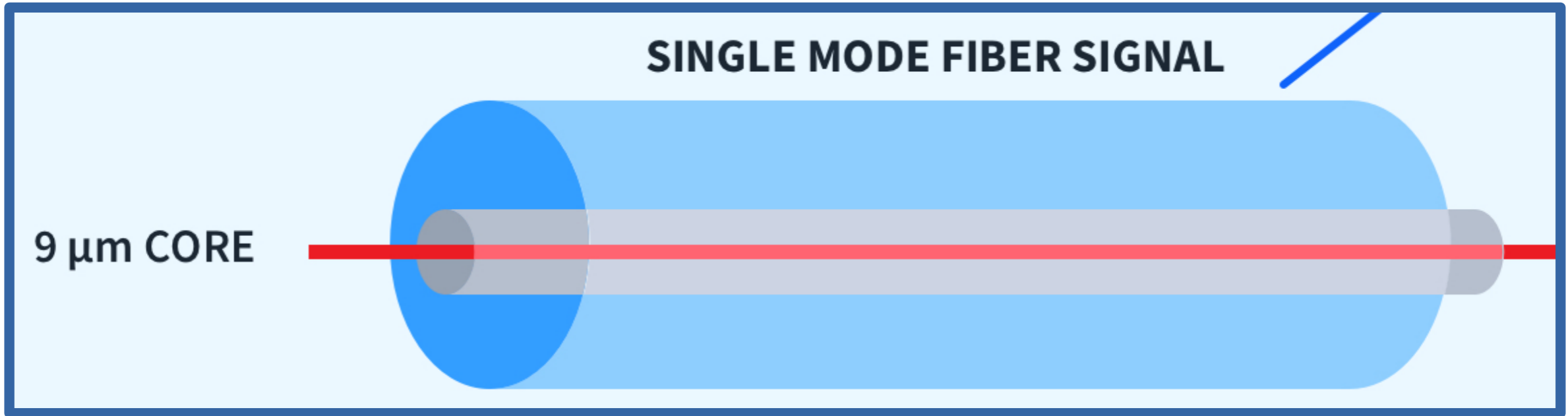

Single-Mode

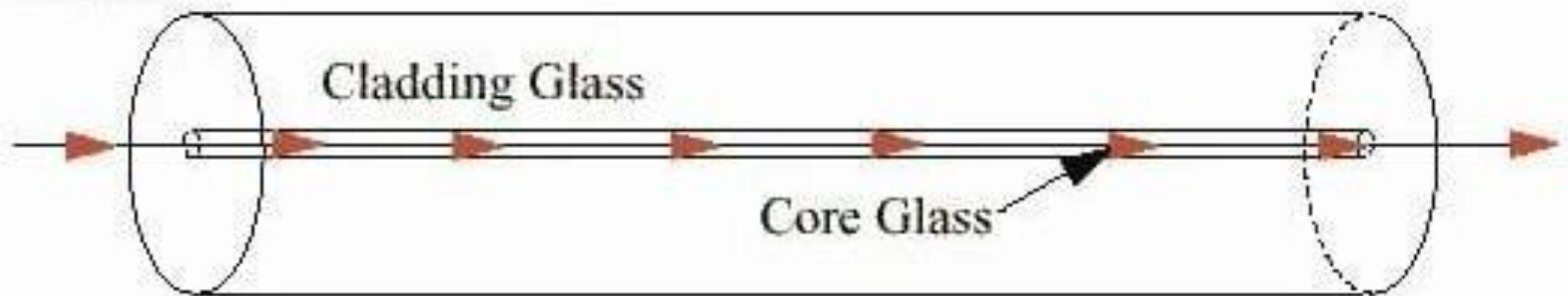

- Link Aggregation
- Doubles bandwidth
- Increases speed not distance
- “2 lane highway”

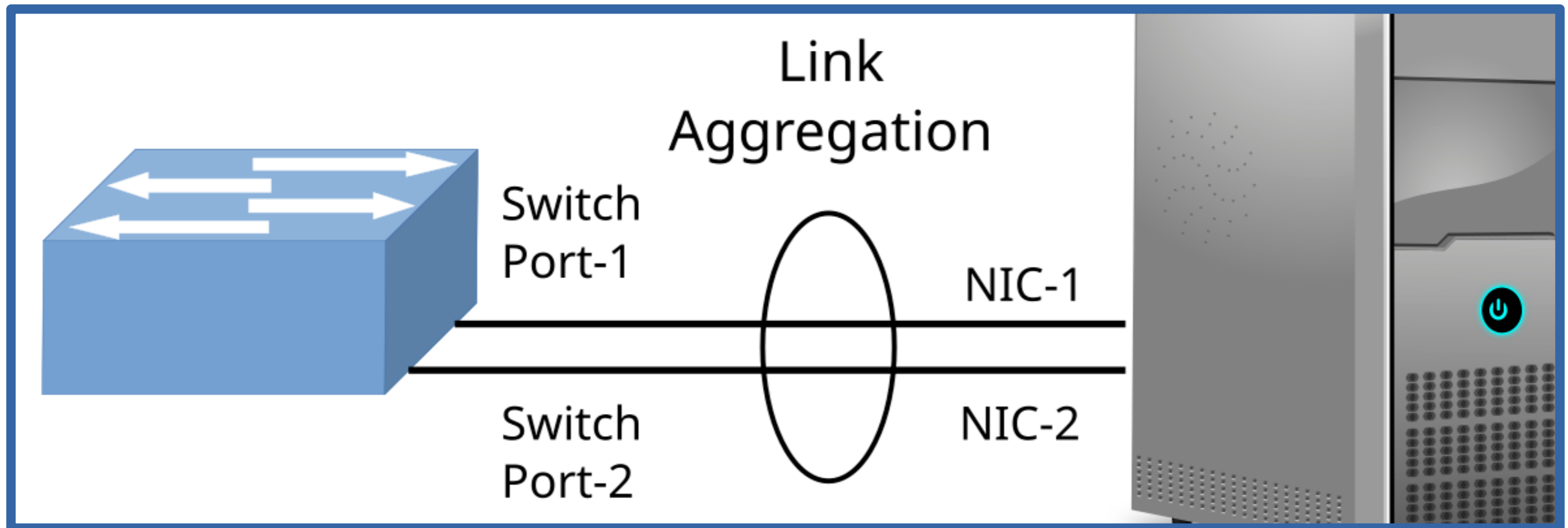
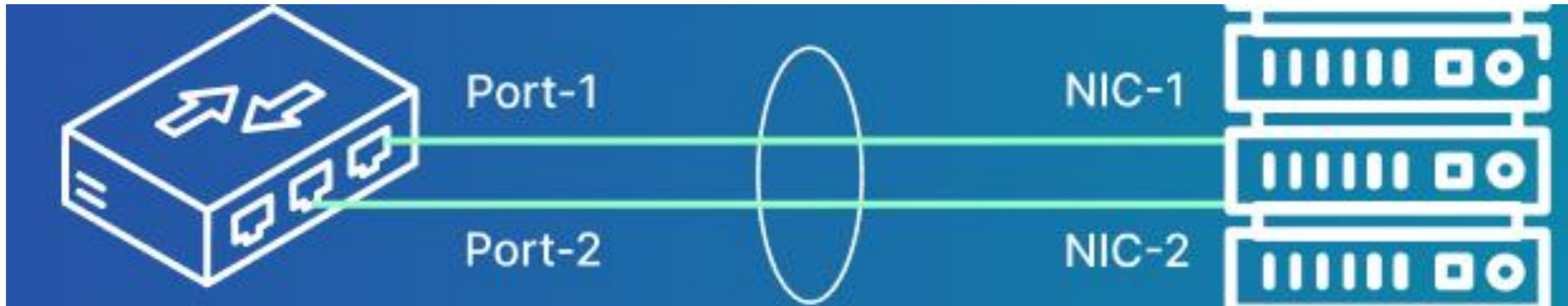

- Attenuation: signal degradation over distance and time

Optical Signal Attenuation

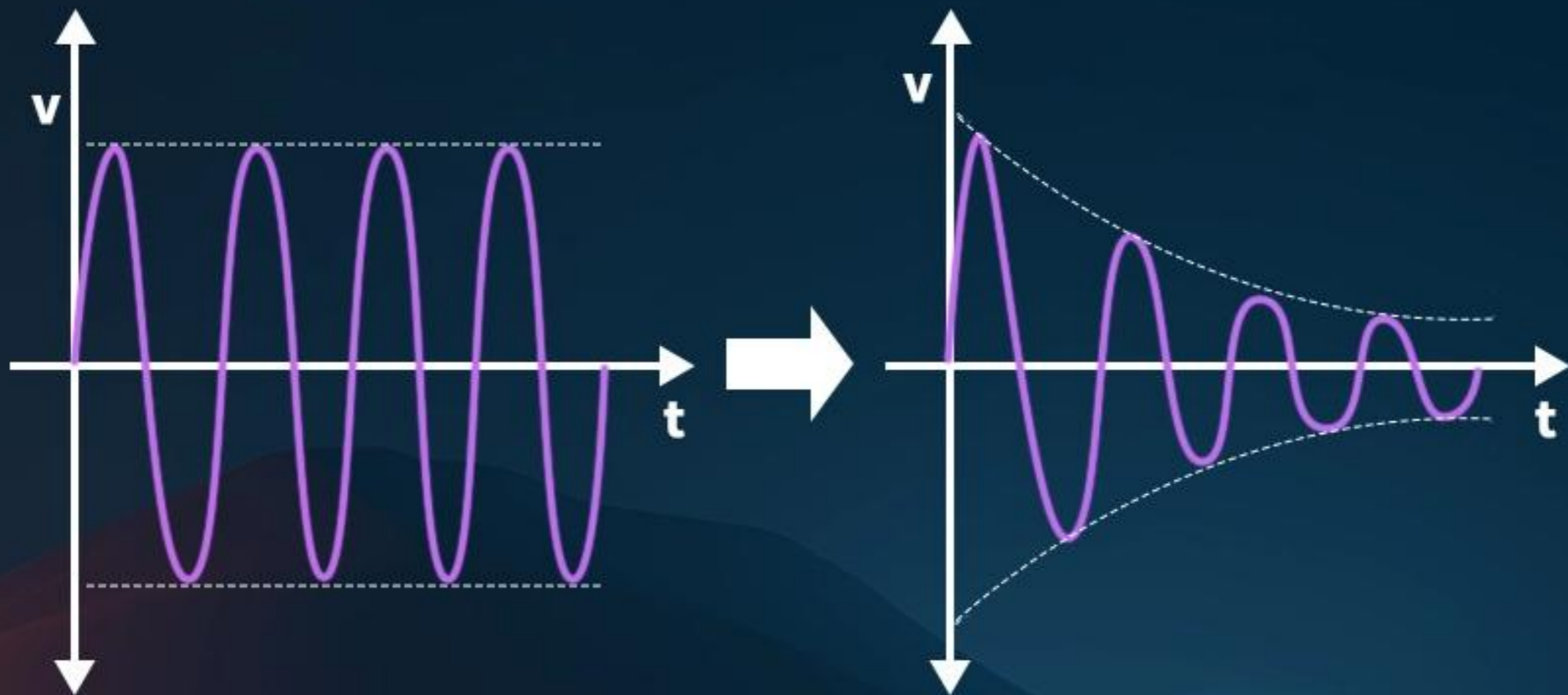

- Amplifiers adds power and amplitude to attenuated signal
- Also amplifies noise over time

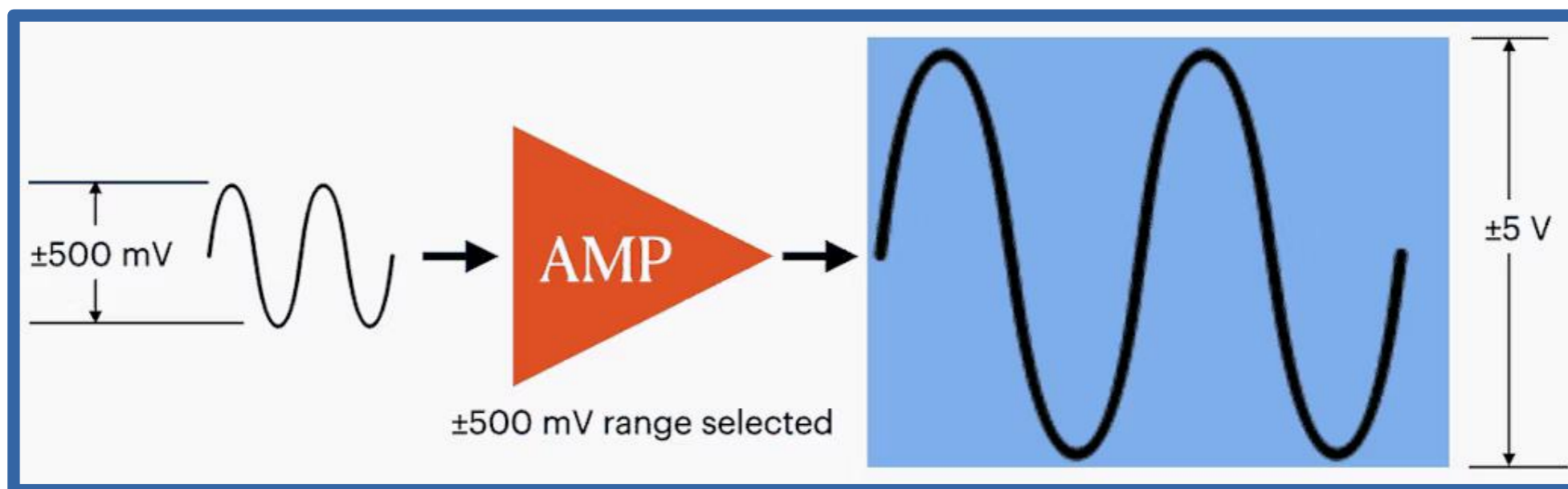
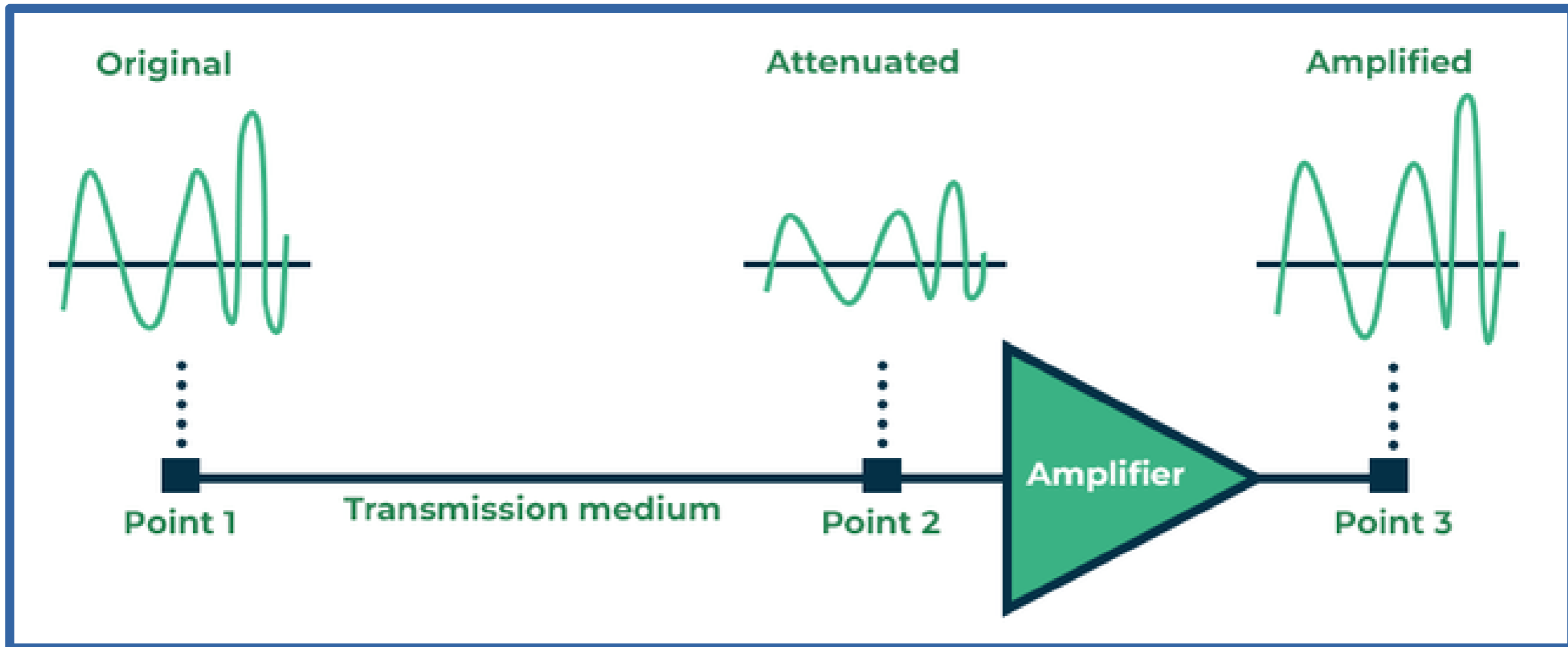

- Cleaning analog signal is difficult
- Cannot tell if static is part of the signal

2-seconds 2 Hz signal

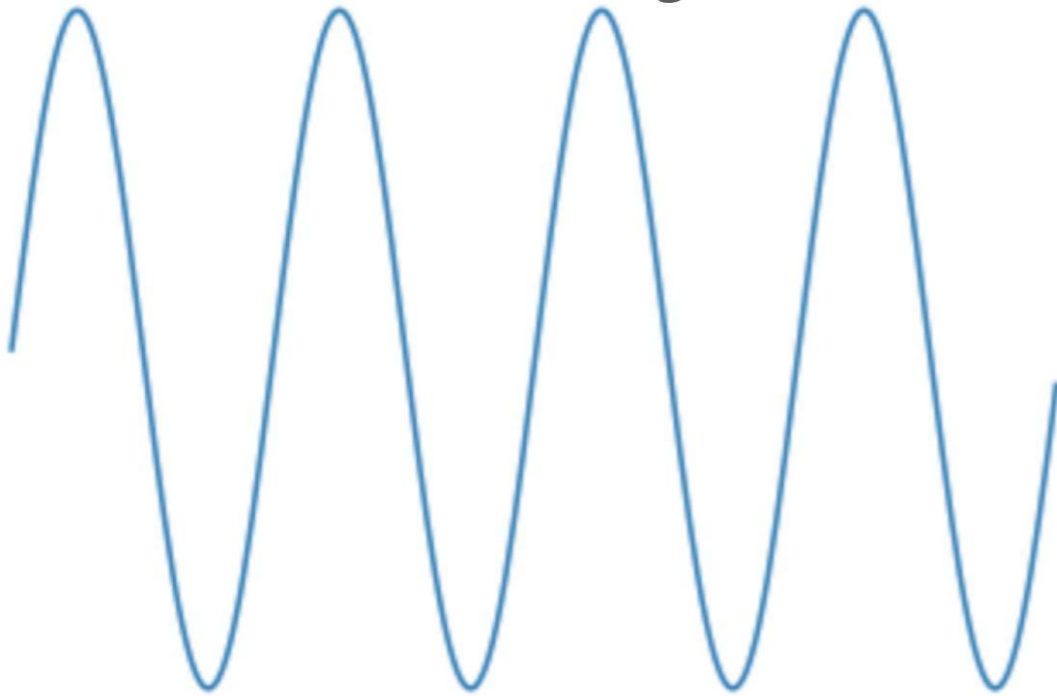

Added a little noise

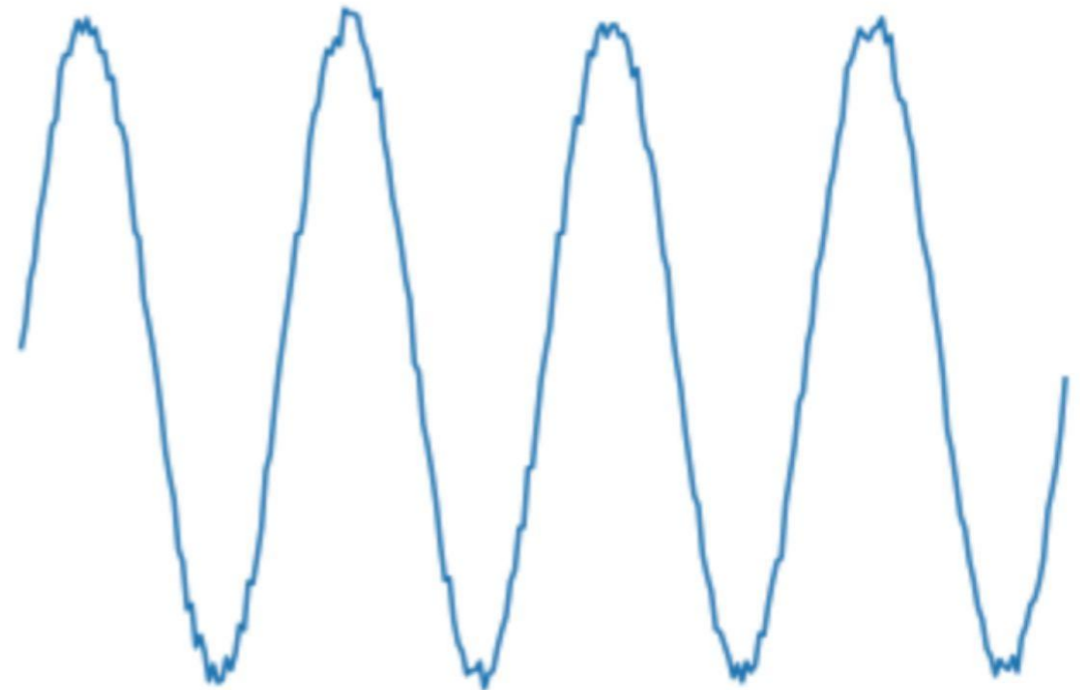

Some more noise

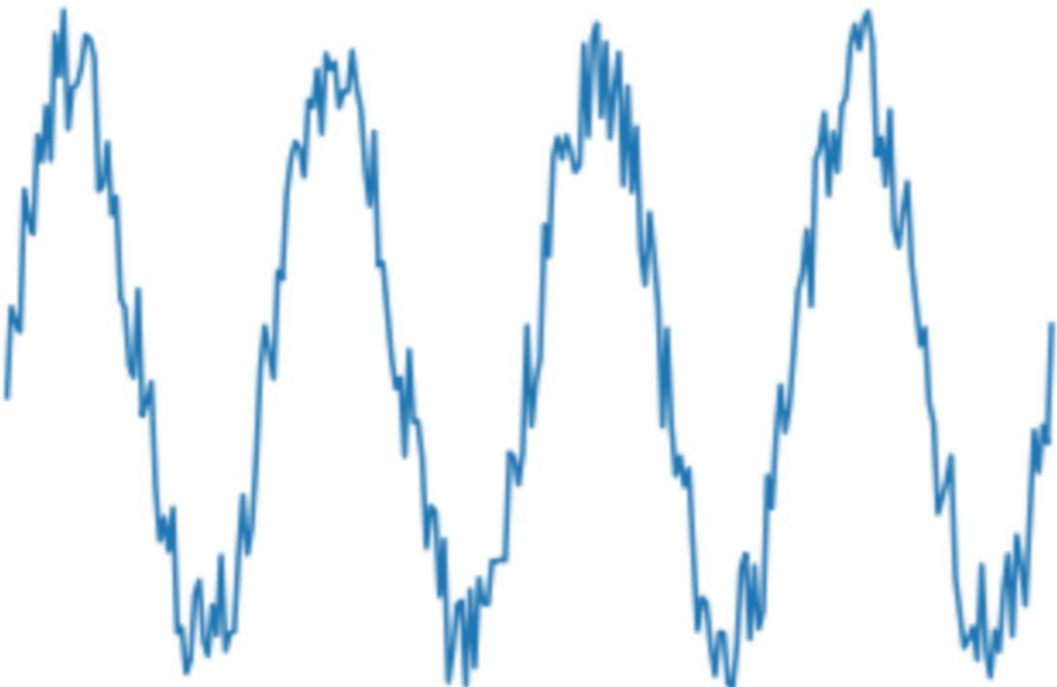

Even more noise

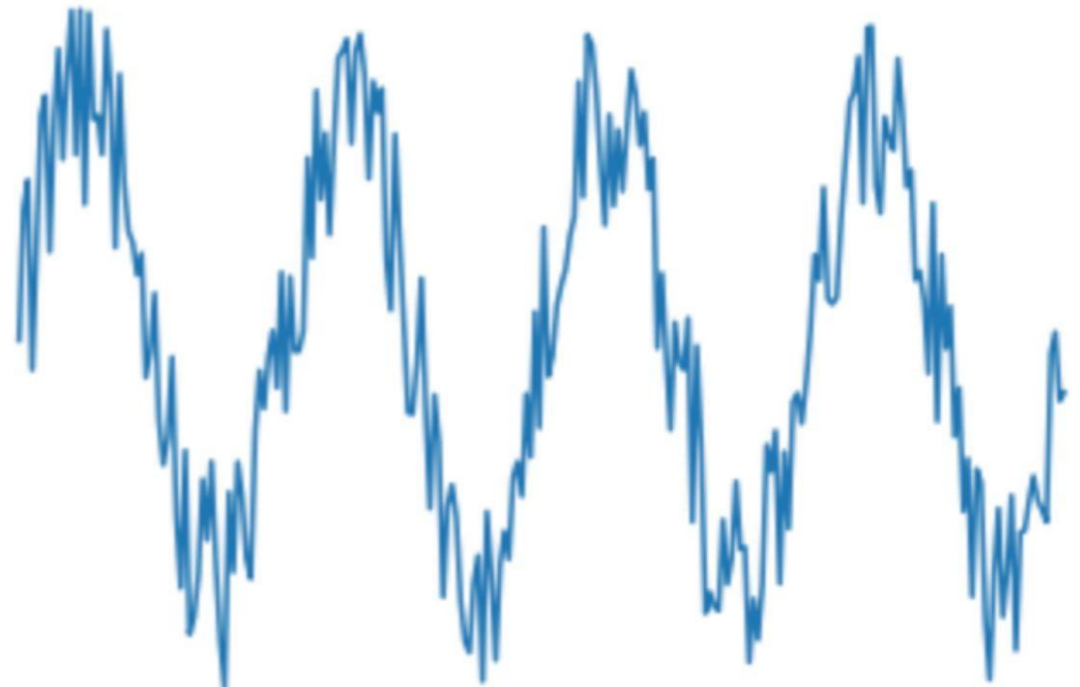

- Digital signal can be cleaned
- Know if it is 0 or 1; parity and patterns

Signals and noise

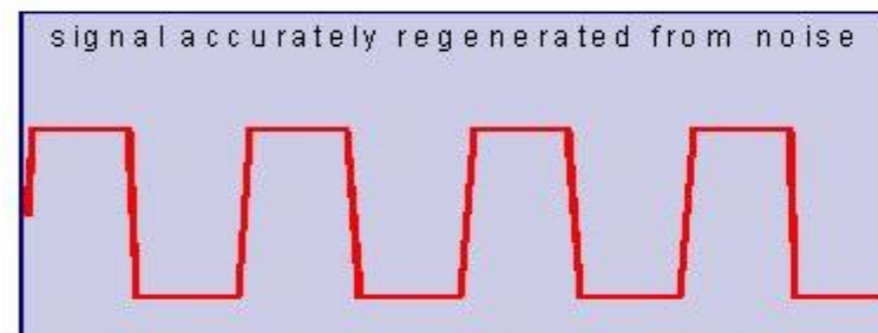
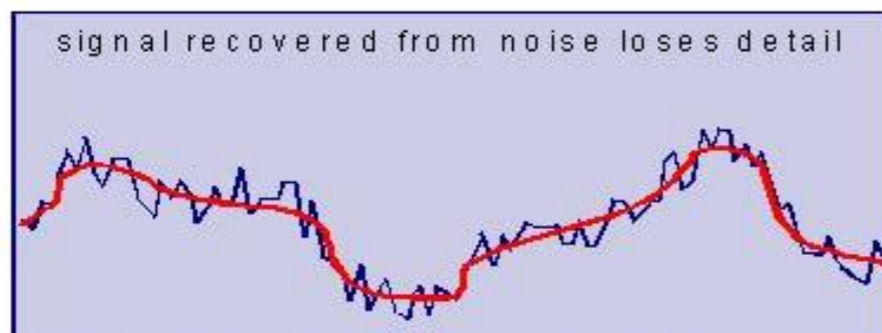
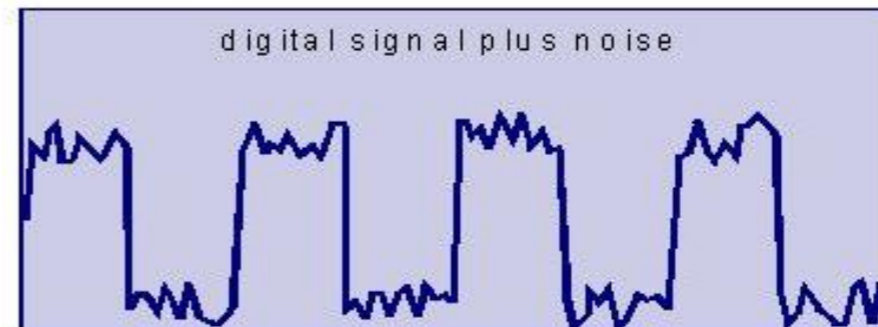
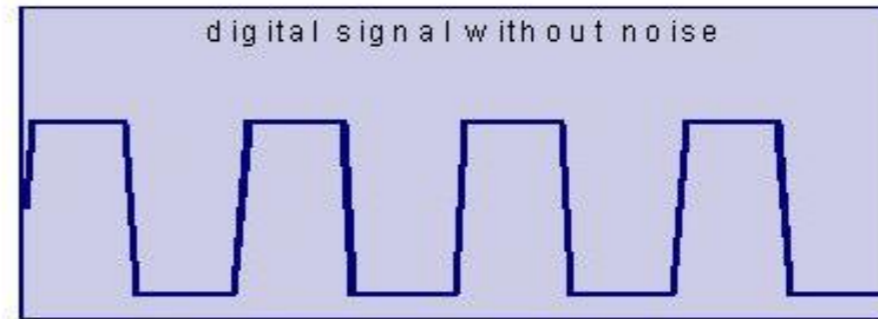
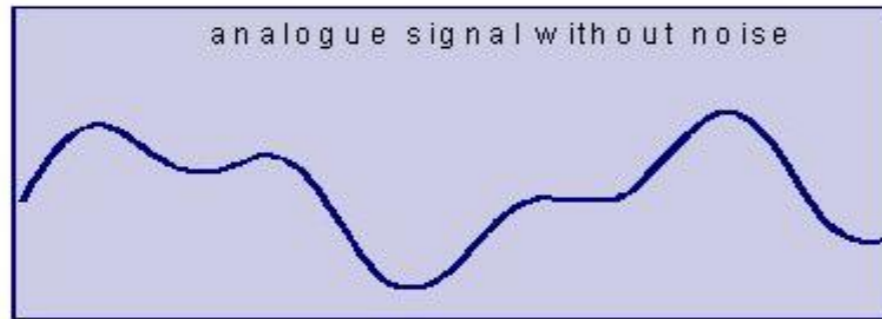

Analogue signals are spoilt by noise

Digital signals resist effects of noise

- Repeaters boost signal that has been attenuated; Ethernet 100 m limit

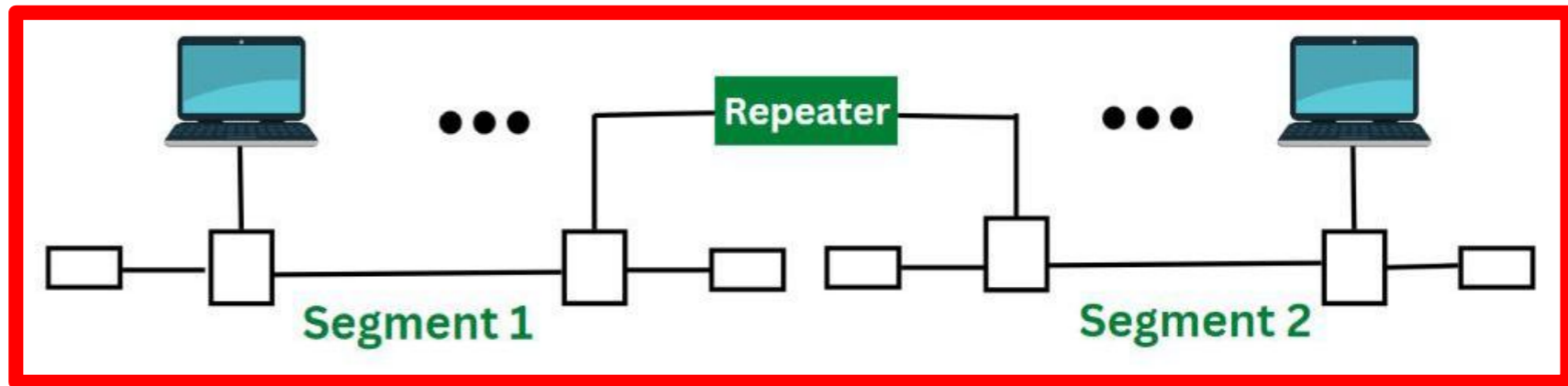
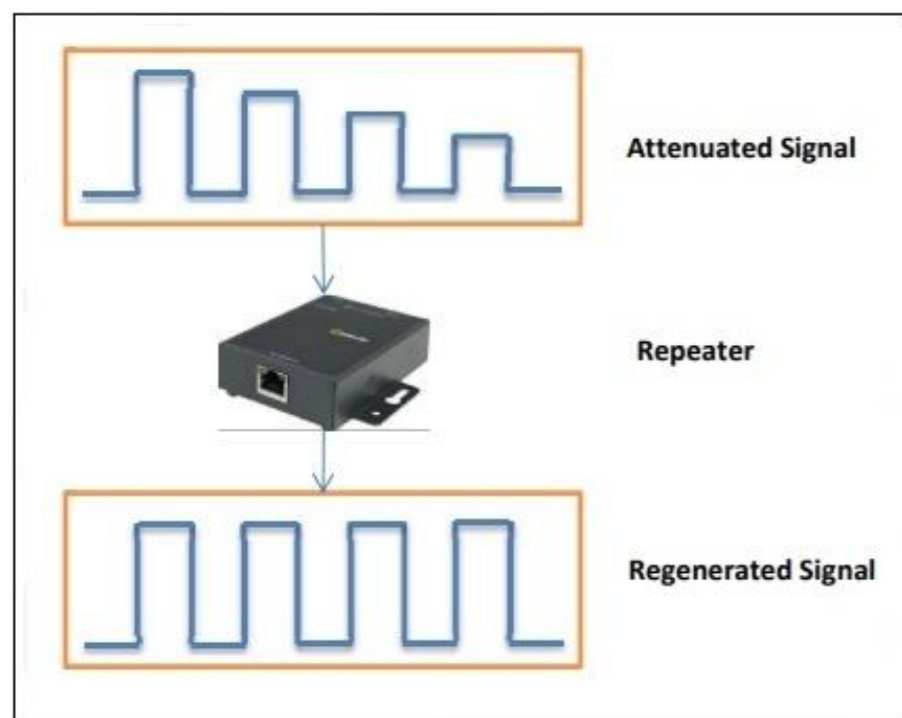
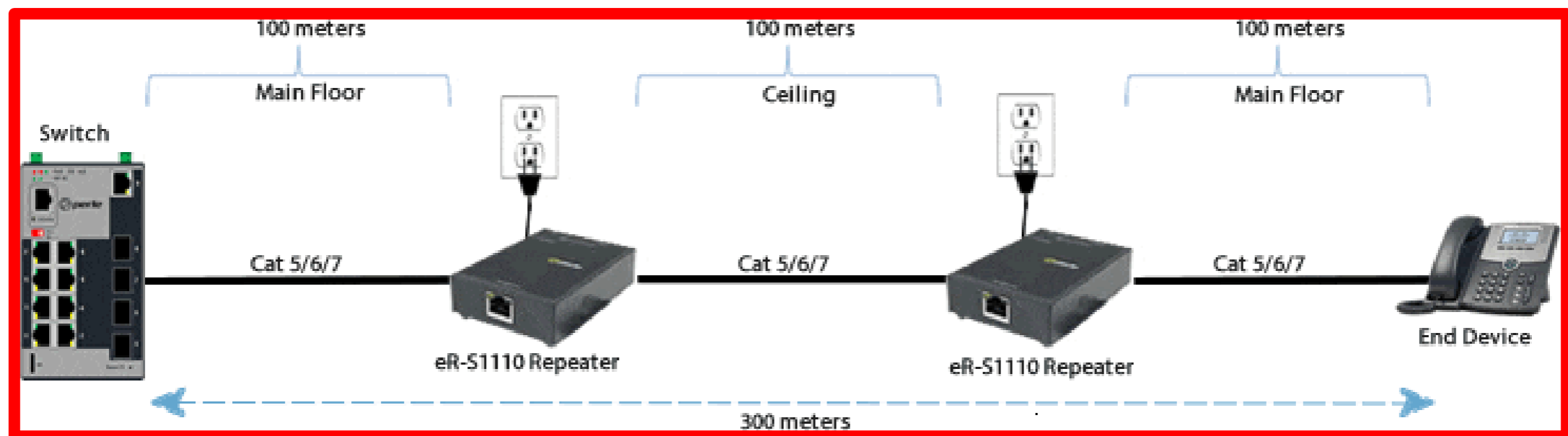
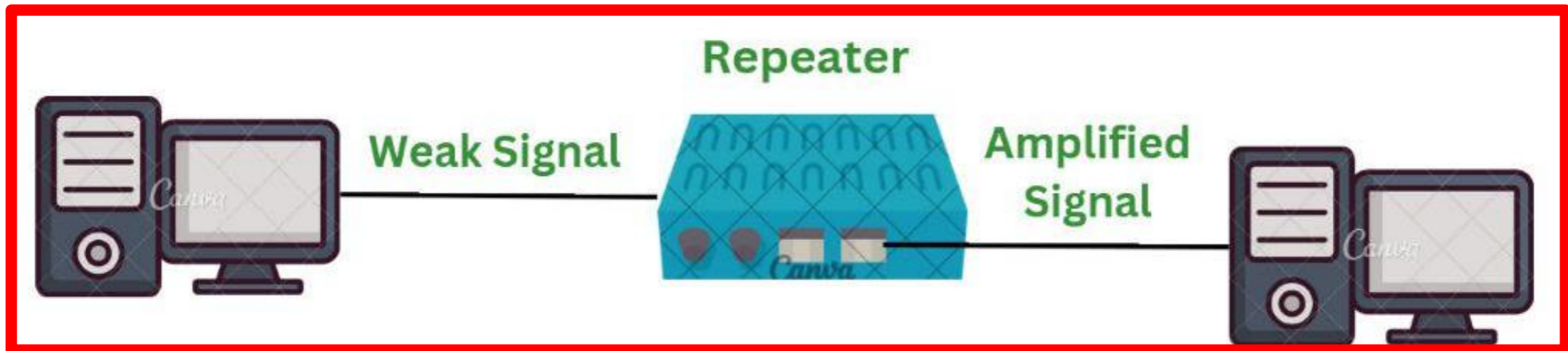

- Hub: broadcasts out to everyone; not intelligent

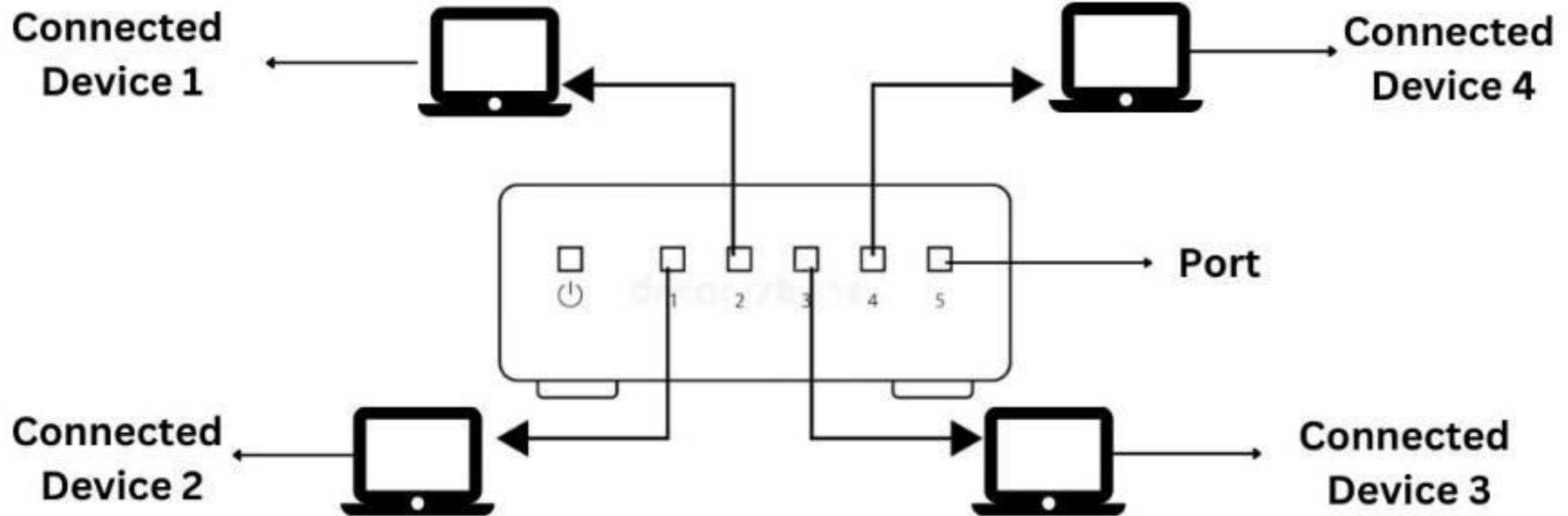
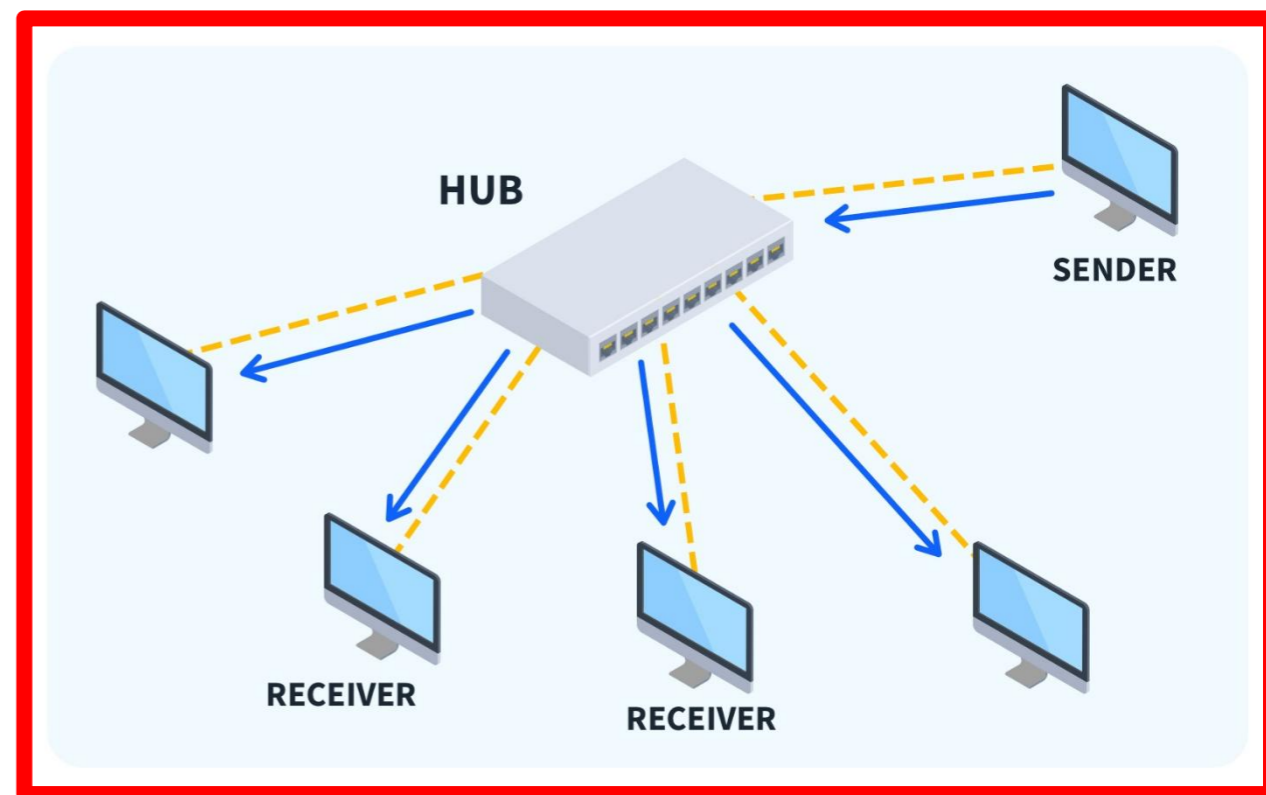
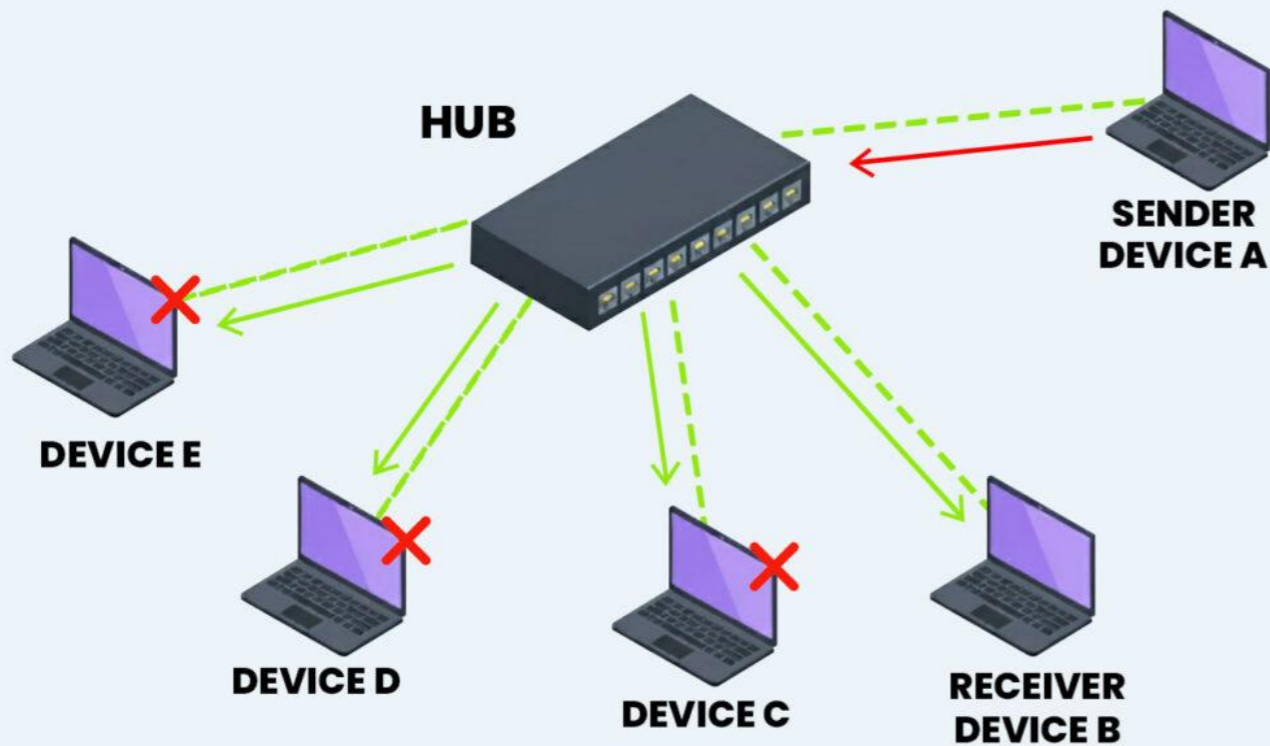

- Switch: learns connections by port; more intelligent than hub
 - Learns MAC addresses & guides signal to the right port

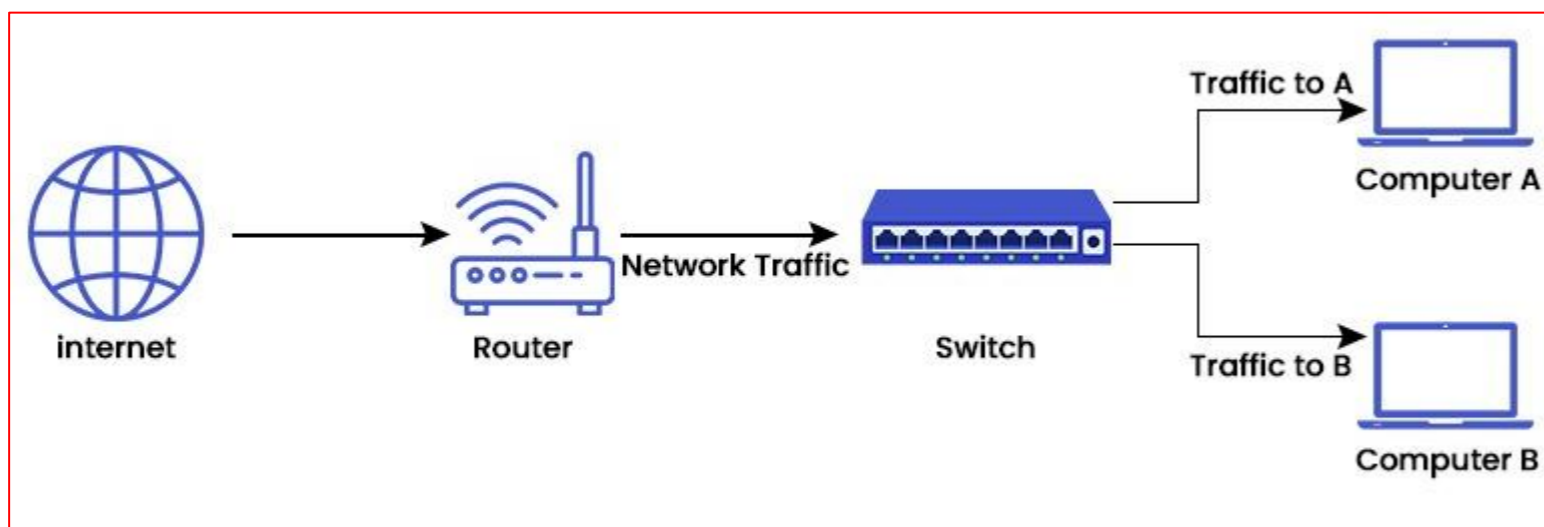
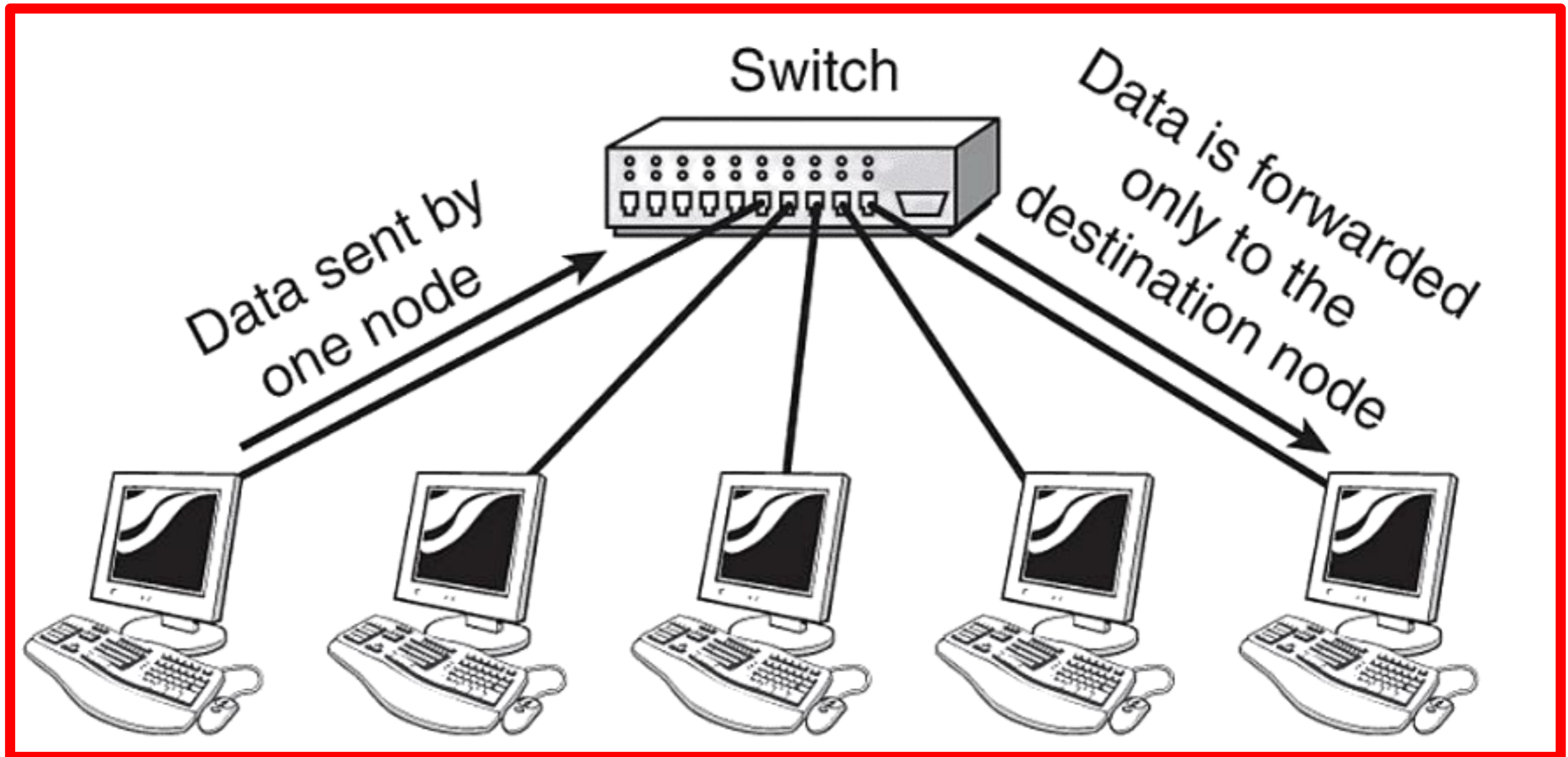

- Each switch maintains a Port Table based on MAC address
- Switches are hierarchal
- Tables rebuild in seconds

Spanning Tree Protocol

- Multiple links to same location
- One link goes down, will activate redundant line

A Living Architecture: How STP Adapts to Change

The Spanning Tree topology is not static. It automatically re-calculates to maintain connectivity when the network changes.

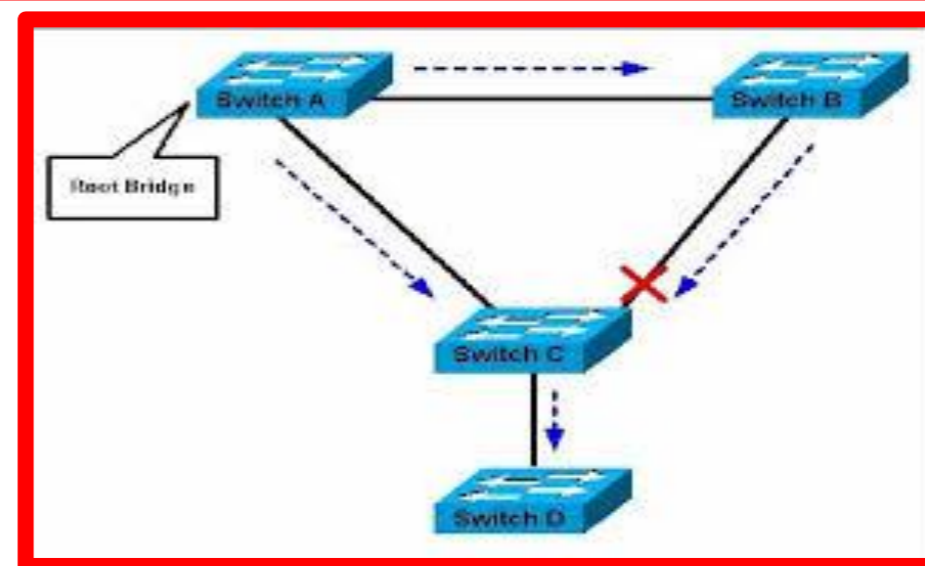
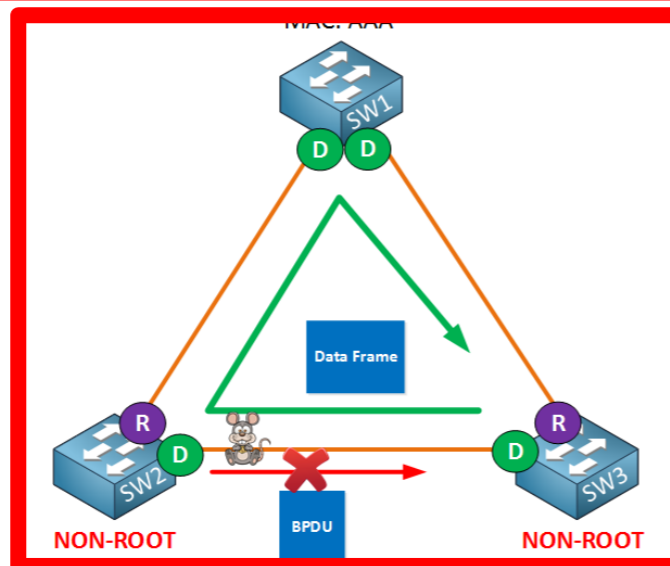
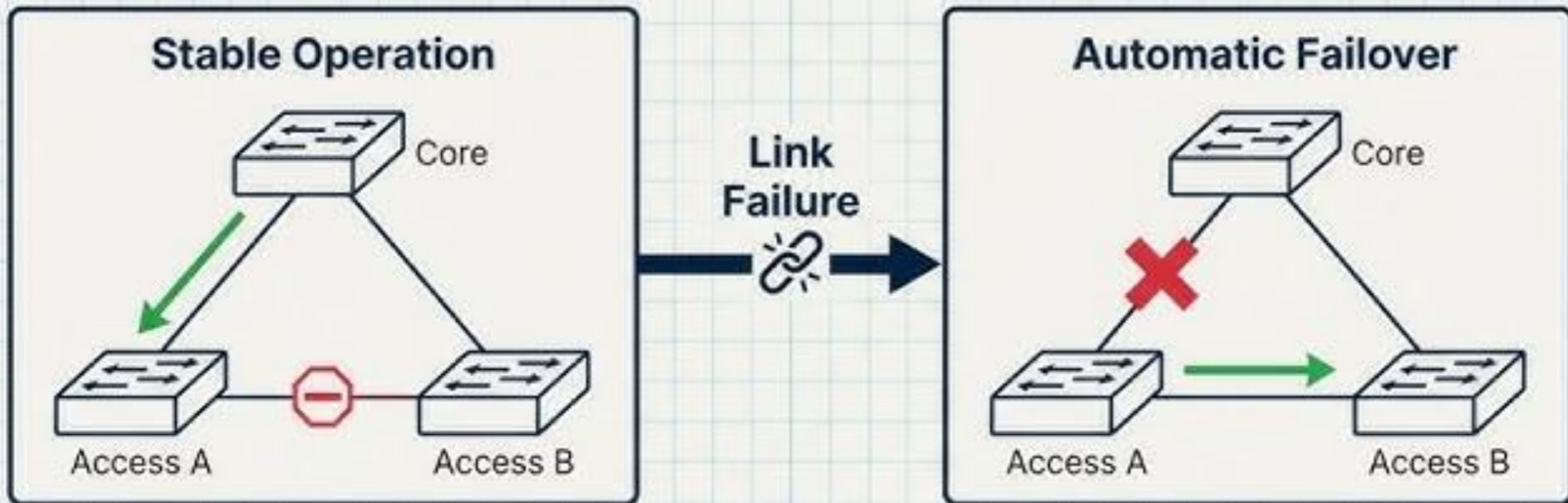

VLAN: Virtual Local Area Network

- Instead of having 1 switch for each department, use 1 switch for 2 depts

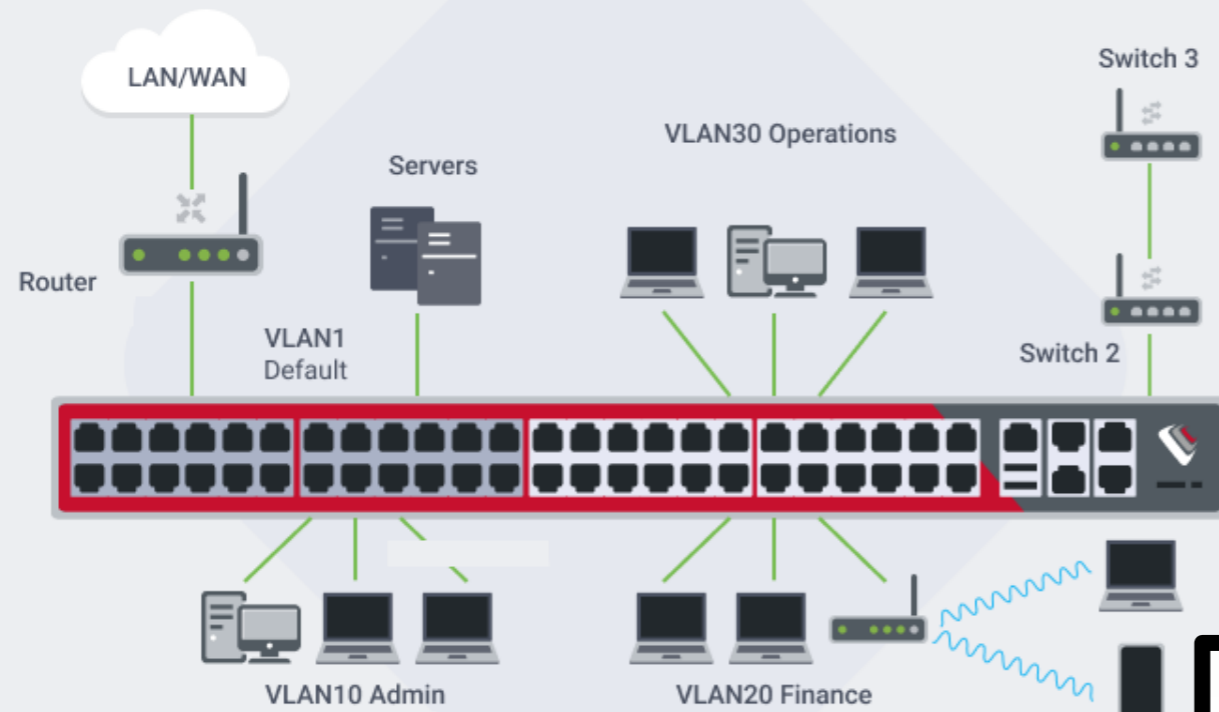

- VLANs provide better performance
- Higher security
- 1 switch treated as 2 switches



VLAN (Virtual Local Area Network) in a Switch



Port-Based Authentication [802.1X]

- Authenticates credentials with server
- If fails, the port on switch is turned off/disabled

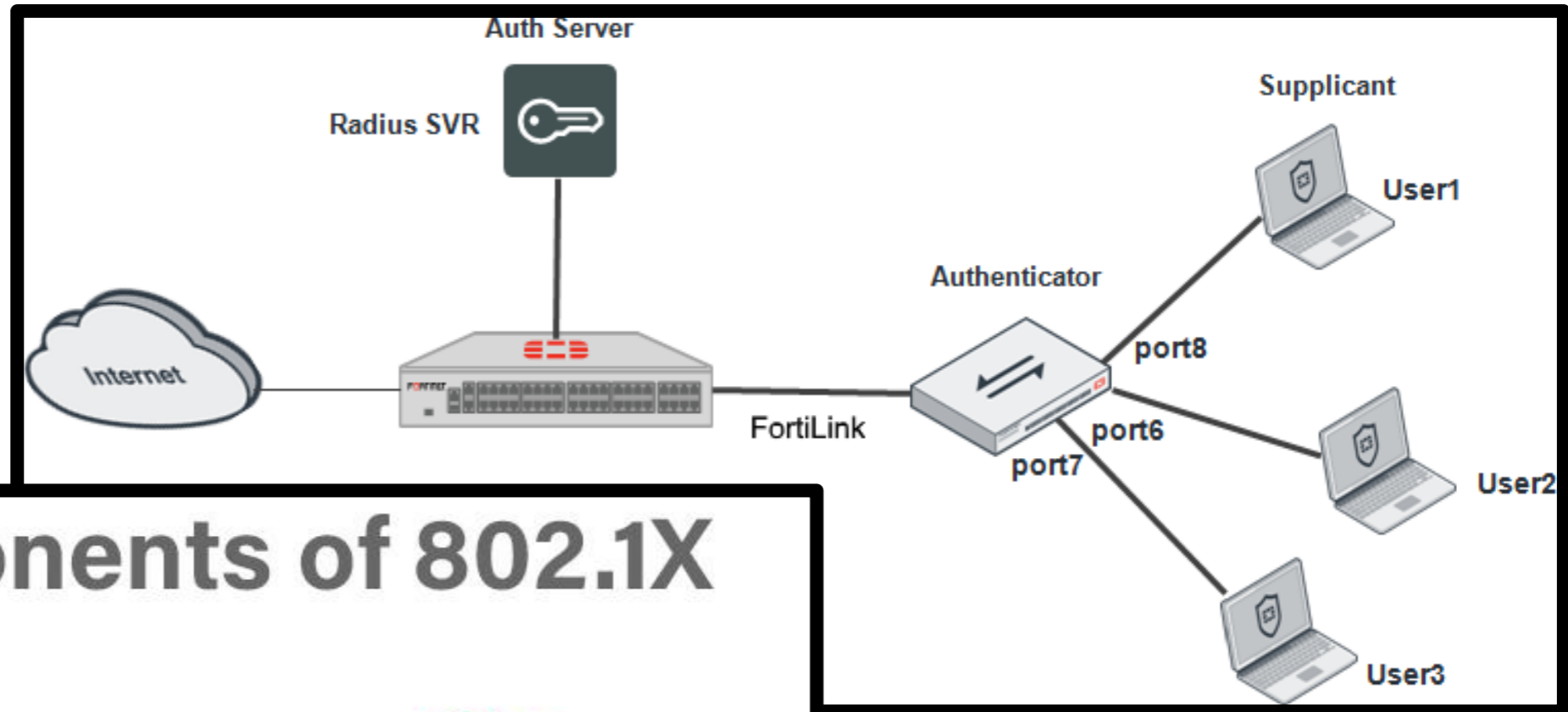

The components of 802.1X

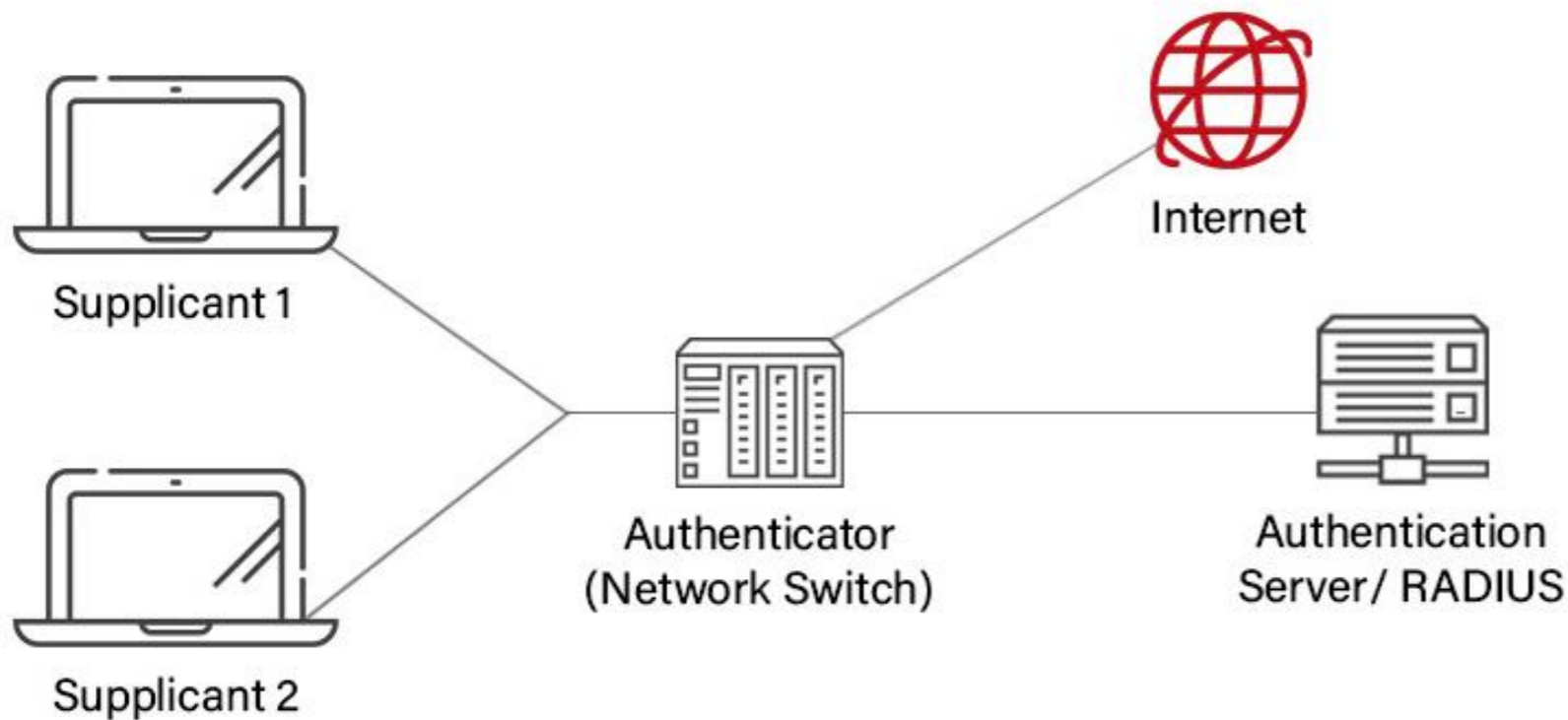

Wireless LAN [802.11] aka Wifi

- Ubiquitous; connected all the time
- Information is encrypted across wireless connection
- Operates on Level 2

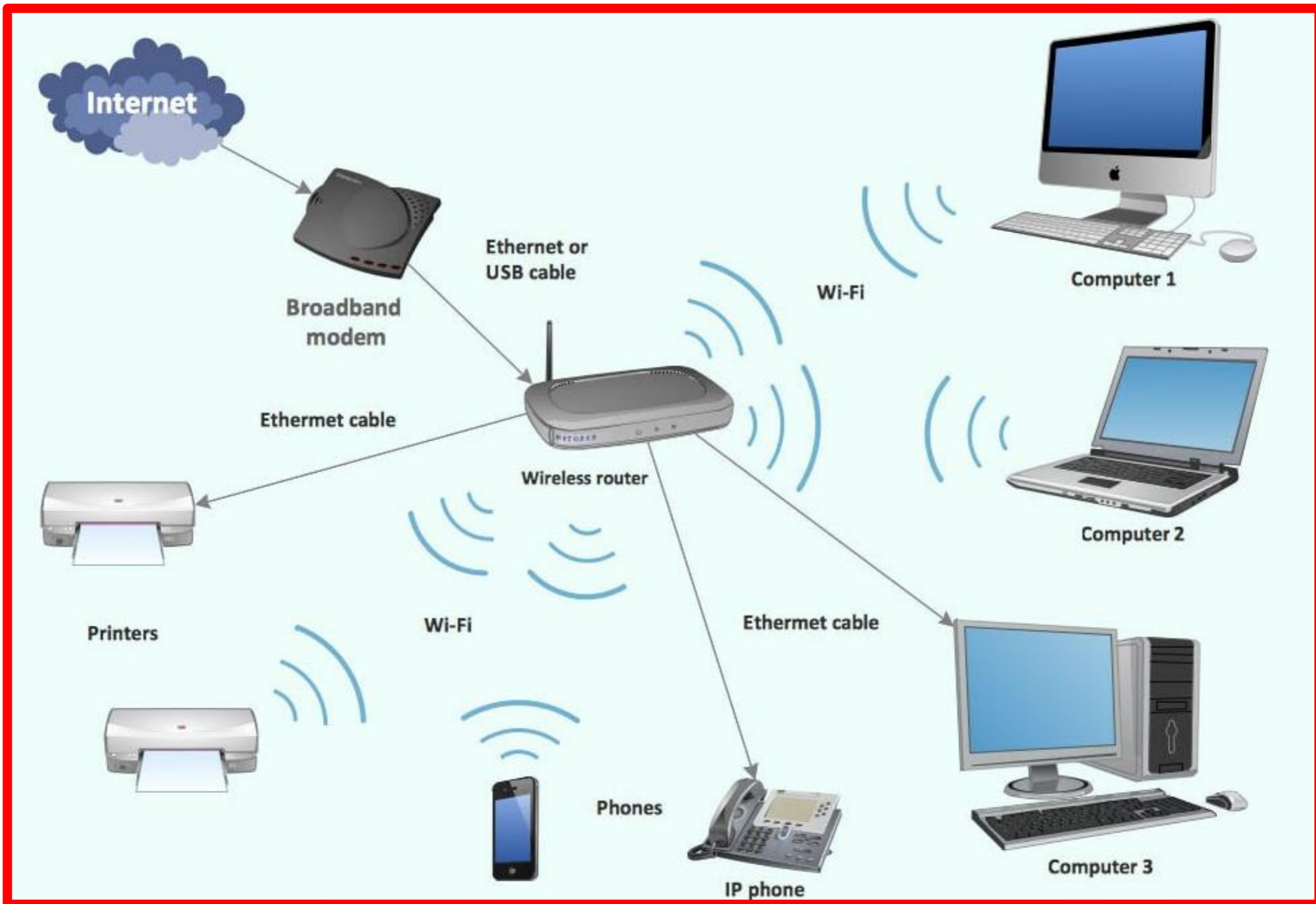

Wireless Access Point is the heart of Wifi network

- Connects to wired network
- Wireless laptops connect to each other through the Access Point

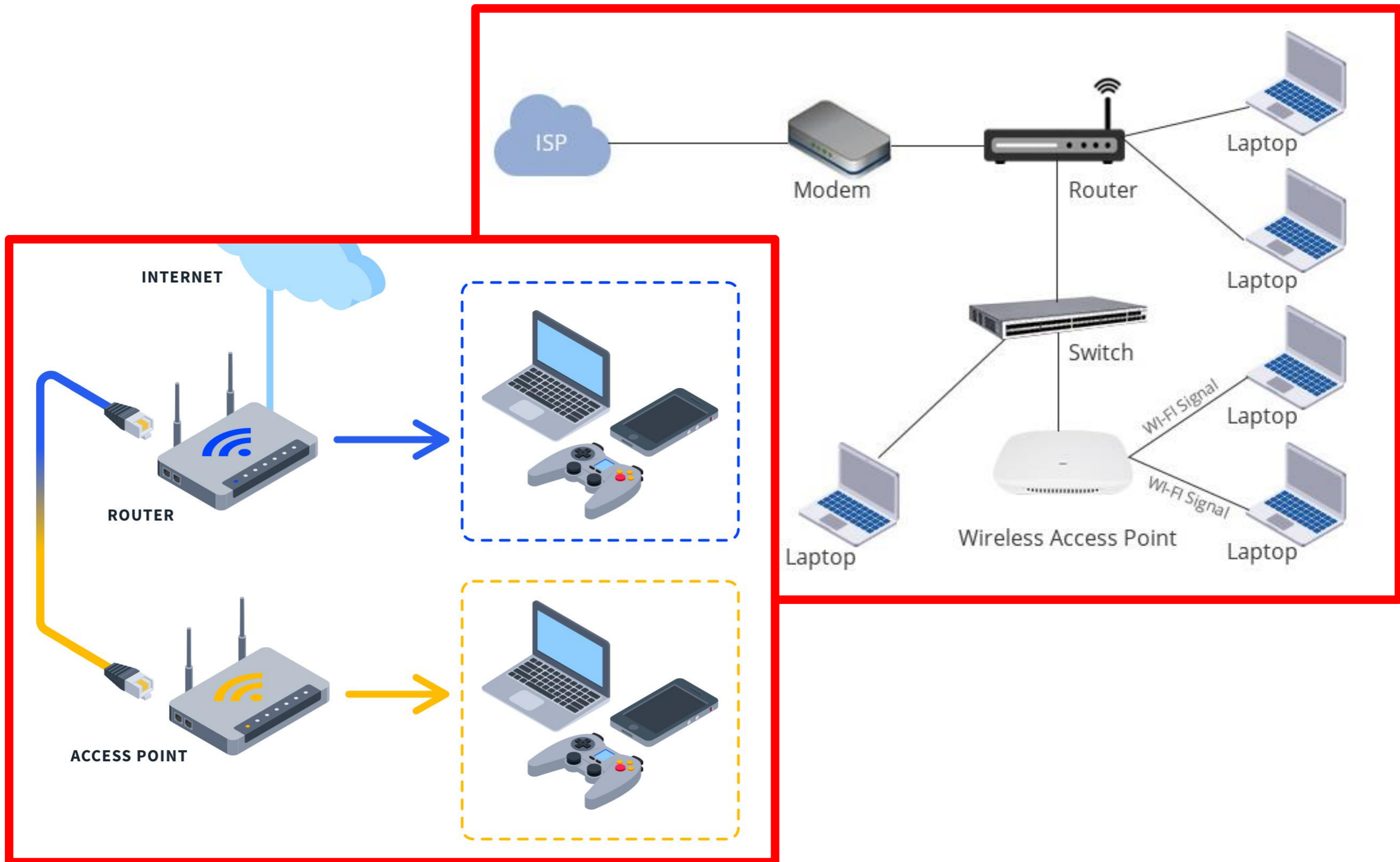

Encapsulation in action
- 802.11 > Layer 2 protocol

Wireless to Wired encapsulation



802.11 Wireless Frame

Sent to Access Point

Access Point receives frame

Access Point converts frame to 802.3 wired frame

Wired to Wireless encapsulation



802.3 Wired Frame

Sent to Access Point

Access Point receives frame

Access Point converts frame to 802.11 wireless frame

Wireless Frame
(802.11)



Ethernet Frame

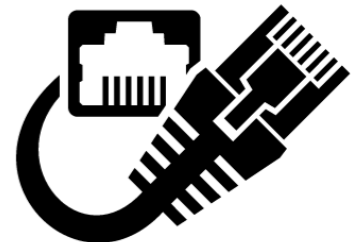

Antennas – 2 Types

- Omnidirectional: broadcasts in all directions
- Directional: narrow stream of data; aimed at satellites

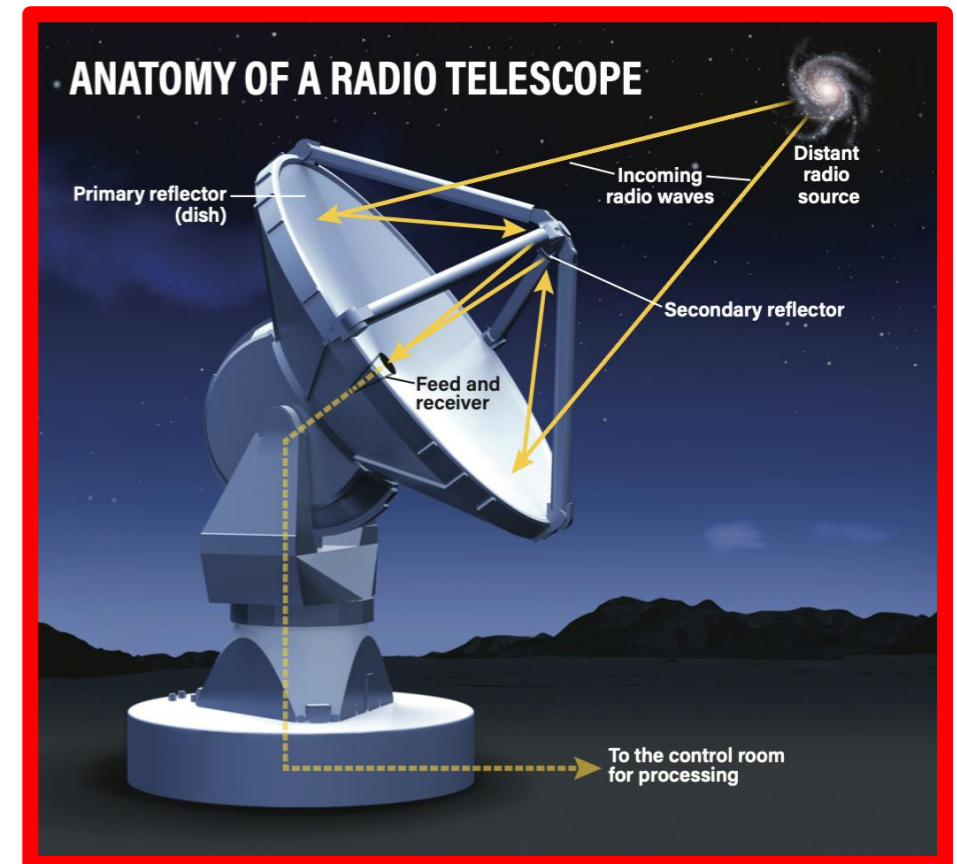
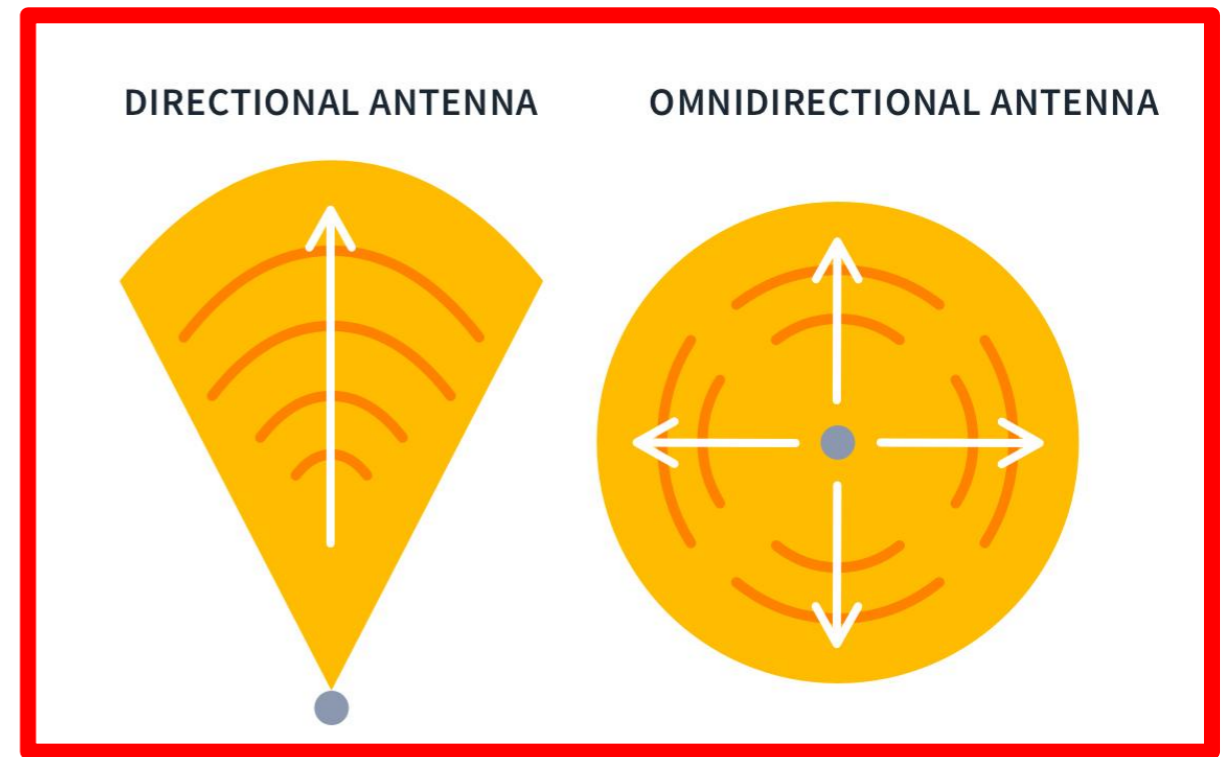
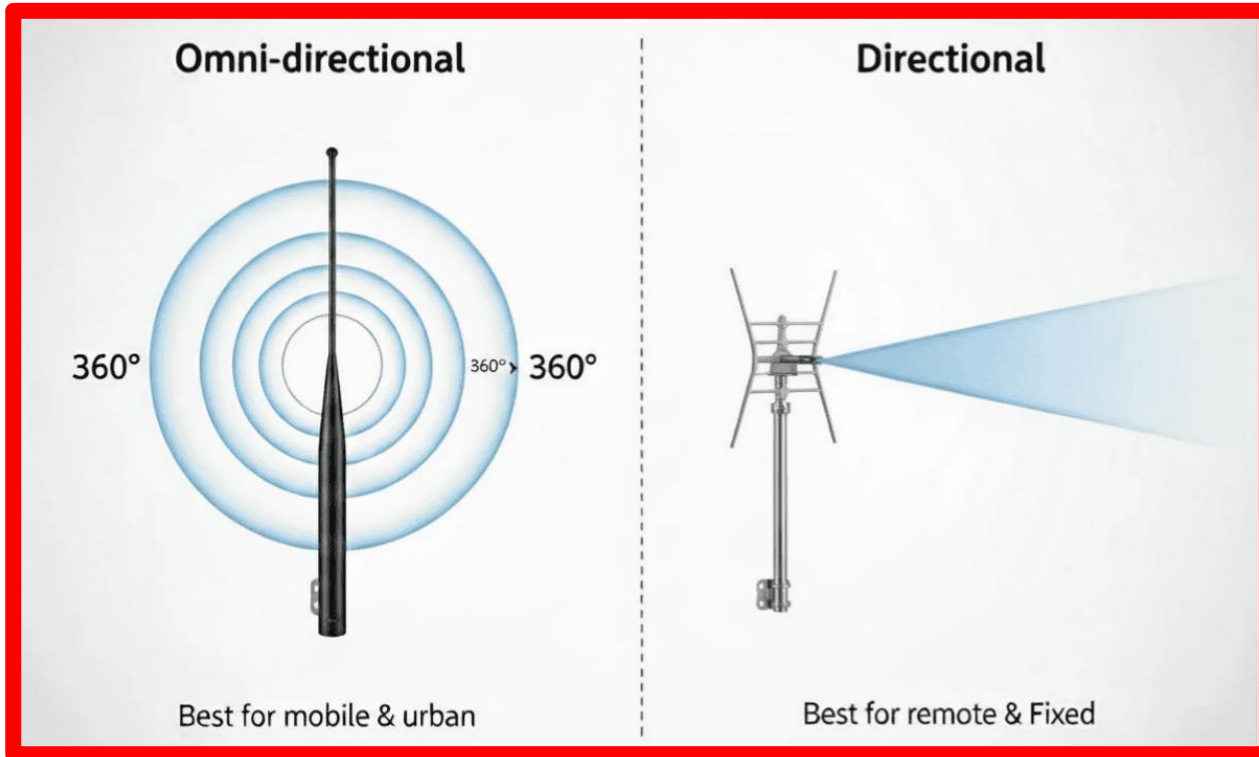

Cantenna

- Do It Yourself directional antenna



EMI – Electromagnetic Interference

- Wifi attenuates over distance & time
- Will get dead zones when hits certain objects
- Omnidirectional wave bounces off floor, ceiling, plants

Three scenarios for Wi-Fi interference



Co-channel
Every client and access point on the same channel competes for time to talk

1



Adjacent-channel
Every client and access point on overlapping channels talk over each other

2

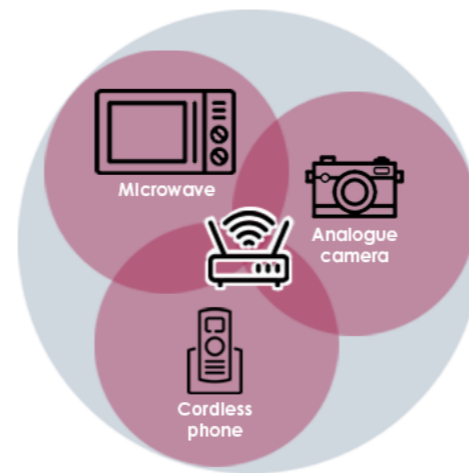

Non-WiFi
Household electrical devices (Non-802.11 devices) compete for medium access

3

EMI in our daily lives



Wi-Fi slowdown or dropouts



Buzzing or static in audio devices



Disrupted TV or radio signals



Dropped mobile calls



Smart home device issues



Interference with vehicle electronics