

• May 7 Notes

Frequency Spectrum Goes from zero to infinity

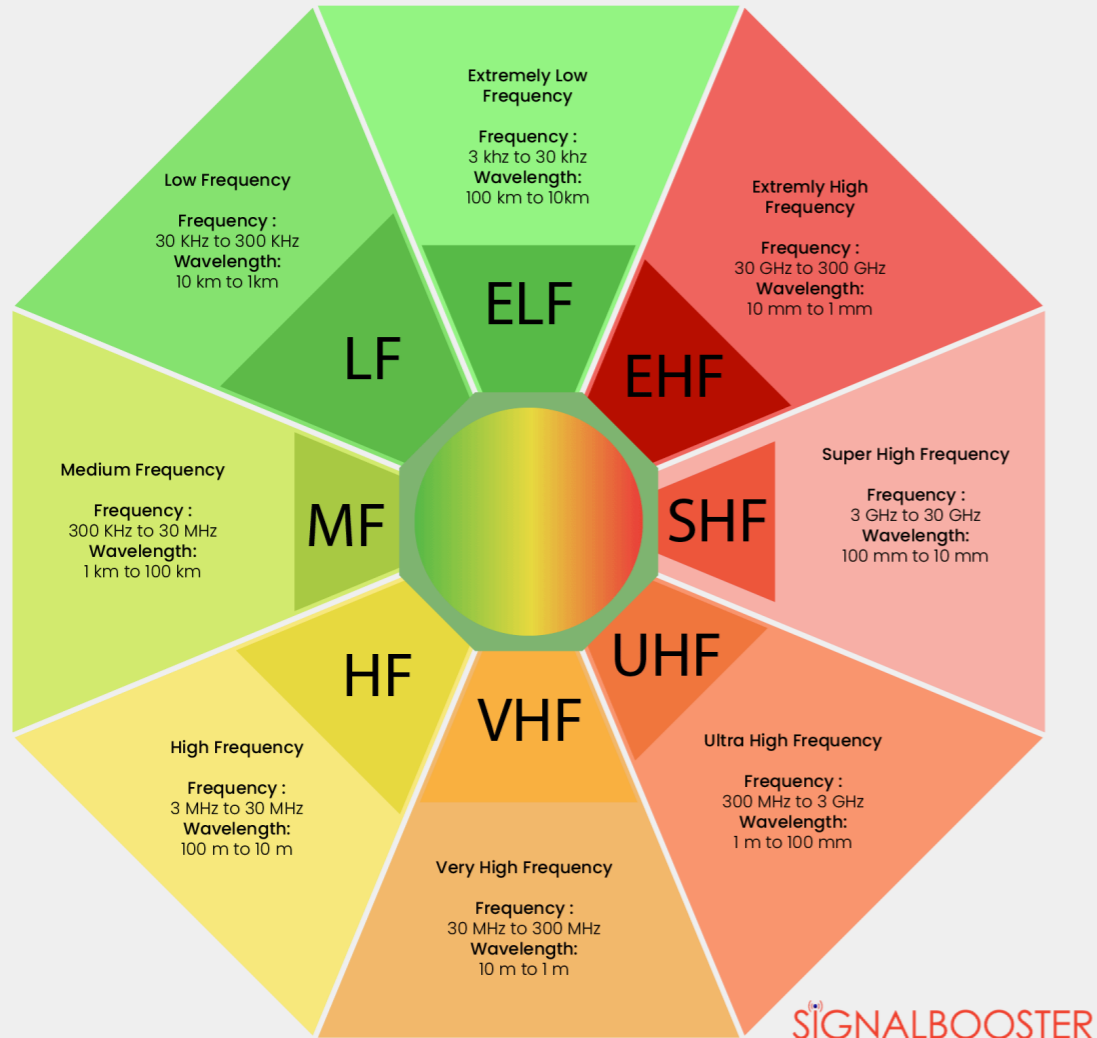

Radio Frequency Spectrums

SIGNALBOOSTER.COM

RADIO FREQUENCY BANDS & APPLICATIONS

RADIO FREQUENCY SPECTRUM

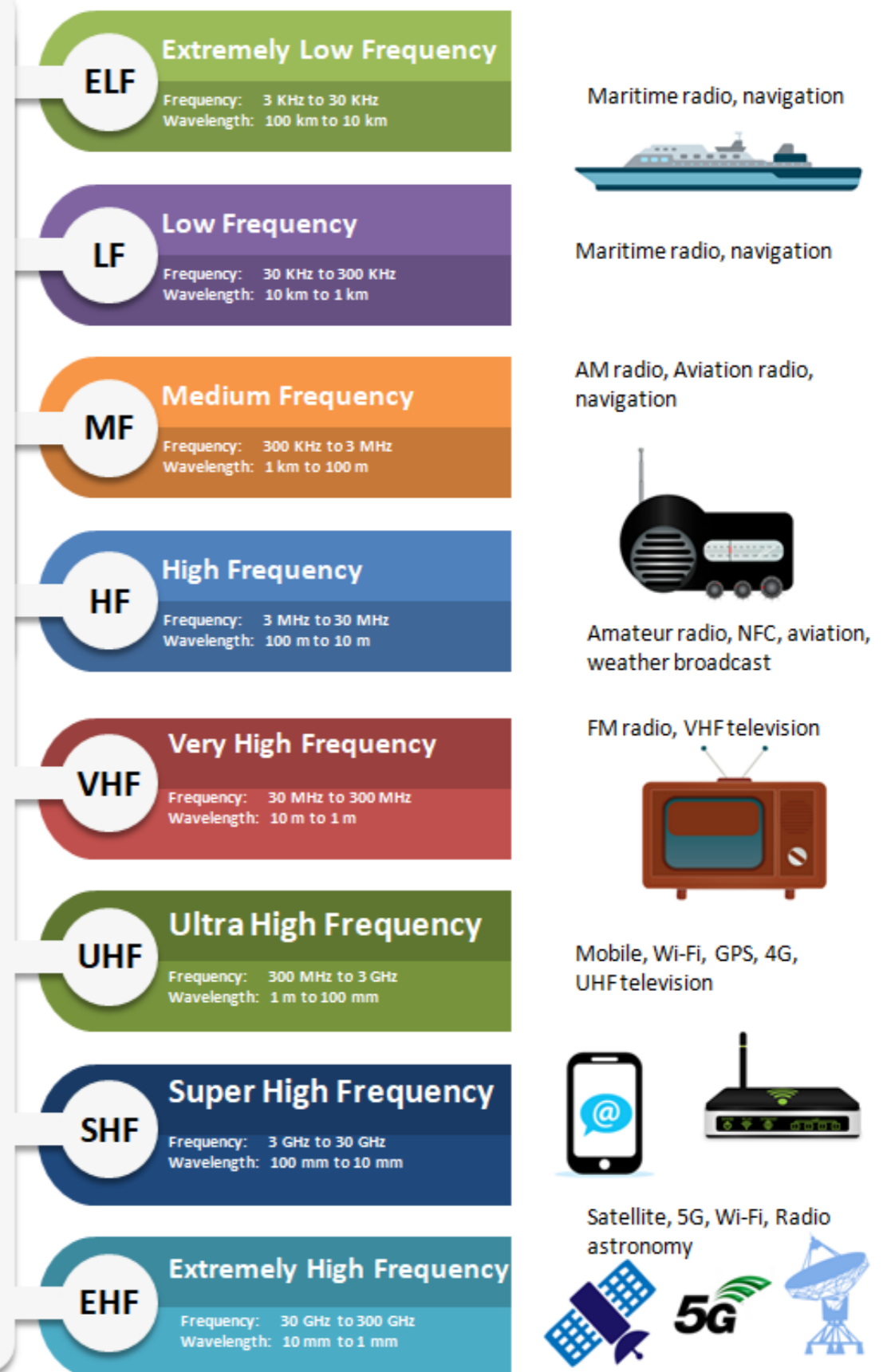

FM Radio : Broken into 100 channels of 200 khz each

AM Radio: Lower frequency but carries further in terms of distance

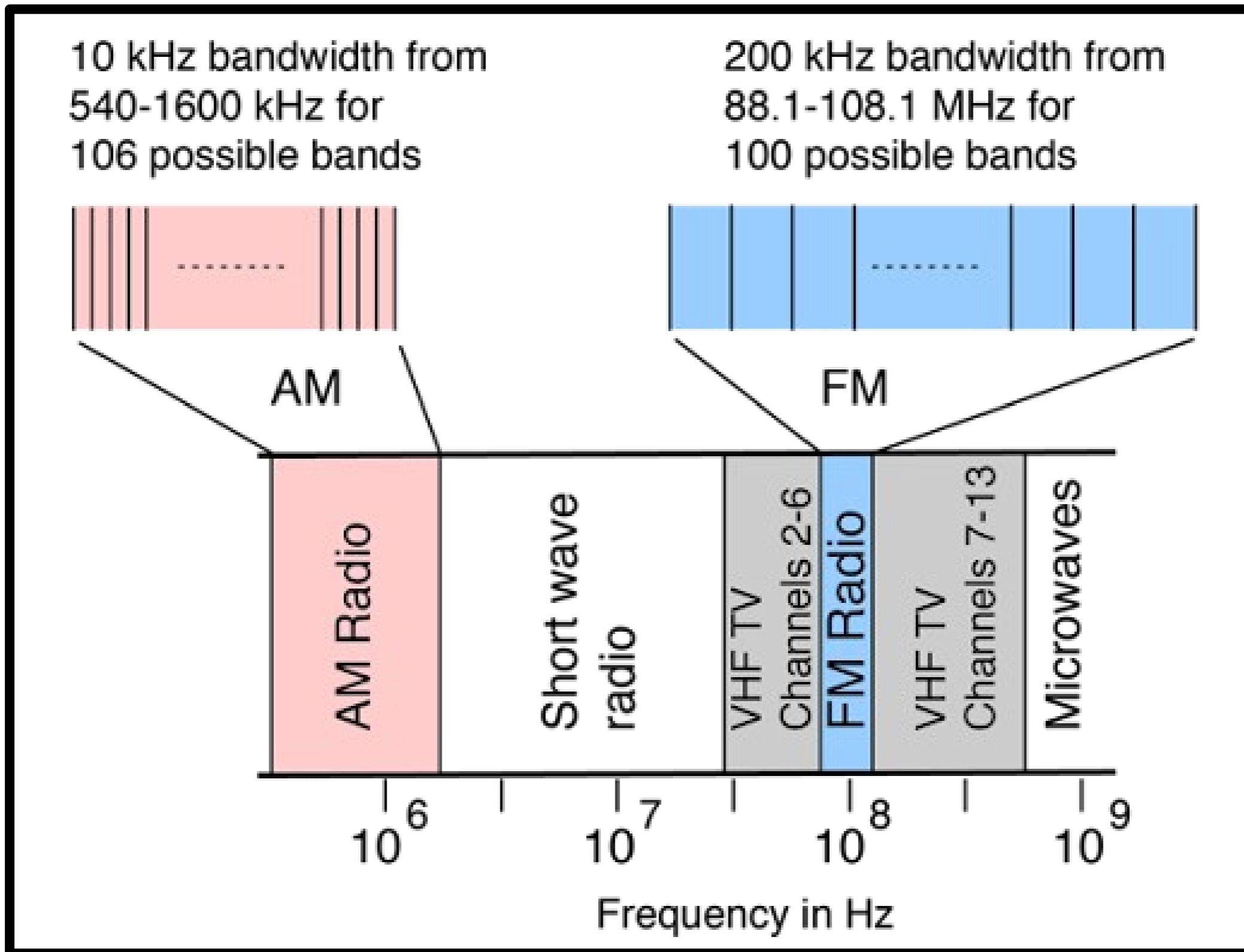

FM Radio

Split into channels of 200 khz each

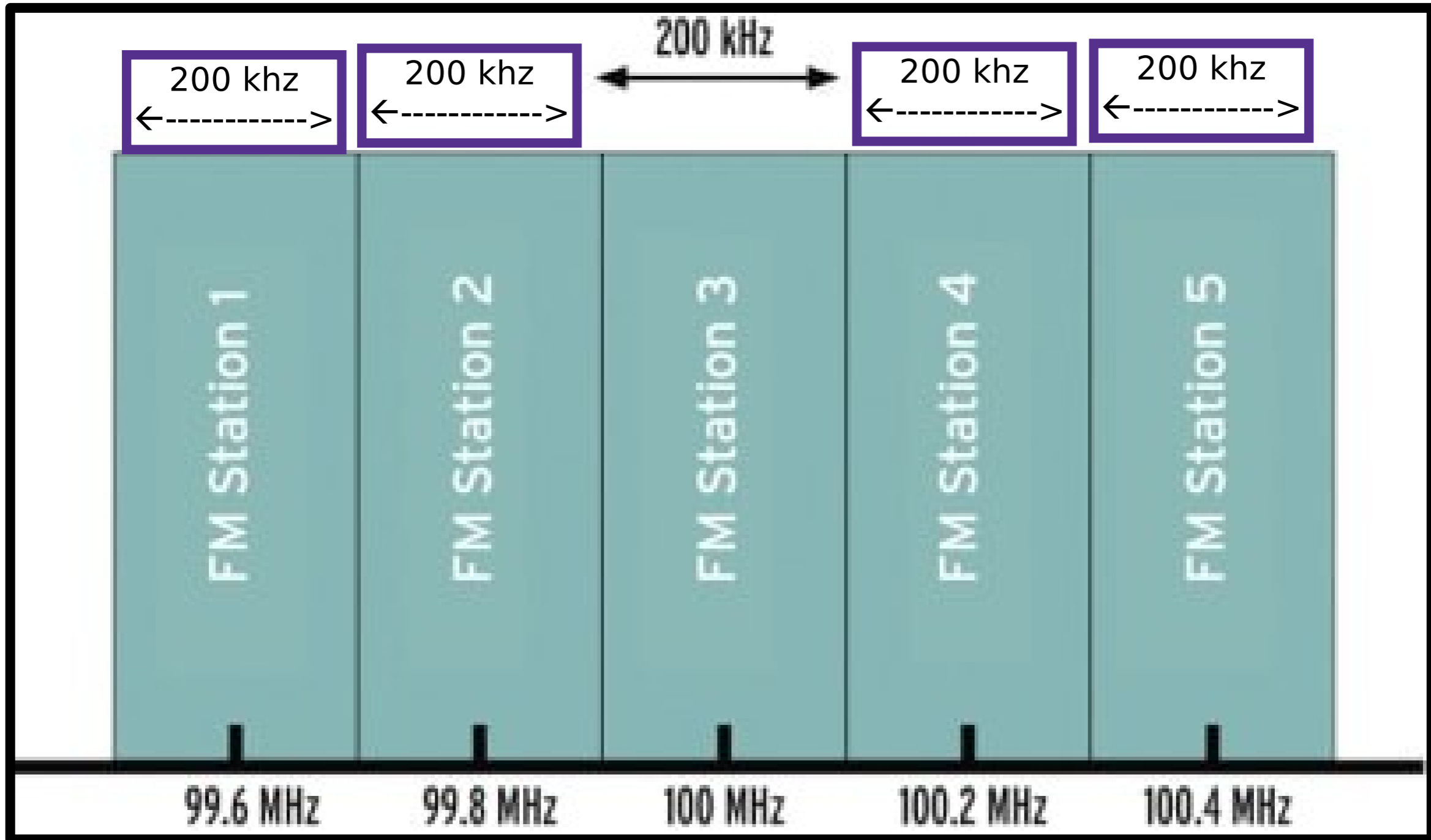

Wider channel has more information carrying capacity

5 cm Band Example Channel Widths

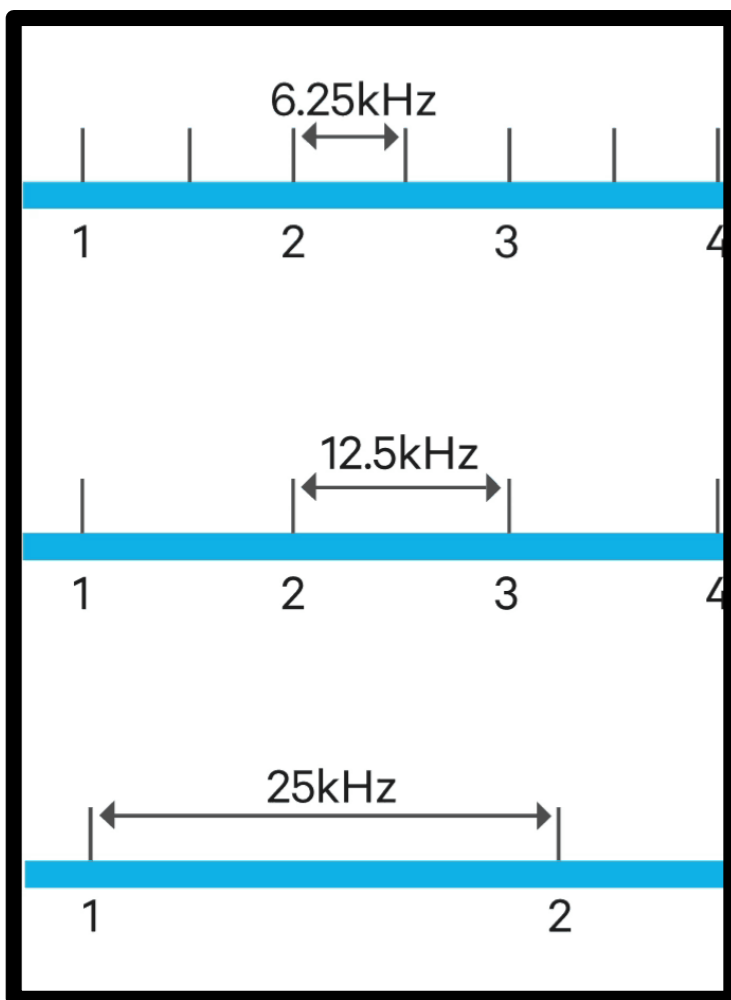
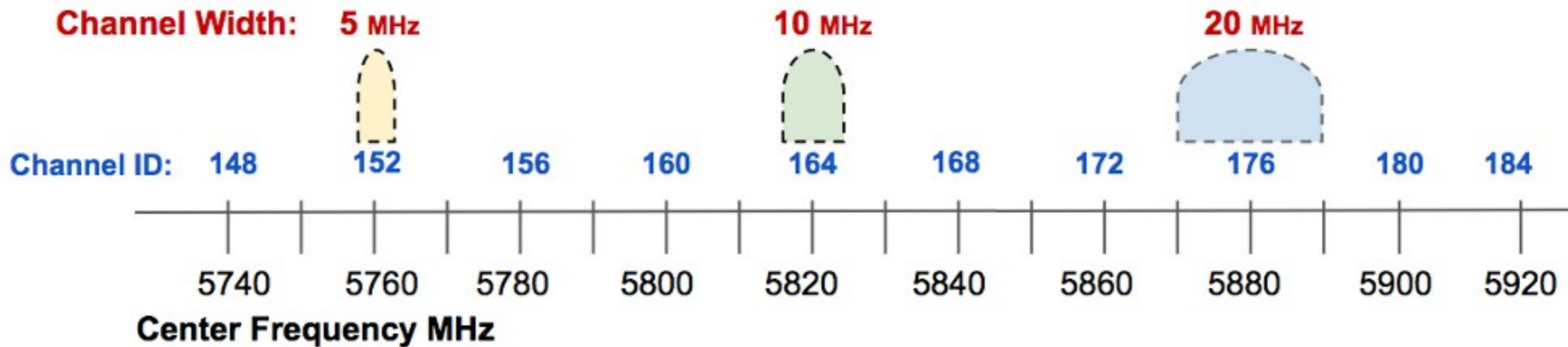

EXPLAINING NARROW VS WIDE BAND

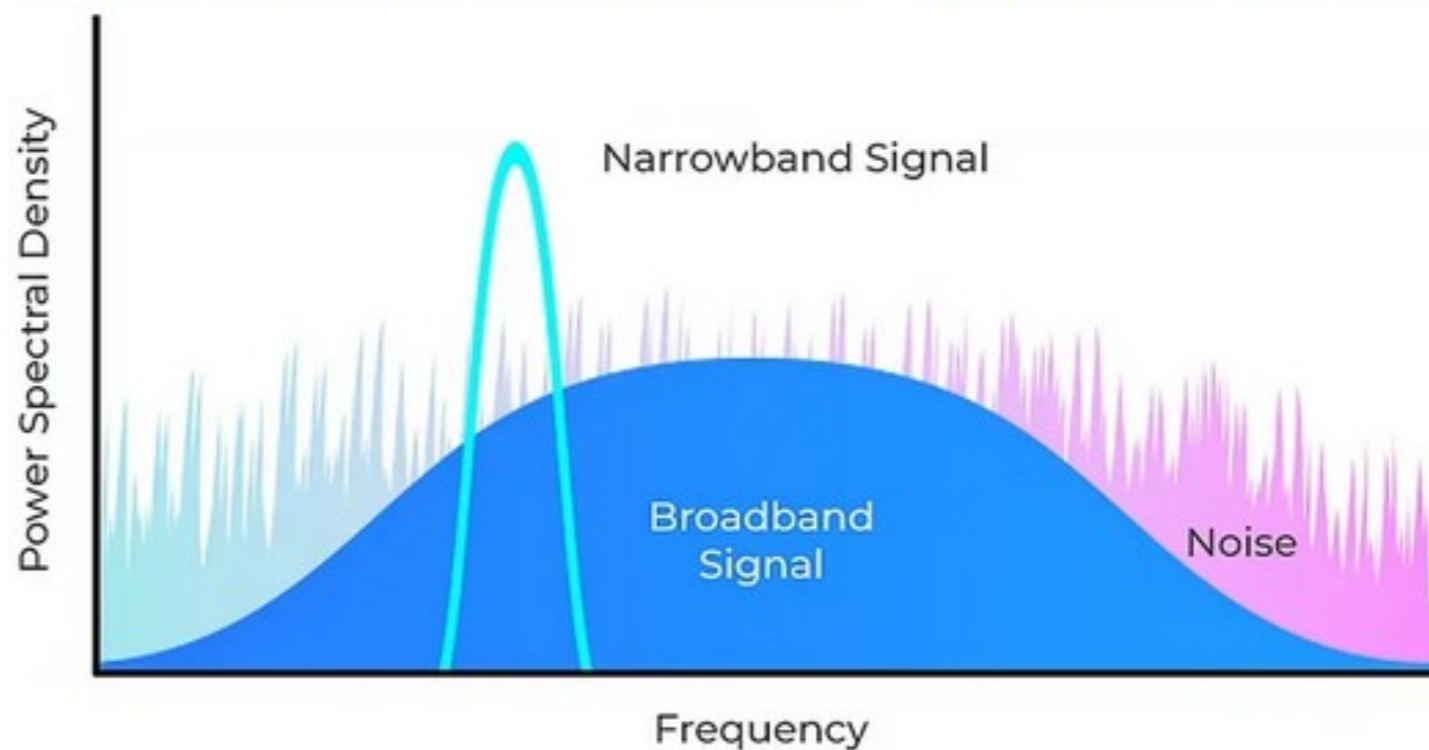

Bandwidth measurement:
High frequency minus Low Frequency
- Eg: $100.4 - 100.2 = .2 \text{ Mhz}$

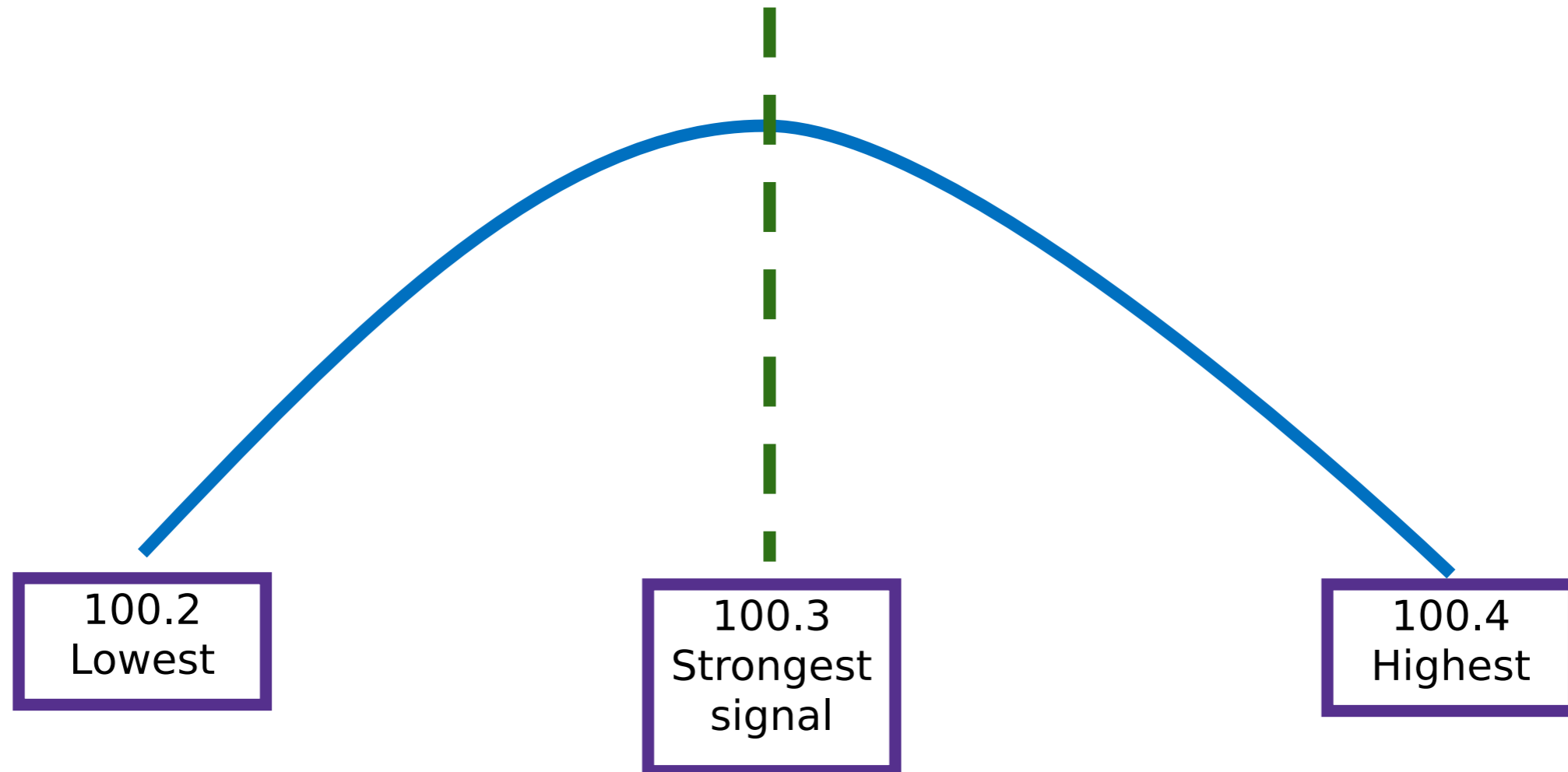

Frequency Spectrum divided

- Licensed: government regulated for broadcasting
- Unlicensed: ie: Wifi at 2.4 Ghz, 5 Ghz

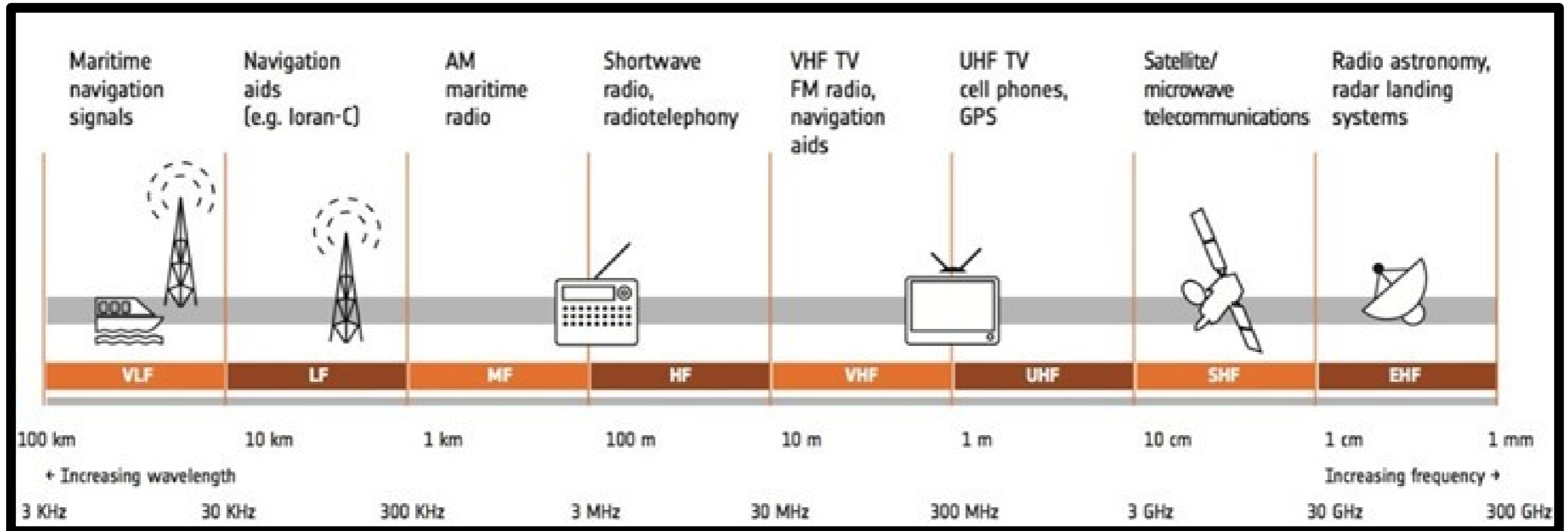

AM/FM frequencies are licensed for a specific region, ie: NYC, LA

TOP 10 Most Listened to Radio Stations



MOST POPULAR RADIO STATIONS IN THE U.S.

TOP 10	STATION	CITY	CUME
	WLTW	NEW YORK	3,609,300
	WCBS FM	NEW YORK	2,406,500
	WHTZ	NEW YORK	2,371,100
	WKTU	NEW YORK	2,360,100
	WNEW	NEW YORK	2,154,700
	KOST	LOS ANGELES	2,087,700
	KRTH	LOS ANGELES	1,970,000
	KODA	HOUSTON	1,874,800
	WINS	NEW YORK	1,761,700
	WSKQ-FM	NEW YORK	1,677,500

Inside Radio - All Rights Reserved. Source: Nielsen Avg FA24 & Wi 25 6+ Cume, Mon-Sun 6am-12am

FCC Auctions

Sell blocks of frequencies, ie: Verizon, AT&T
For commercial use

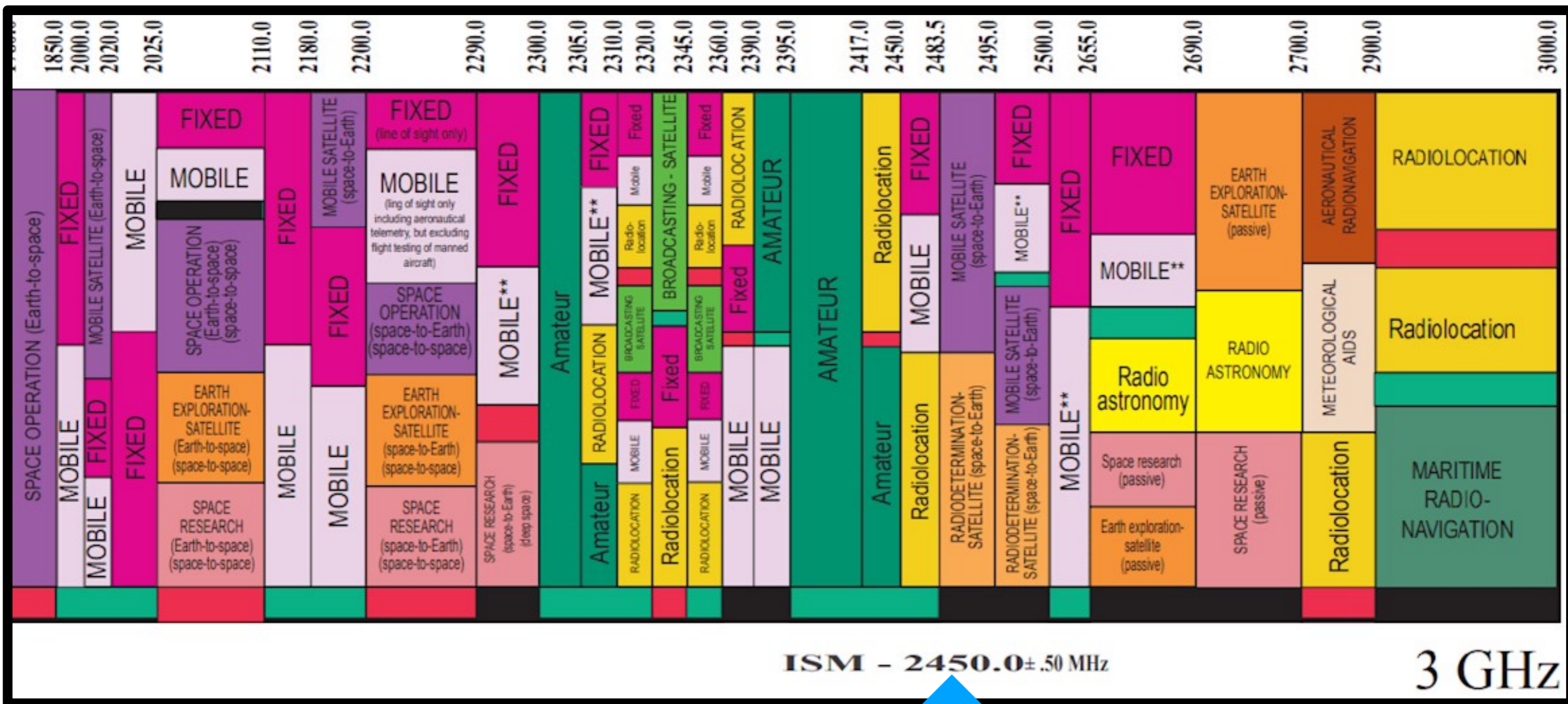

ISM band is 2.4
Ghz, ie: Wifi

Unlicensed Frequencies

- 2.4 GHz & 5 GHz
- Bluetooth at 2.4 GHz
- Infrared: remote controller
 - NFC: Near Field Communication
 - RFID: chip card

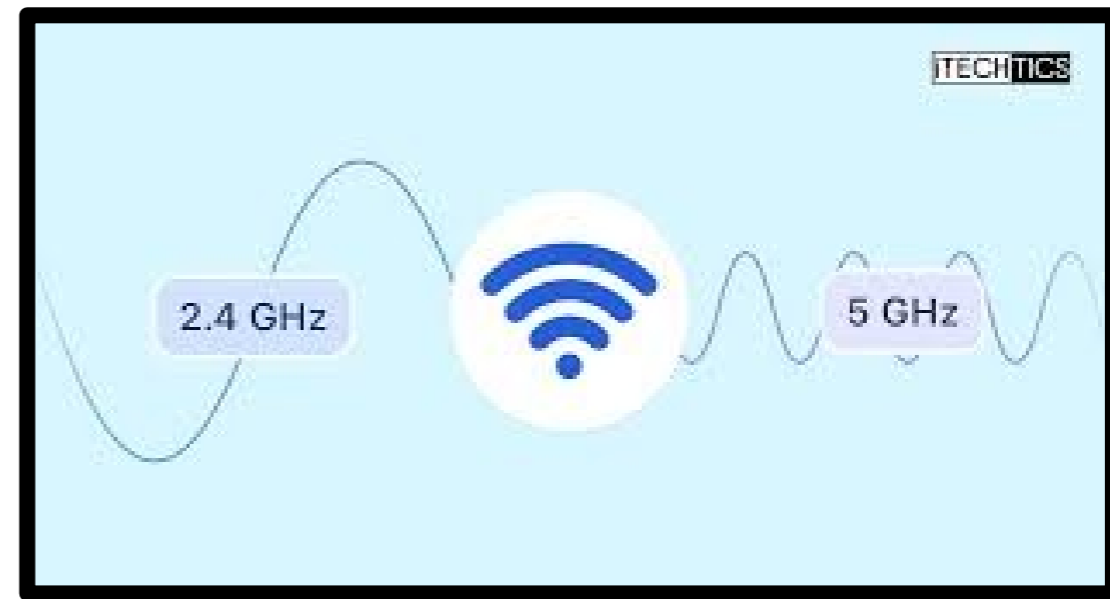

Coexistence of Bluetooth and WLAN on 2.4 GHz Frequency Band

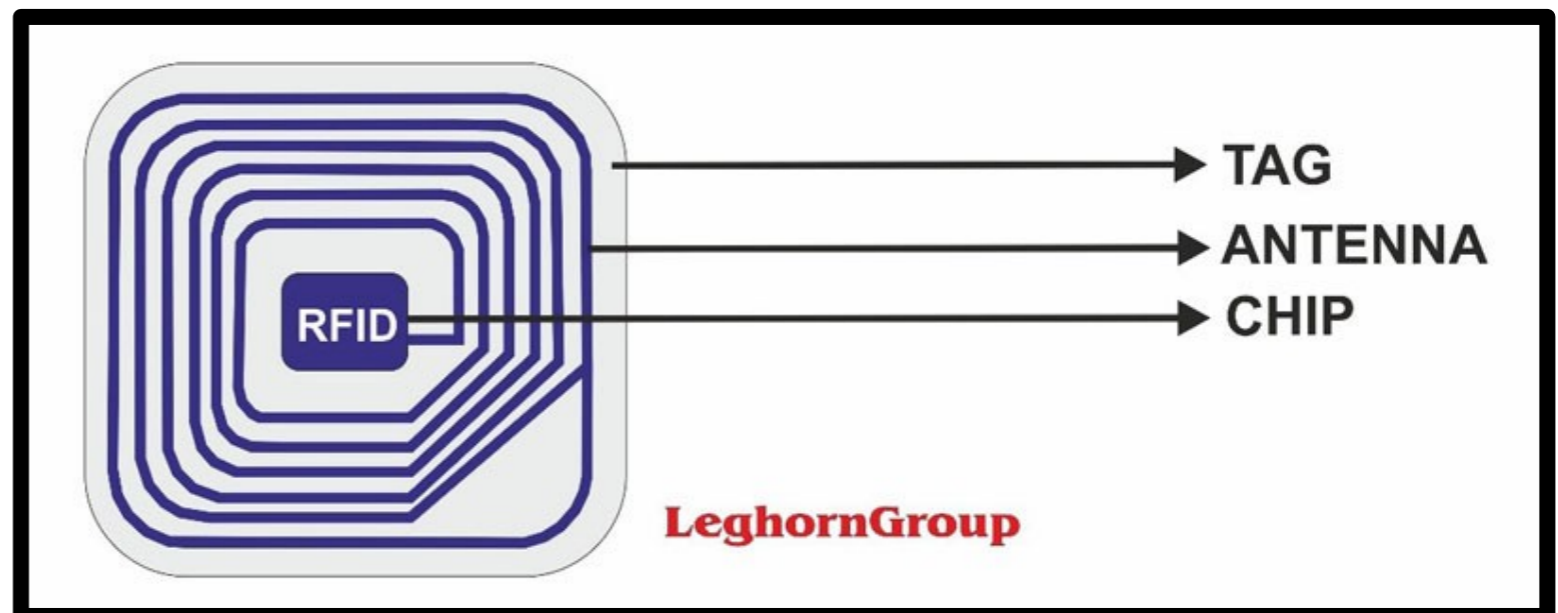
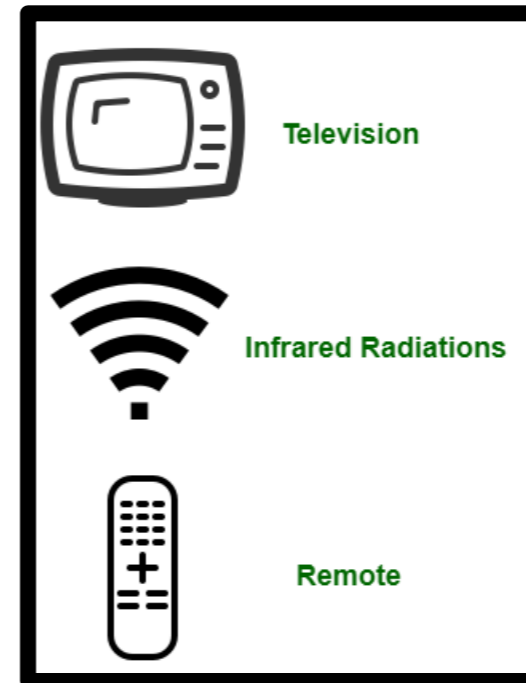
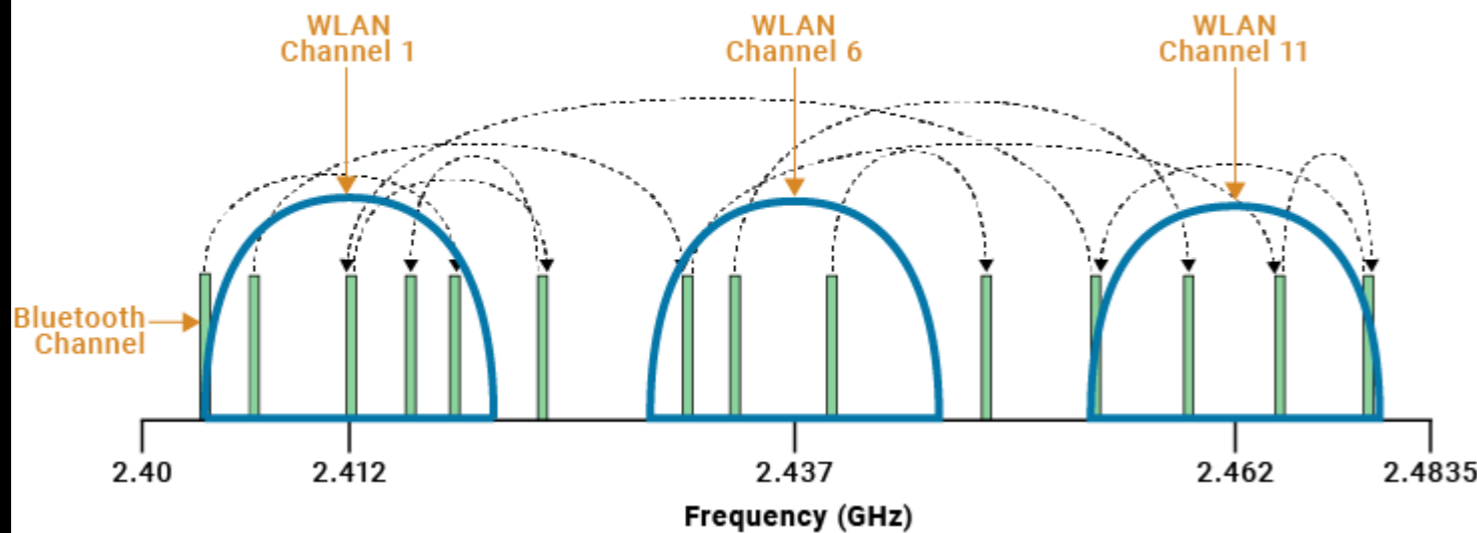

2.4 Ghz spectrum

- Best channels to use are 1, 6 and 11
- 1, 6, 11 do not overlap/interfere with each other
- 3 non-overlapping channels

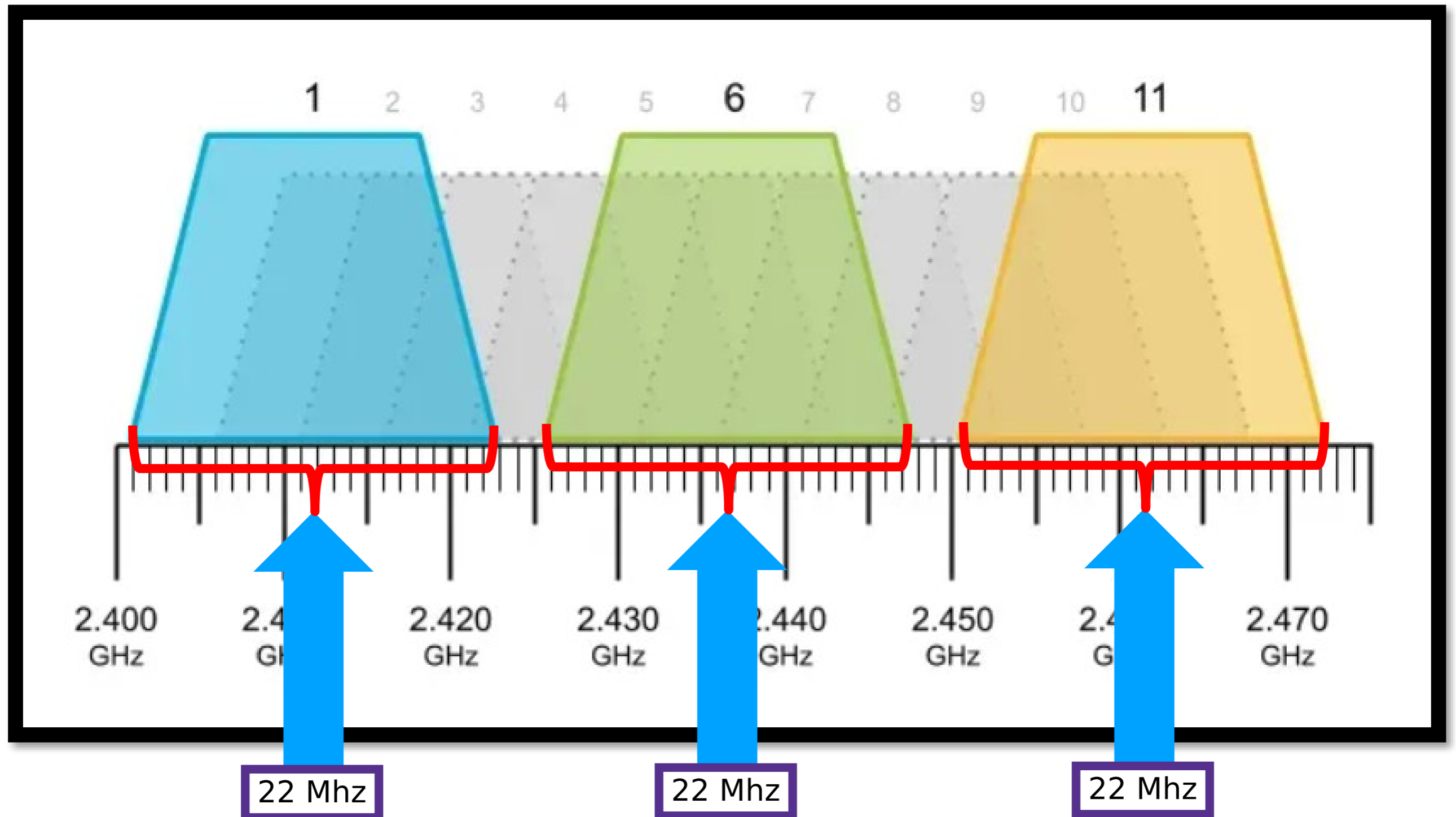

5 GHz spectrum

- Can be split into range of channels
- Based on channel width

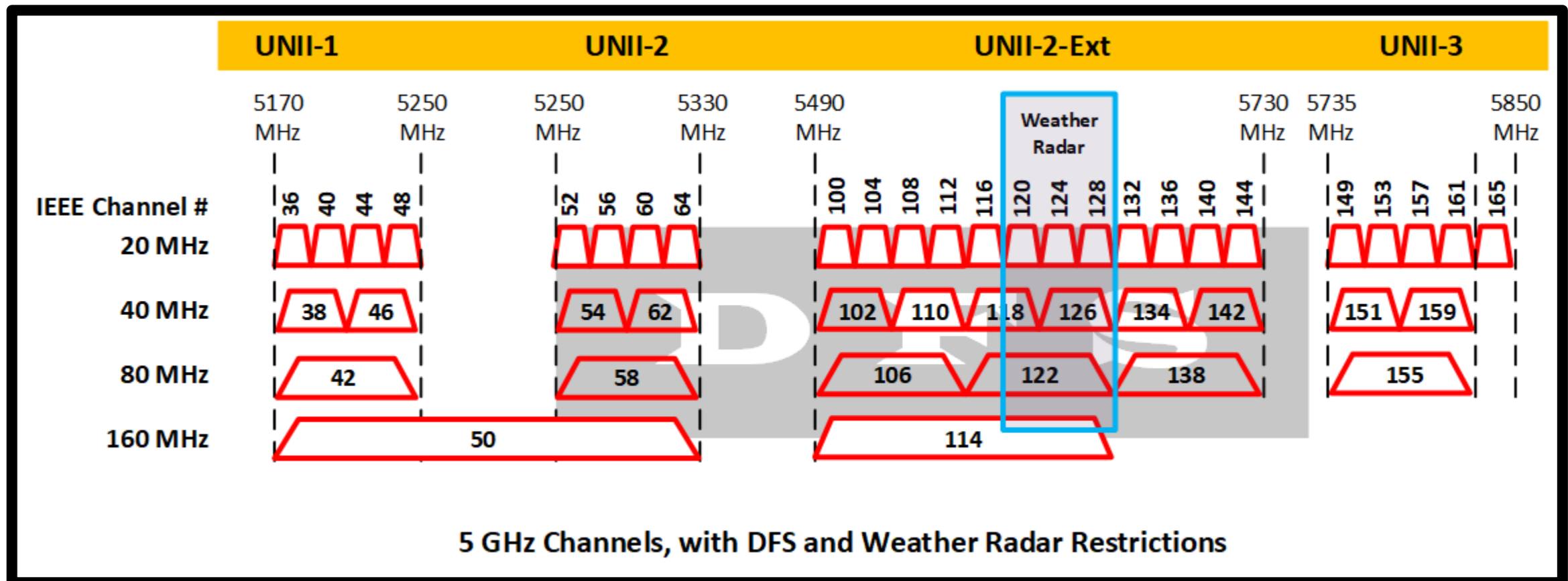
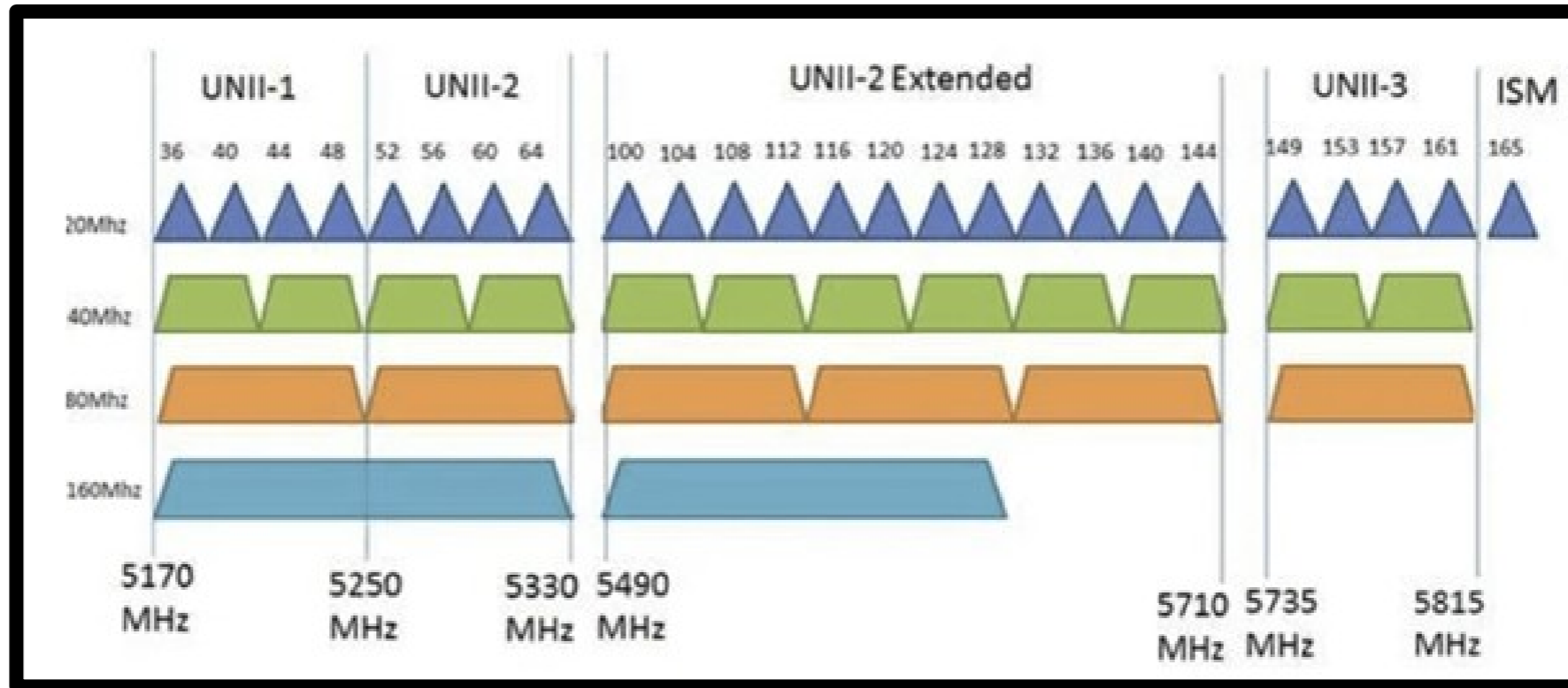

2.4 Ghz travels further than 5 Ghz

- 2.4 Ghz: lower data rate
- 5 Ghz: higher data rate

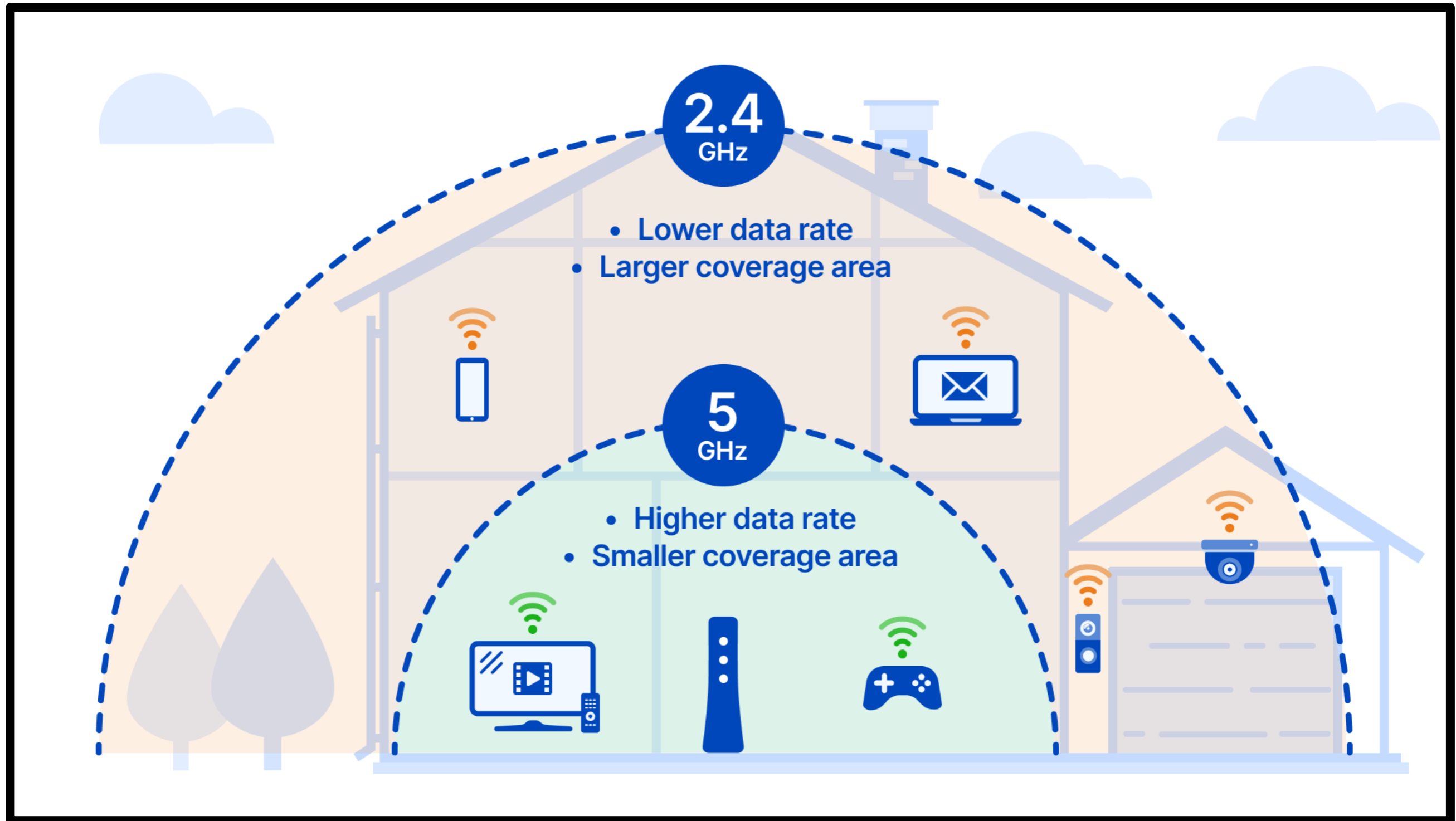

6 GHz – new spectrum - 59 channels

6 GHz Band – Total Spectrum 1200 MHz



6GHz – Preferred Scanning Channels (PSC)

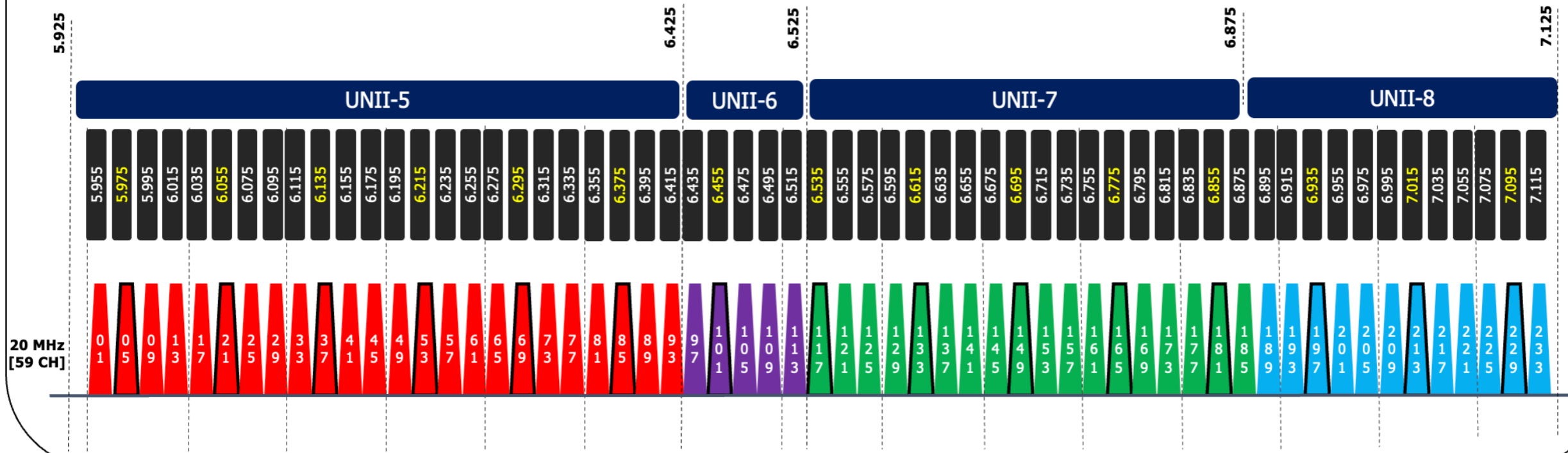

- Hardware Amplifier
- Increases amplitude
 - Does not change frequency

Sound Amplification

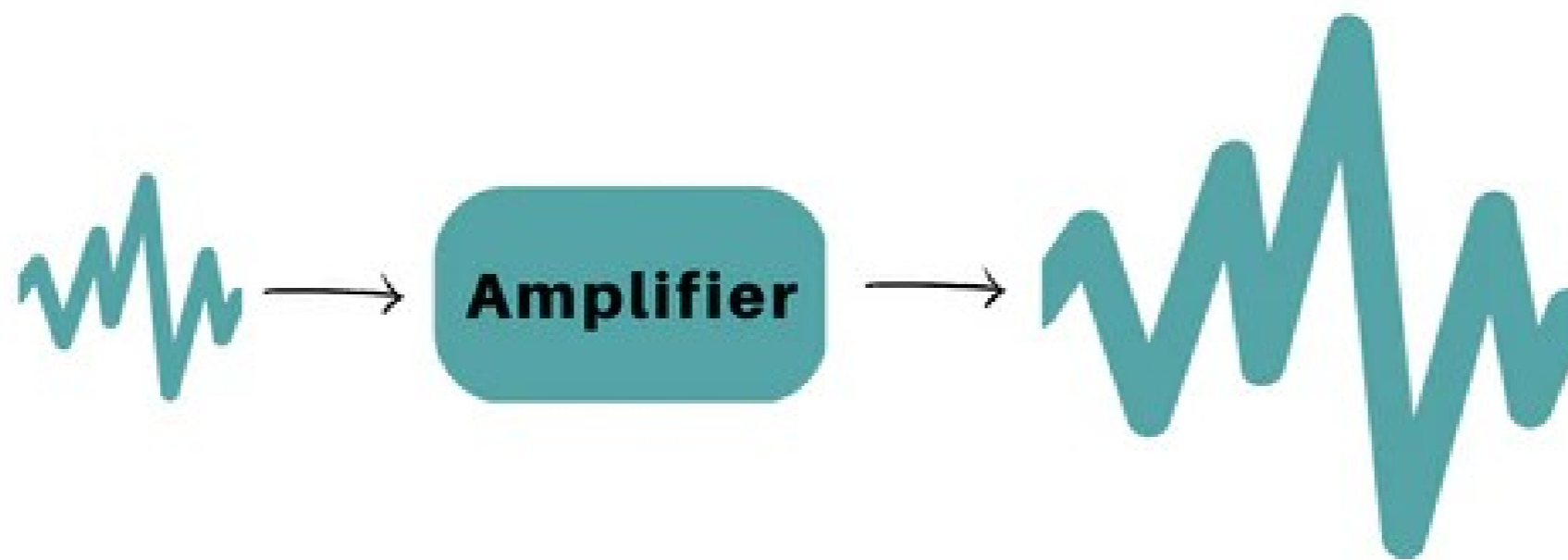

INPUT

Lower amplitude
sound wave.
(Softer)

OUTPUT

Higher amplitude
sound wave.
(Louder)

Hardware Amplifier

- Noises in signal are amplified as well

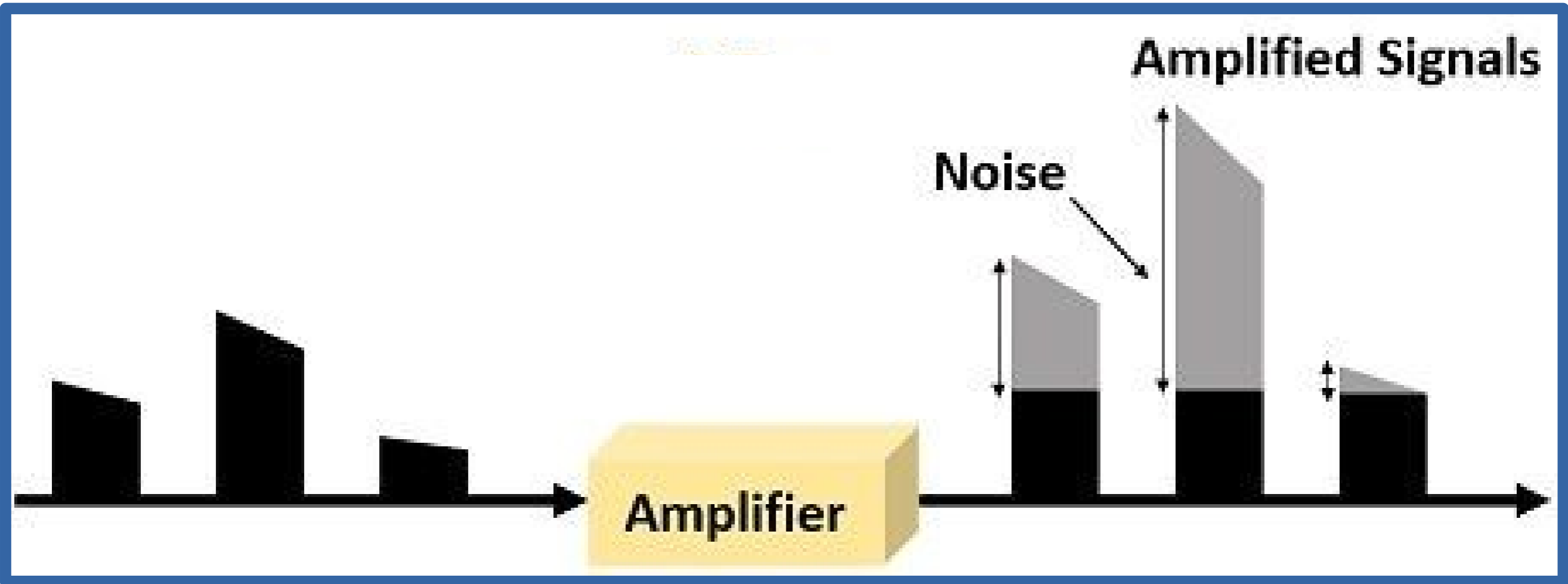

- Signals die out and get weaker
- Known as attenuation
 - Amplifiers are used to address attenuation

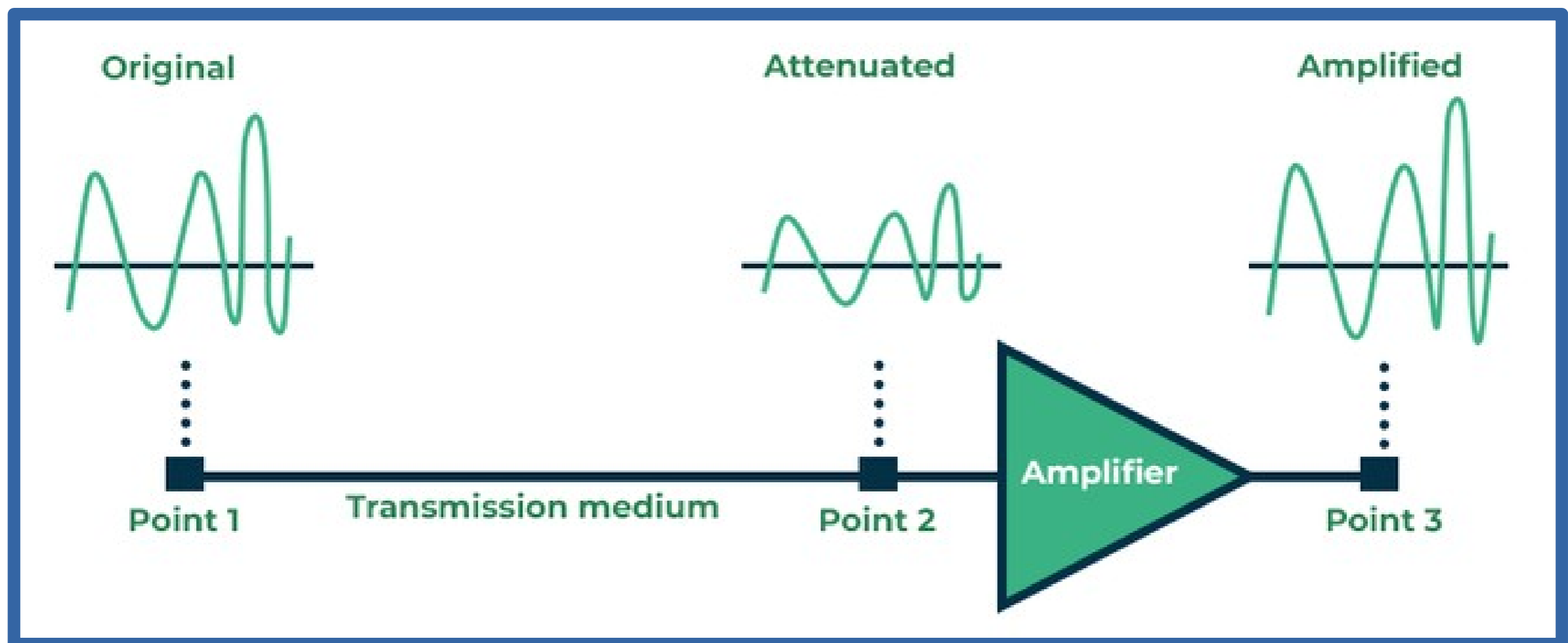
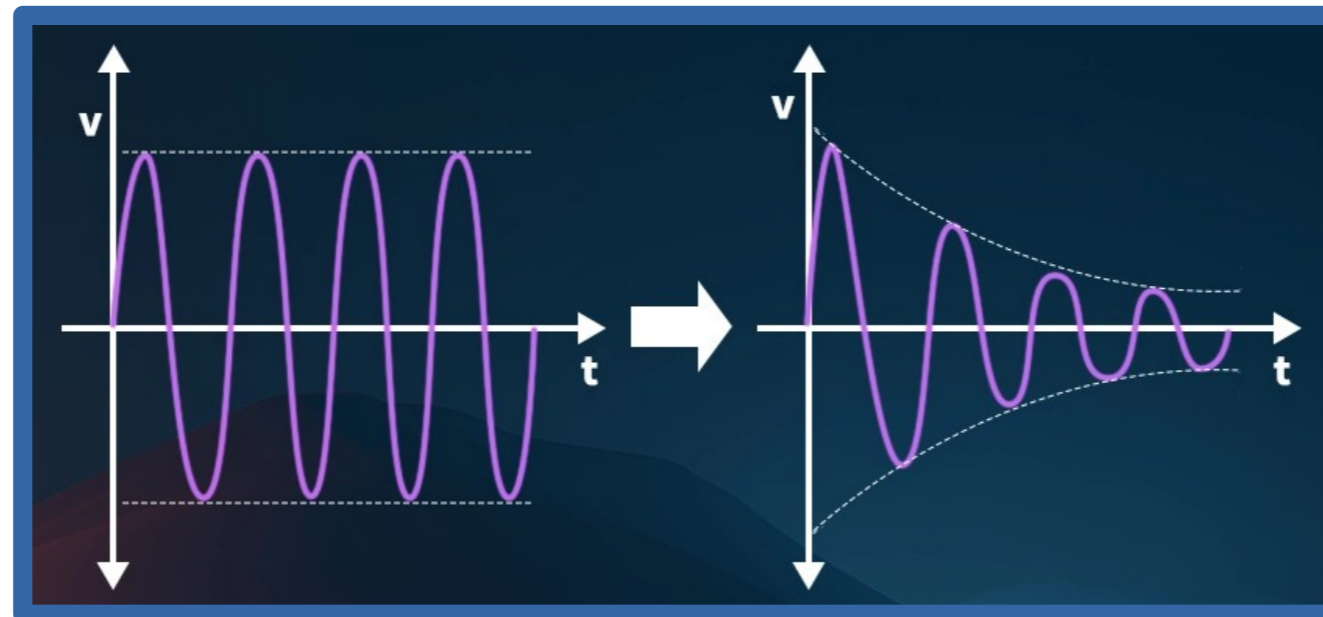

Analog amplifiers can only increase amplitude because amplifier does not know what signal should be

- Unlike digital signals
- Digital signals can be regenerated accurately
- Regenerator: can tell if signal is 0 or 1 and regenerate

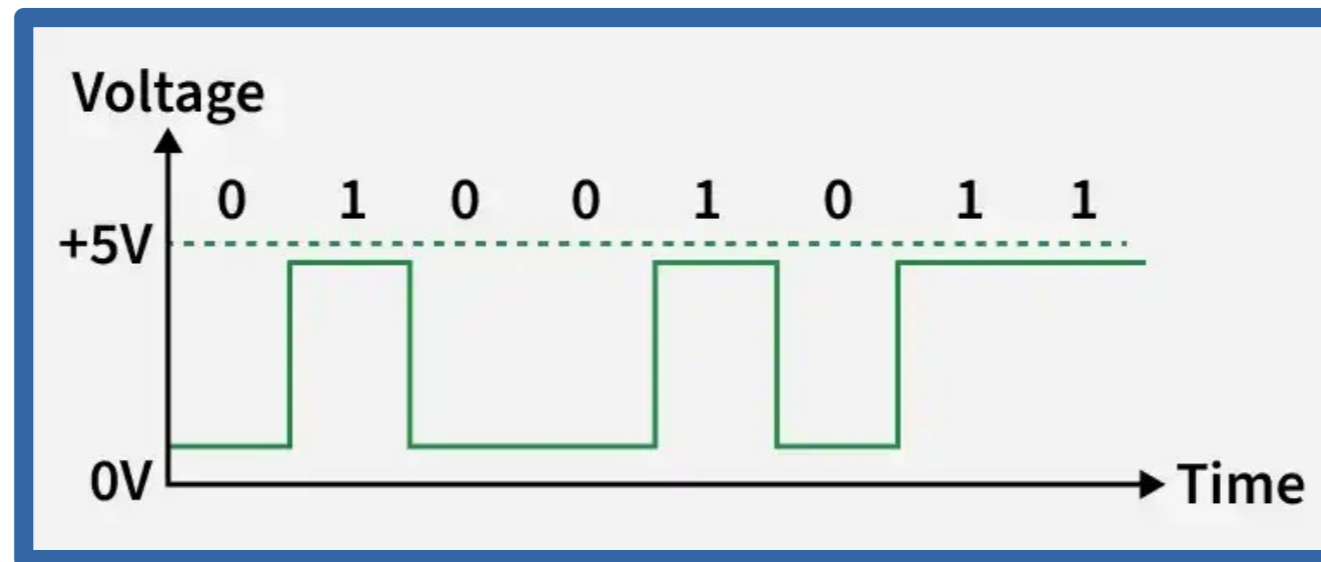

Regeneration

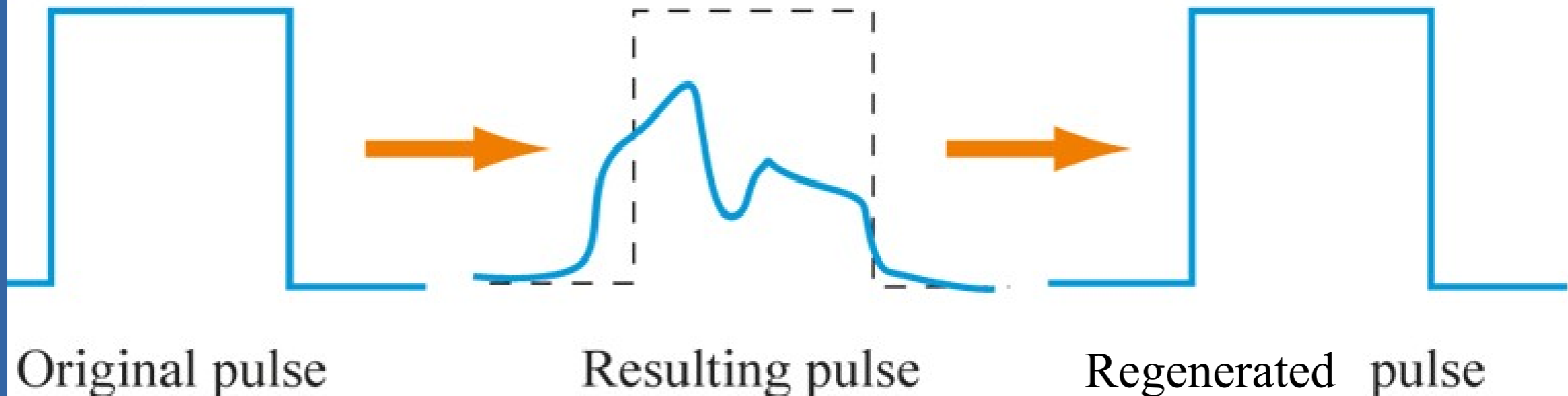

Regenerating repeaters bring their own noise
- 4 or 5 in a row can introduce too much noise into signal

5-4-3 Rule
5 segments
4 regenerating repeaters
3 network segments with computers

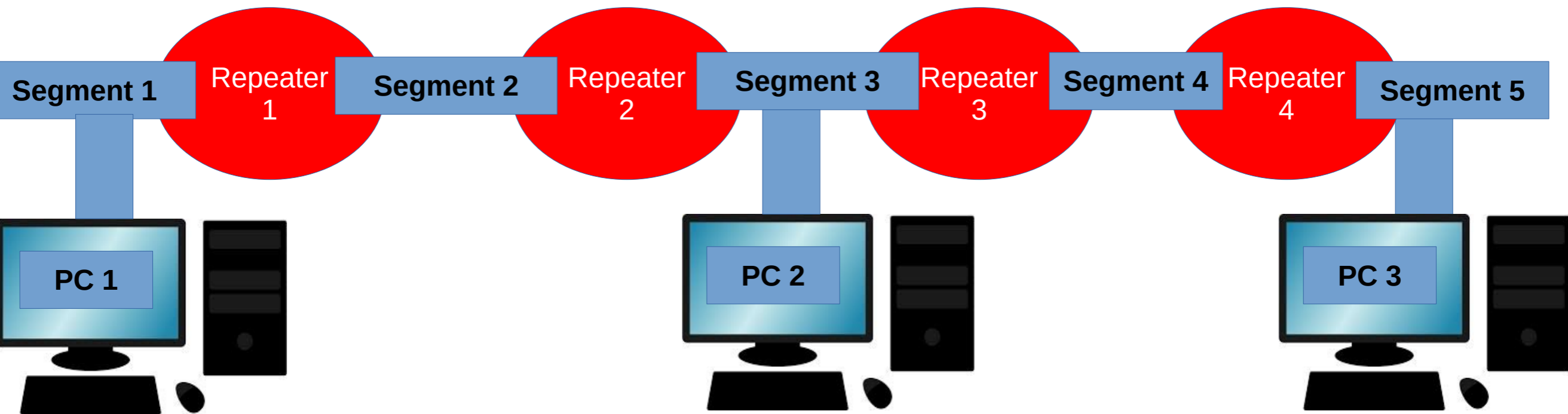
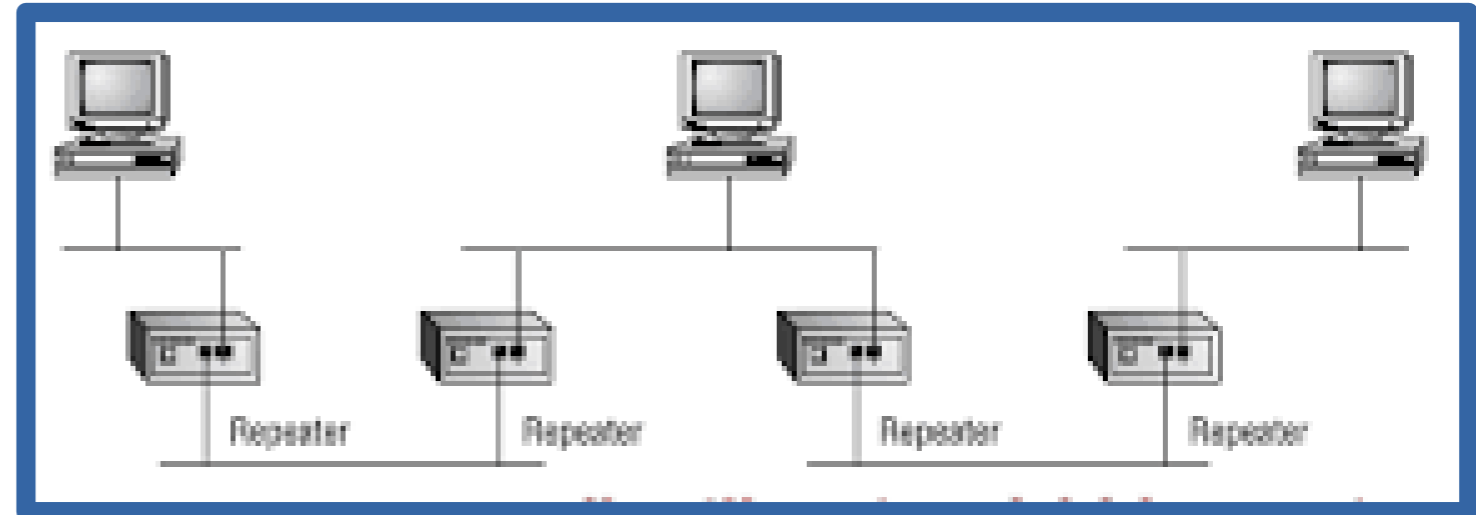

- # Regenerating repeater
- Boosts signal
 - Layer 1
 - No intelligence, just adds power

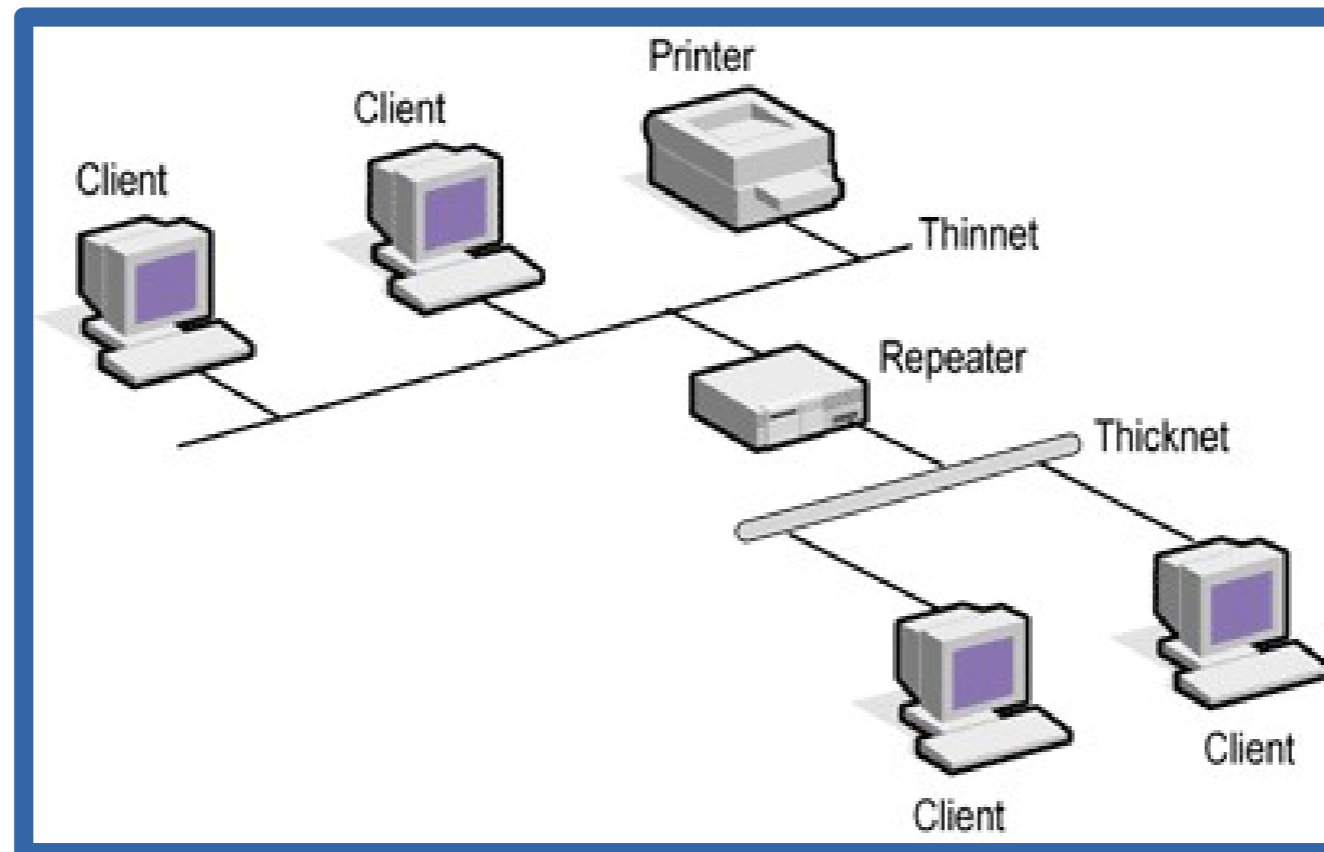
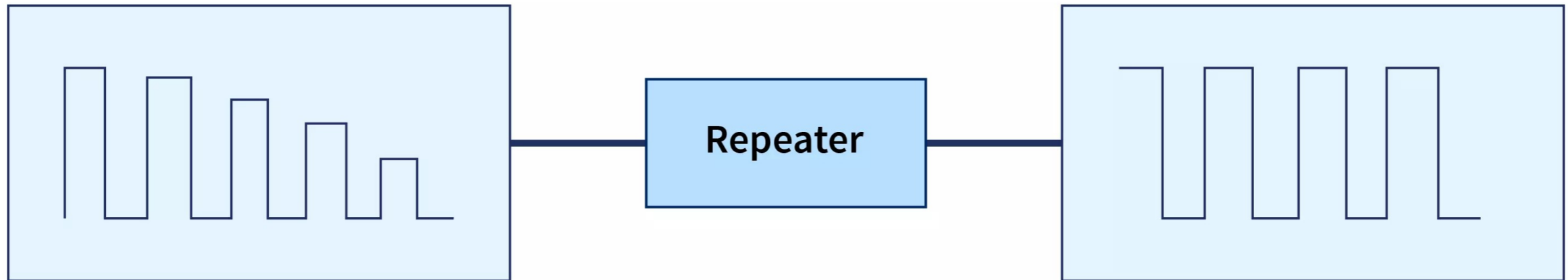

Multiple Wifi Networks in one building
- Place each one on different channel

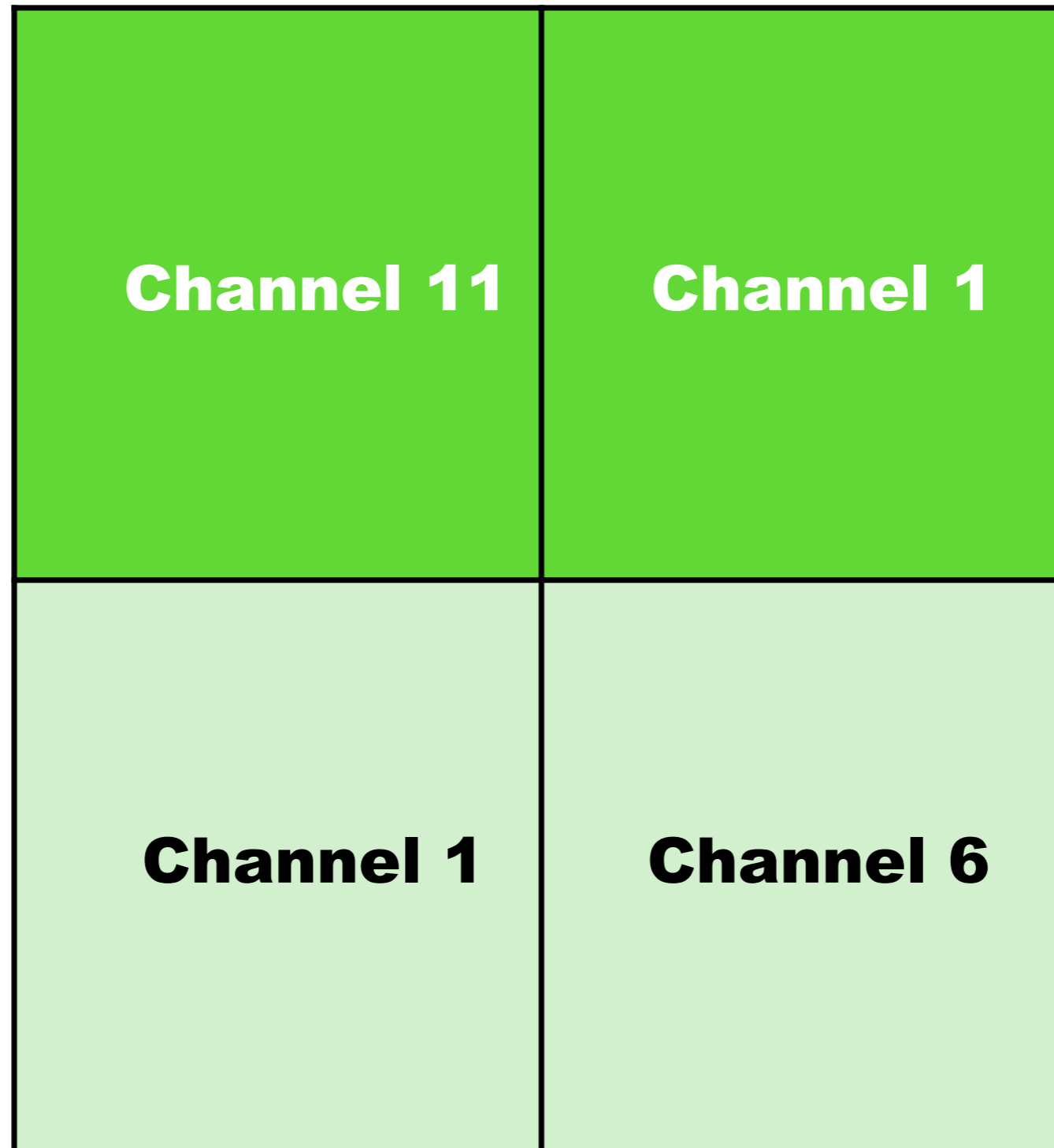

Technicians can measure signal strength in building

Open Space

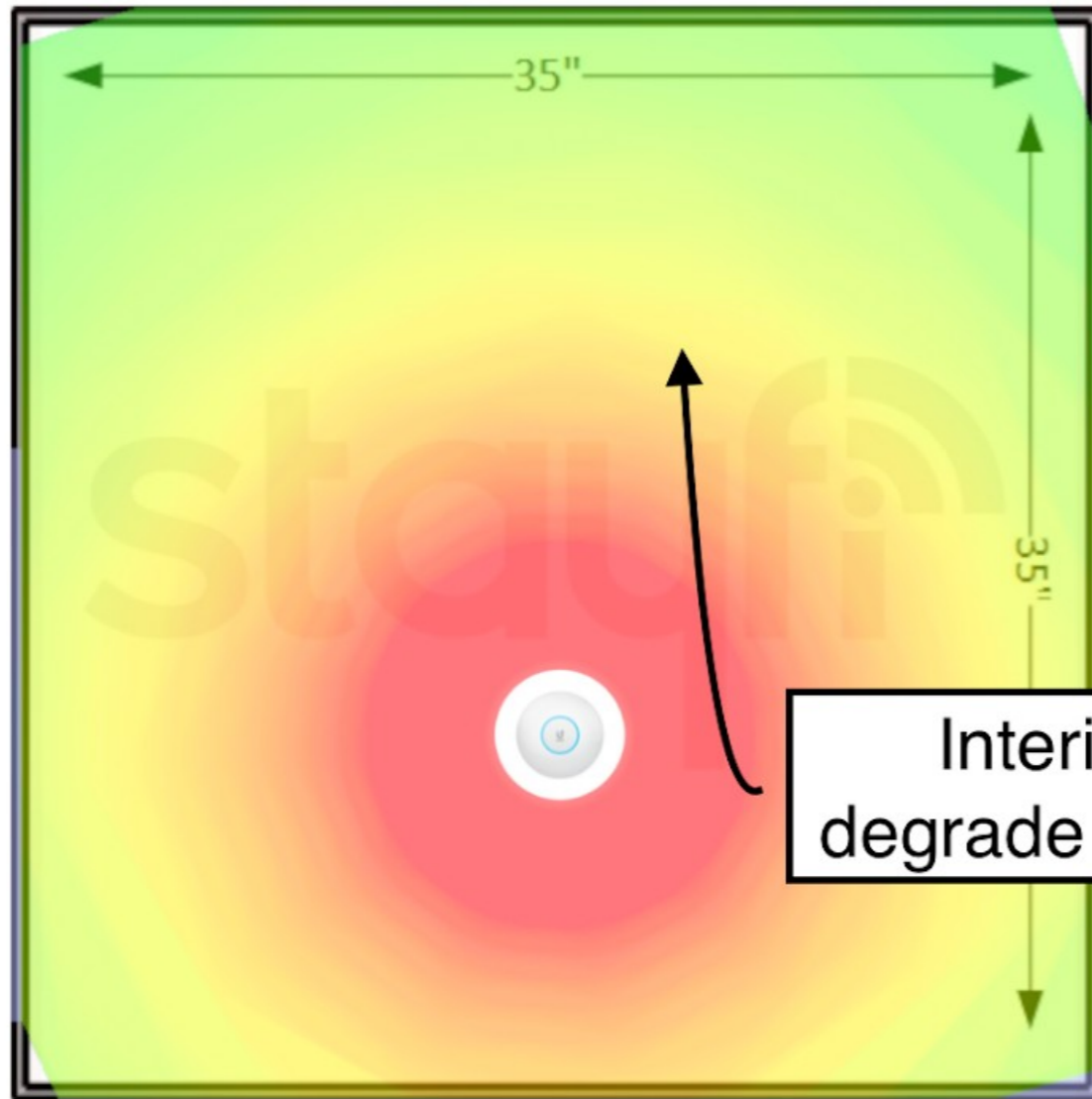

Space with 2 Interior Walls

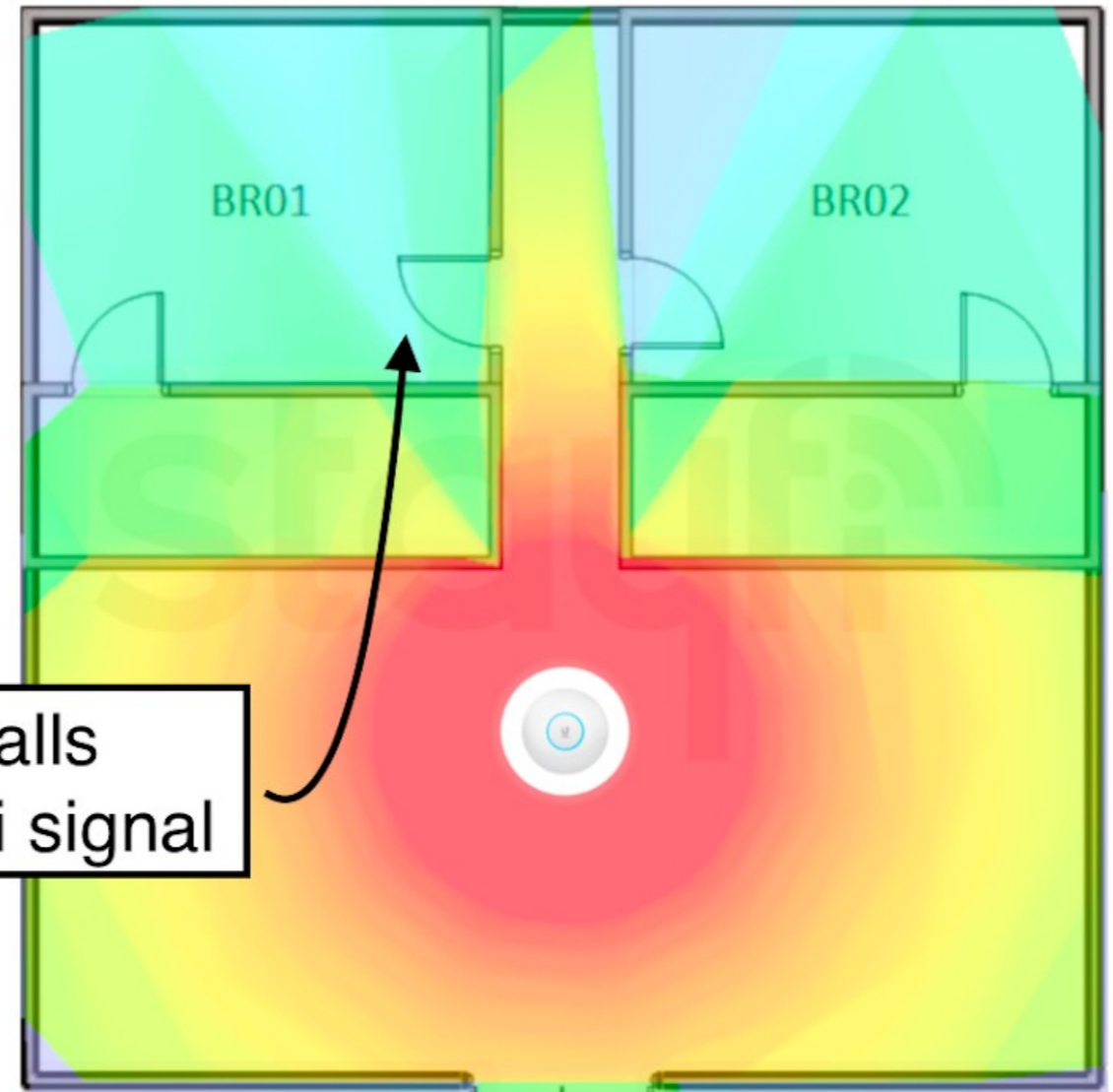

Interior walls
degrade WiFi signal



Sine Wave 180 Degrees out of phase - Cancels out creates dead spots

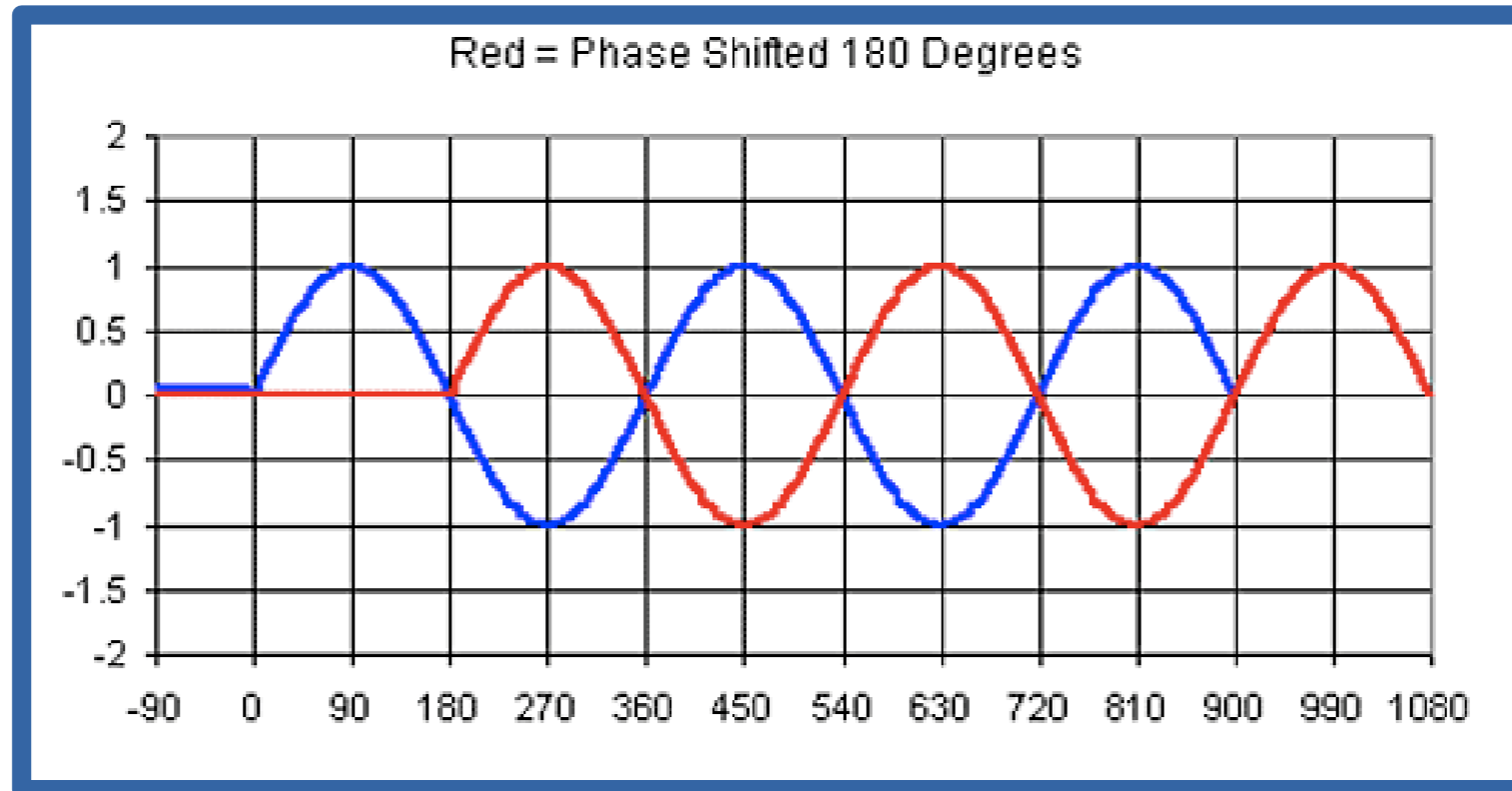

180 DEGREES OUT OF PHASE

Will Result in Silence When Signals are Combined

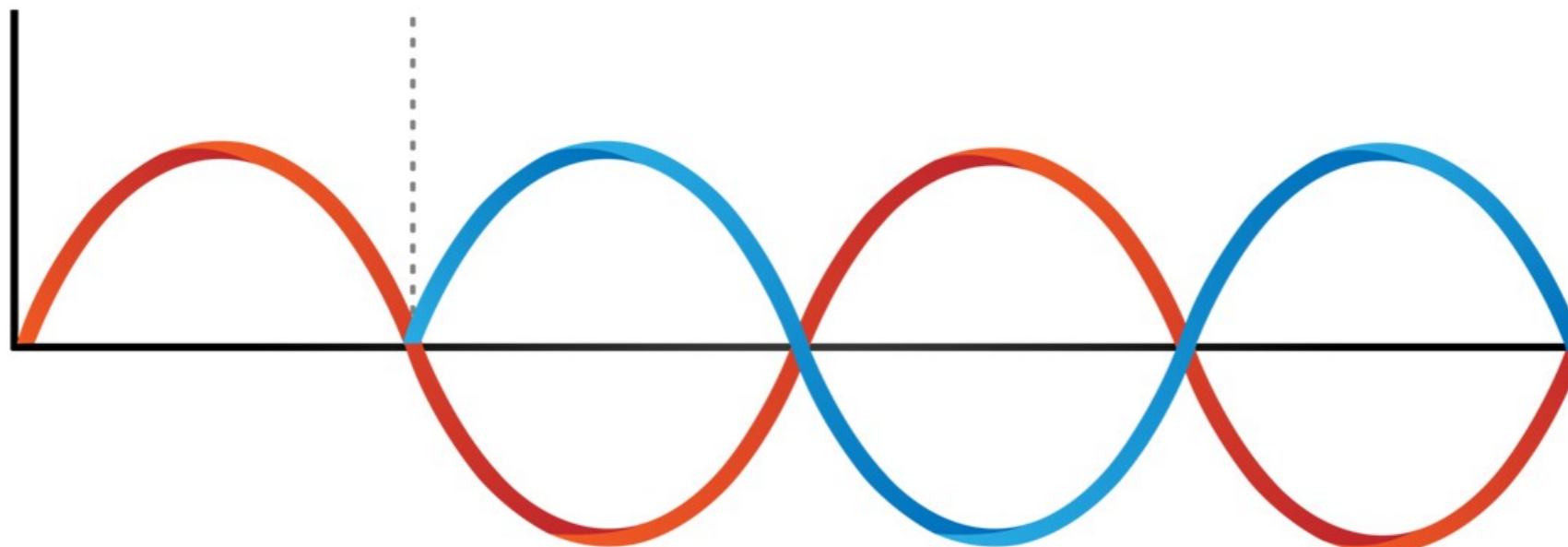

Bandwidth = High Frequency - Low Frequency

- An 88.0 MHz to 88.2 MHz channel has a bandwidth of 0.2 MHz (200 kHz)

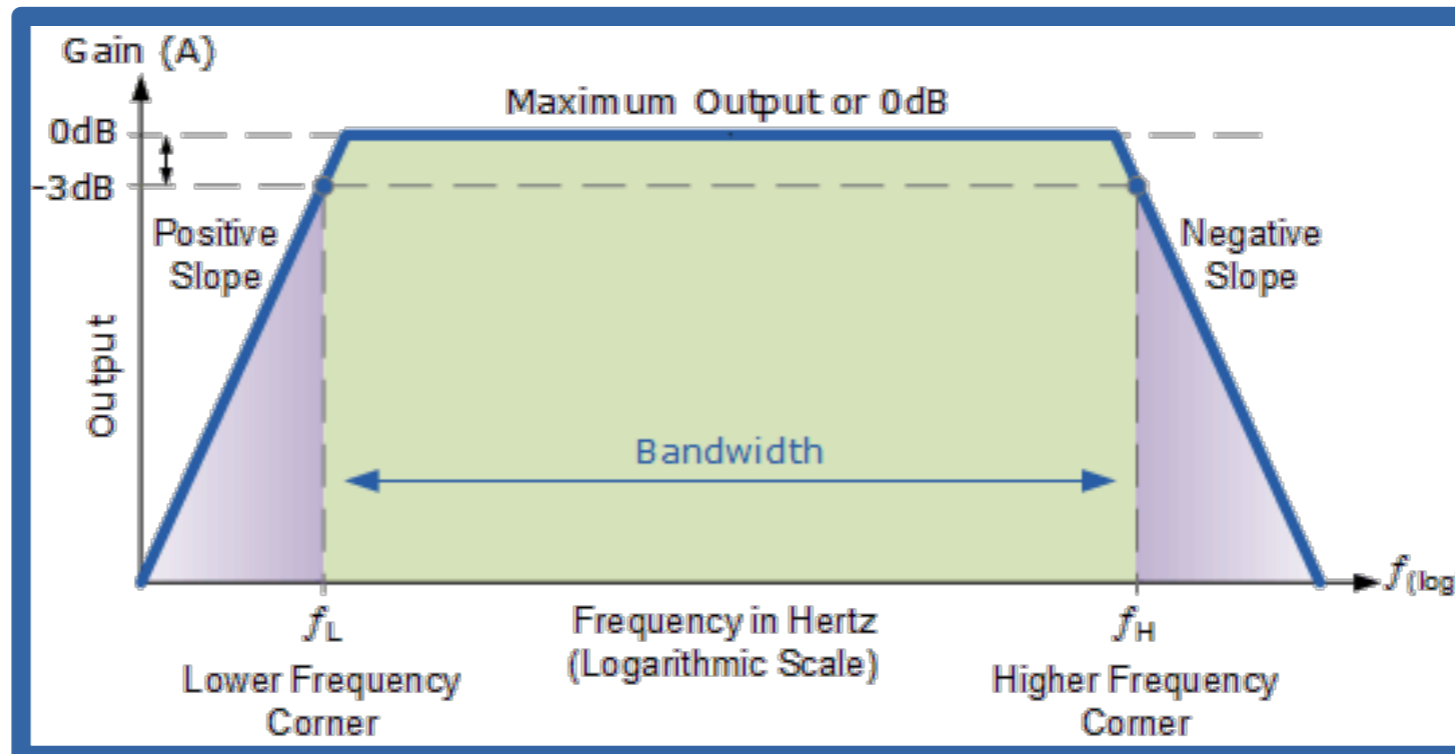
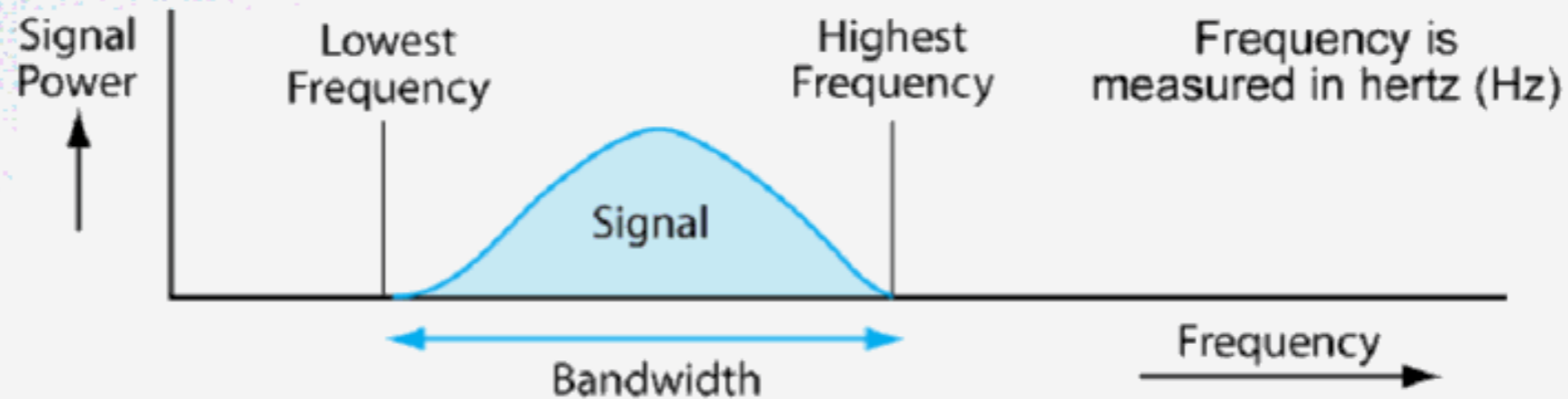

Layer 3 Packet inside Layer 2 Frame

- Frame gets changed out going from wired to wireless and wireless to wired

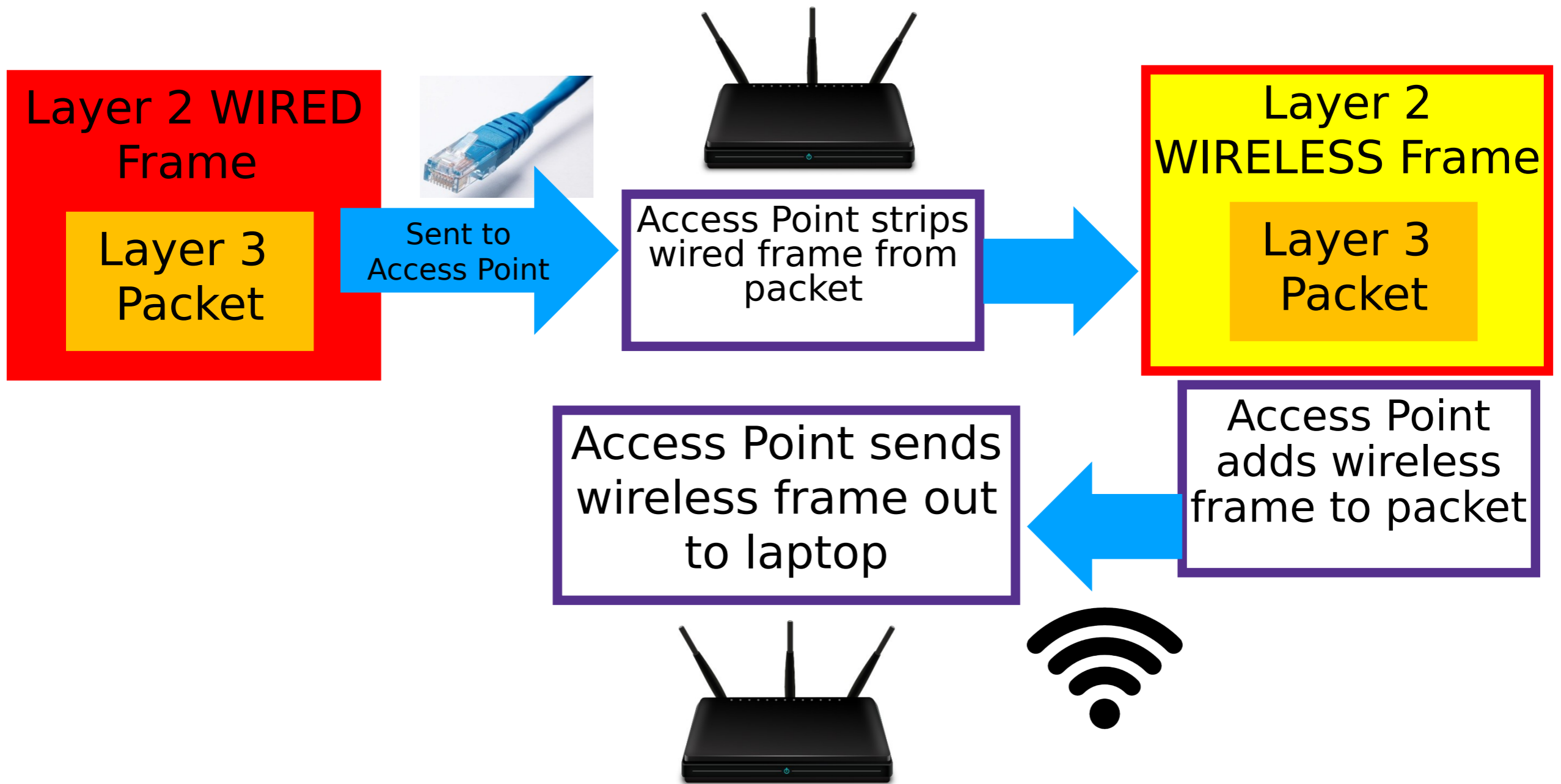

Process of placing the packet inside the Layer 2 frame is known as encapsulation

Wireless Access Points should be connected to switch
This will enable access to all services, ie: printer, server via any access point



Wireless Access Point #1



Wireless Access Point #2



Switch



Printer



Server Resources