

USB-C

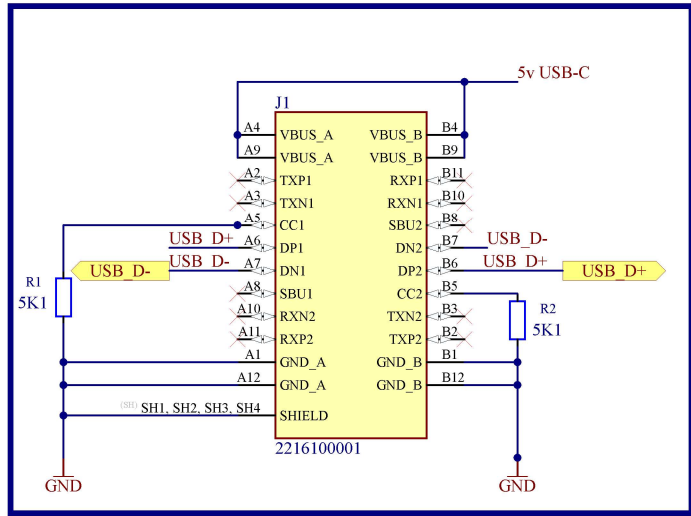

Charging Module

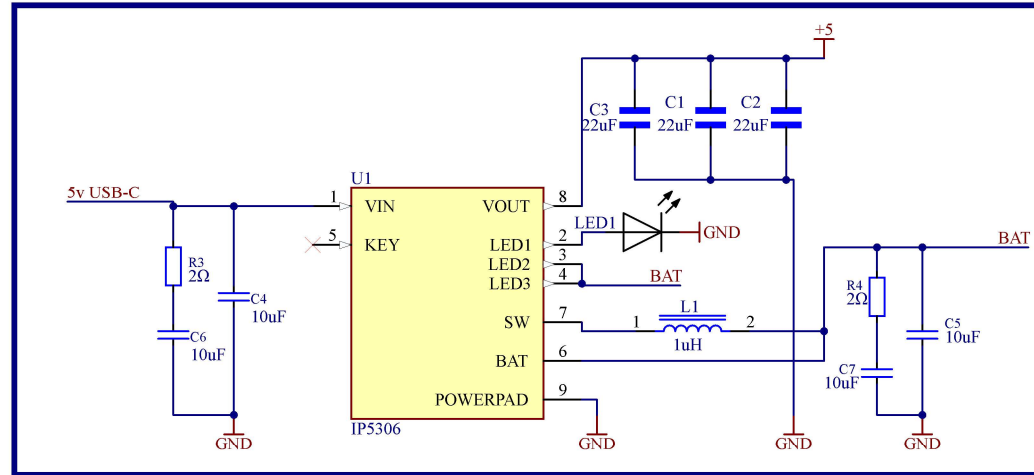

Battery Connector

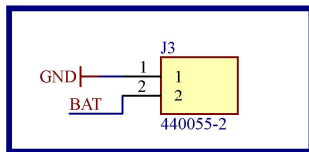

LDO Regulator 5V to 3.3V

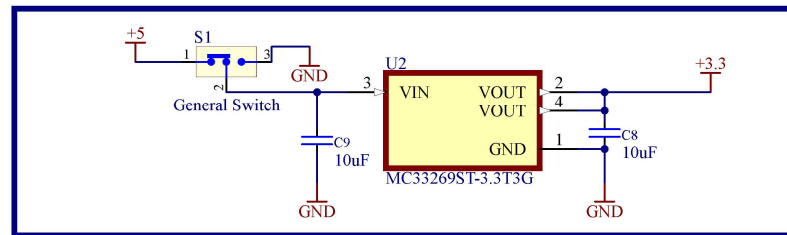

Ring Encodeur

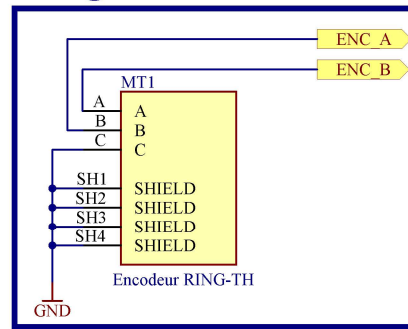

1.28" TFT Screen

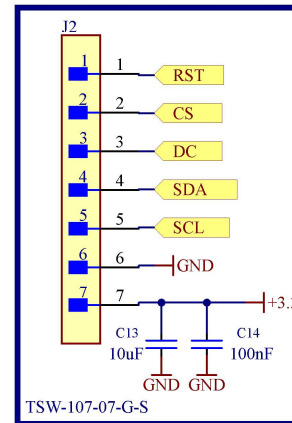

TSW-107-07-G-S



Project :		Rev :
Designer :	Reviewer :	
Last Edit : 18.05.2026	Page : 2 / 3	
File : I_O.SchDoc		

ESP32-S3 Wroom

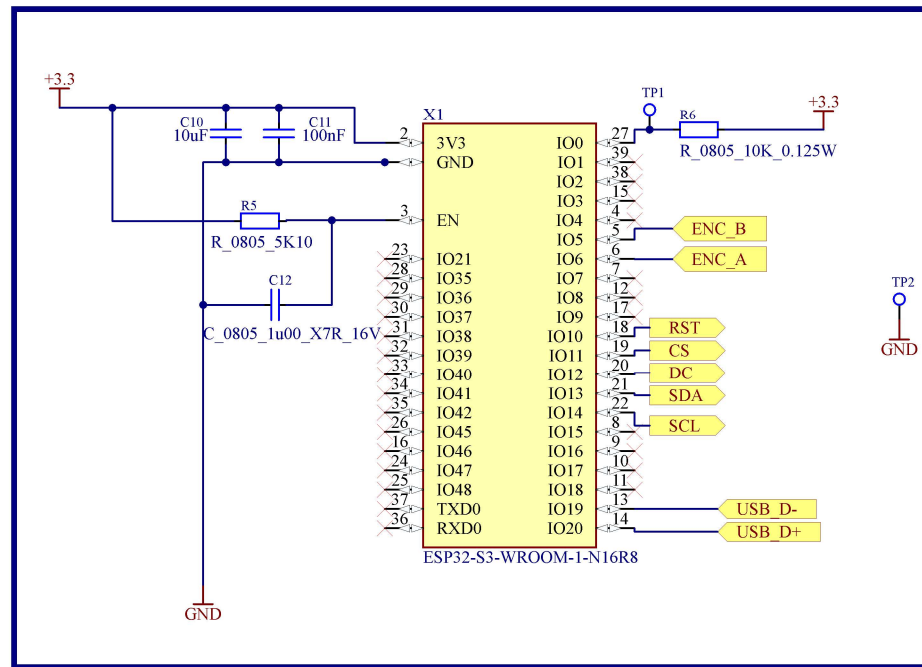

Project :		Rev :	
Designer :		Reviewer :	
Last Edit : 18.05.2026		Page : 3 / 3	
File : Esp32.SchDoc			