

April 30 Notes Antennas - 2 Types

- Omnidirectional: broadcasts in all directions
- Directional: narrow stream of data; aimed at satellites

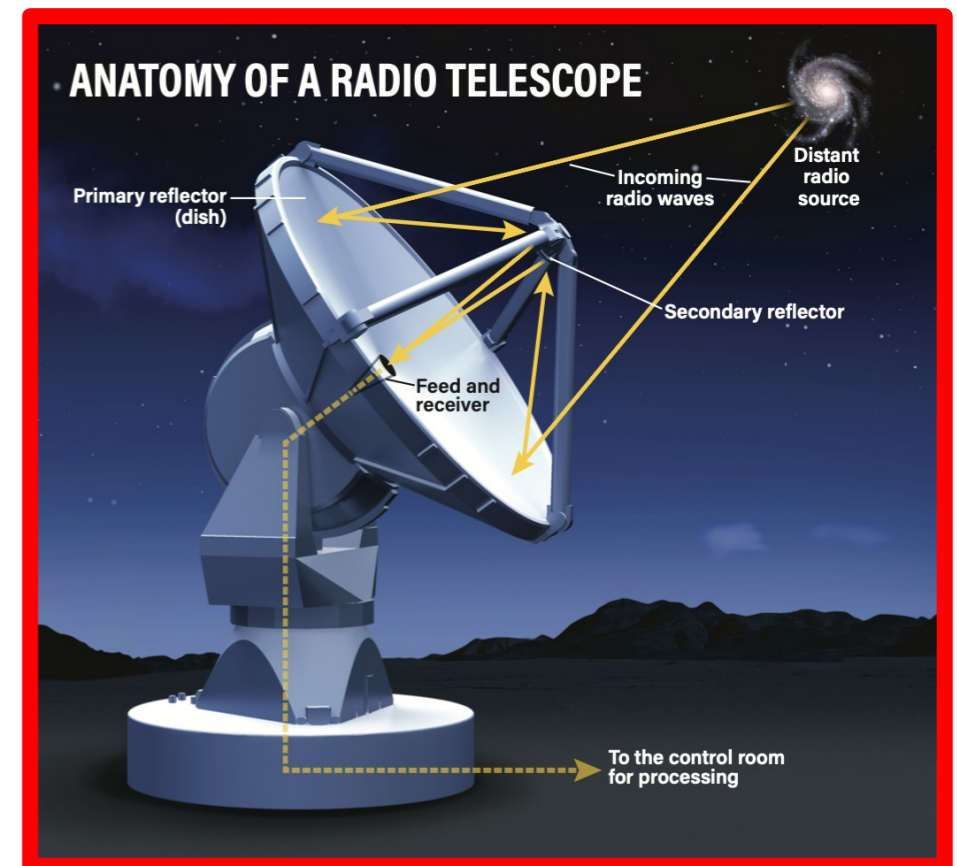

Encapsulation in action
- 802.11 > Layer 2 protocol

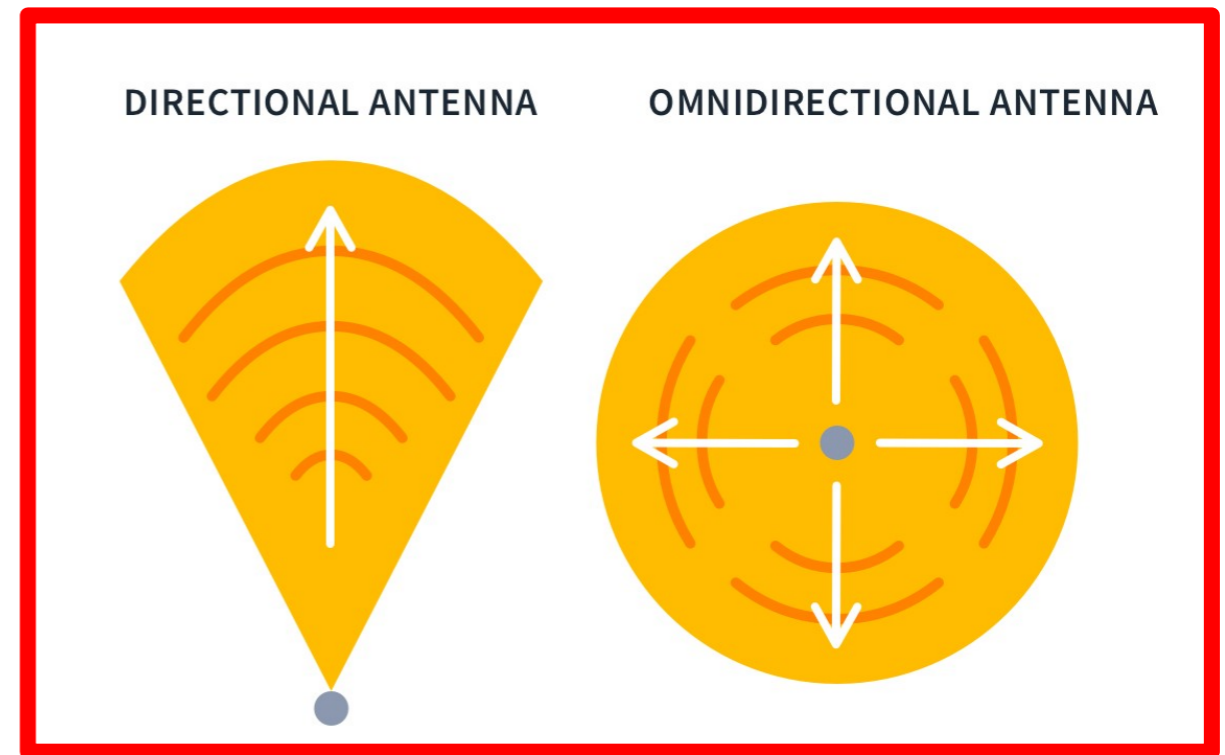
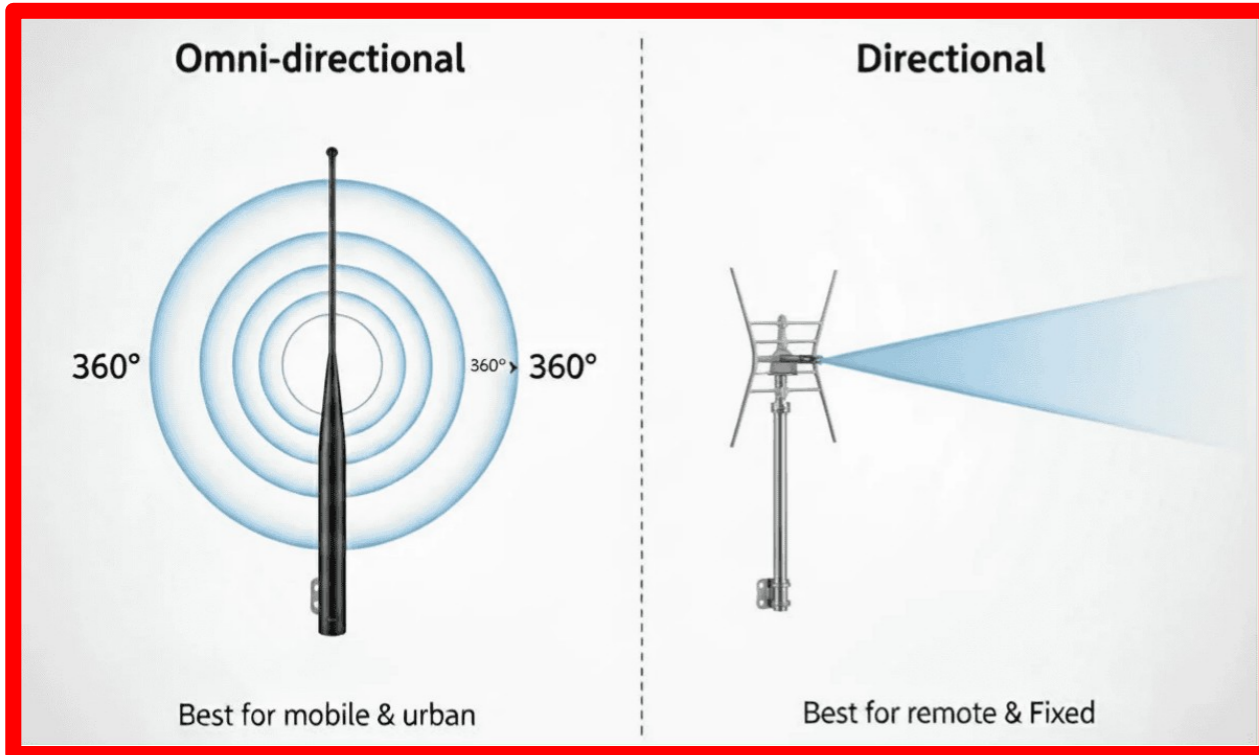
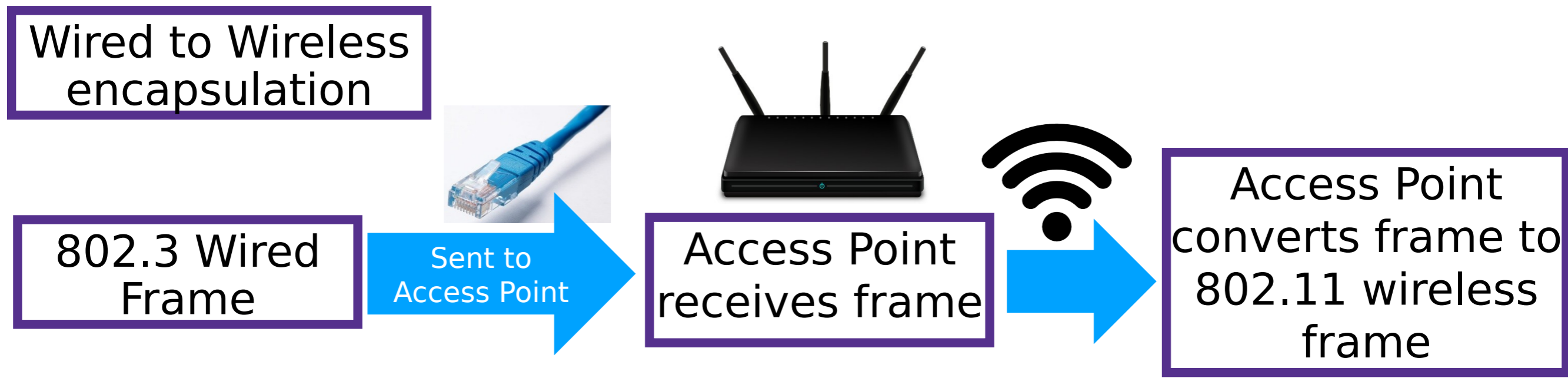
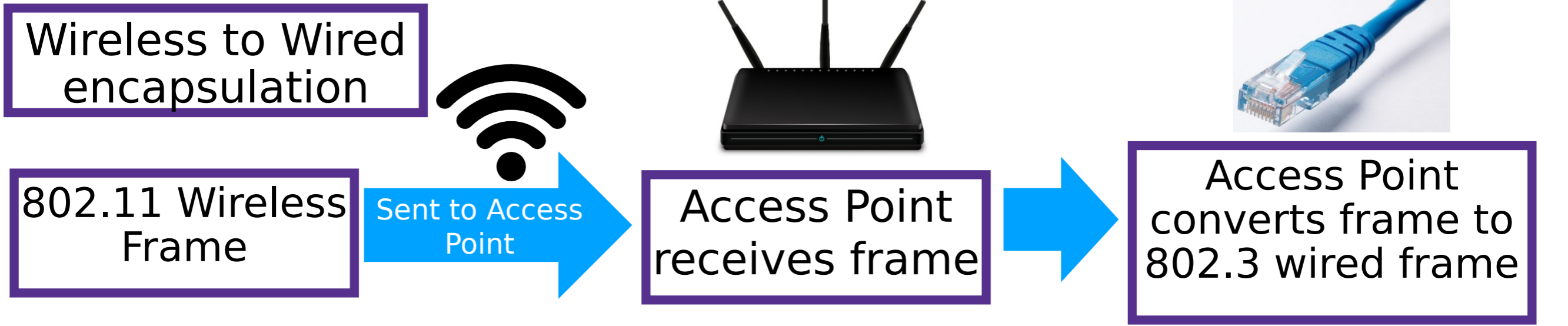

**Wireless Frame
(802.11)**

A black Wi-Fi signal icon consisting of three curved lines above a small circle.

Ethernet Frame

An icon of a black Ethernet cable with a blue RJ45 connector.

Wireless is Layer 2

- Get Zeros and Ones into Wifi signal
- 802.11 protocol uses Layer 2 frames

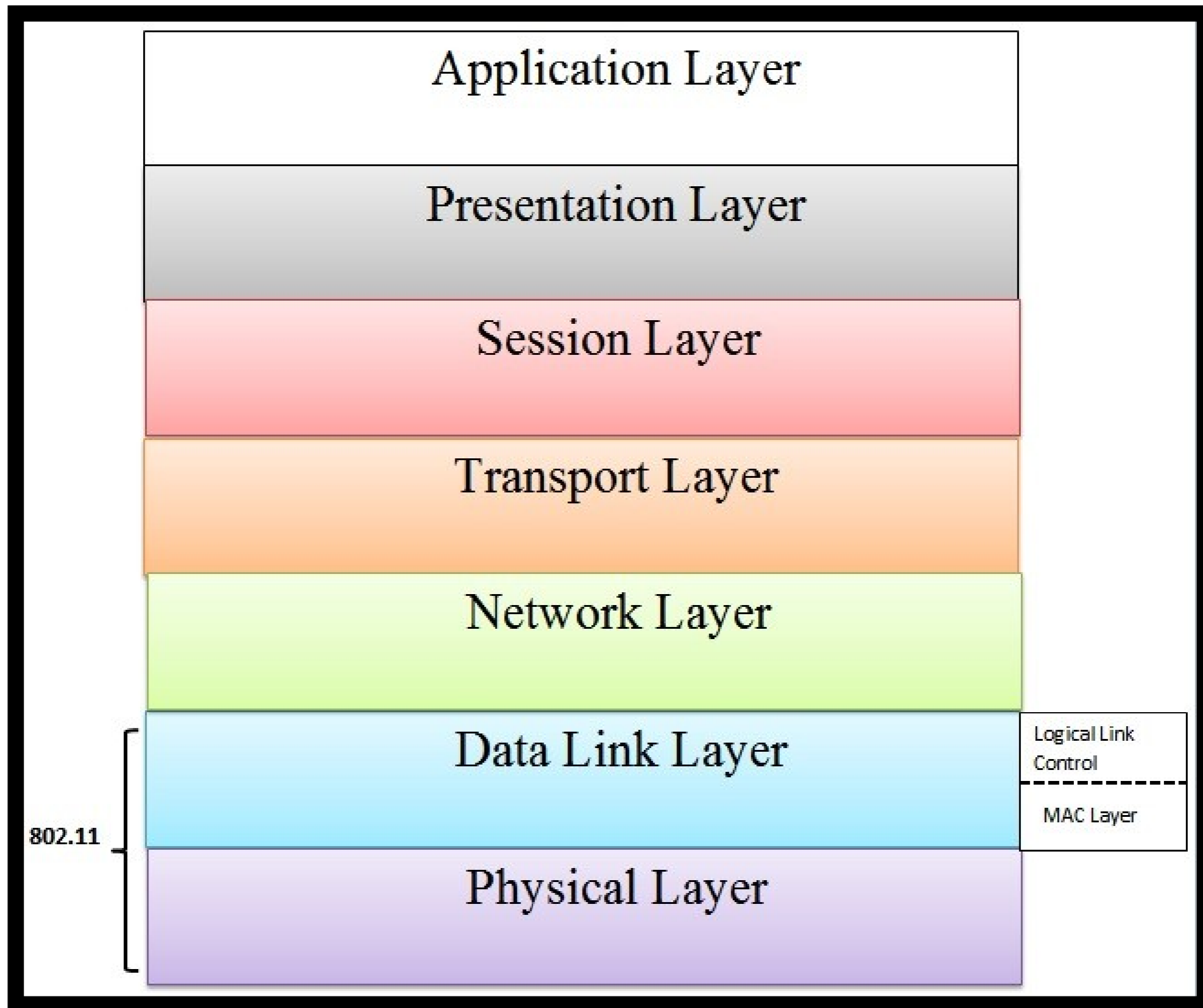

Layer 3 Packet inside Layer 2 Frame

- Frame gets changed out going from wired to wireless and wireless to wired

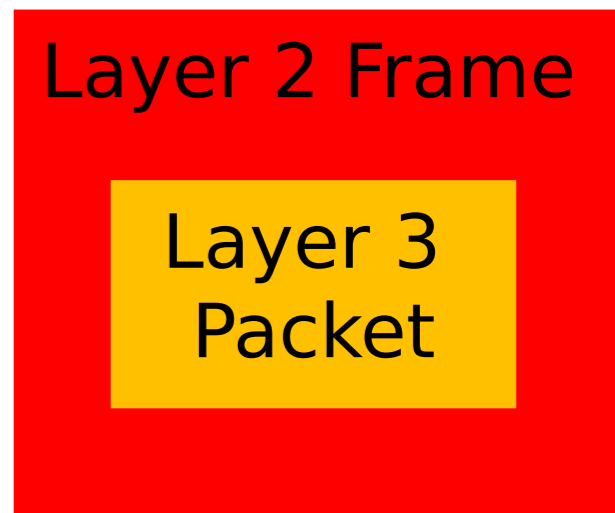
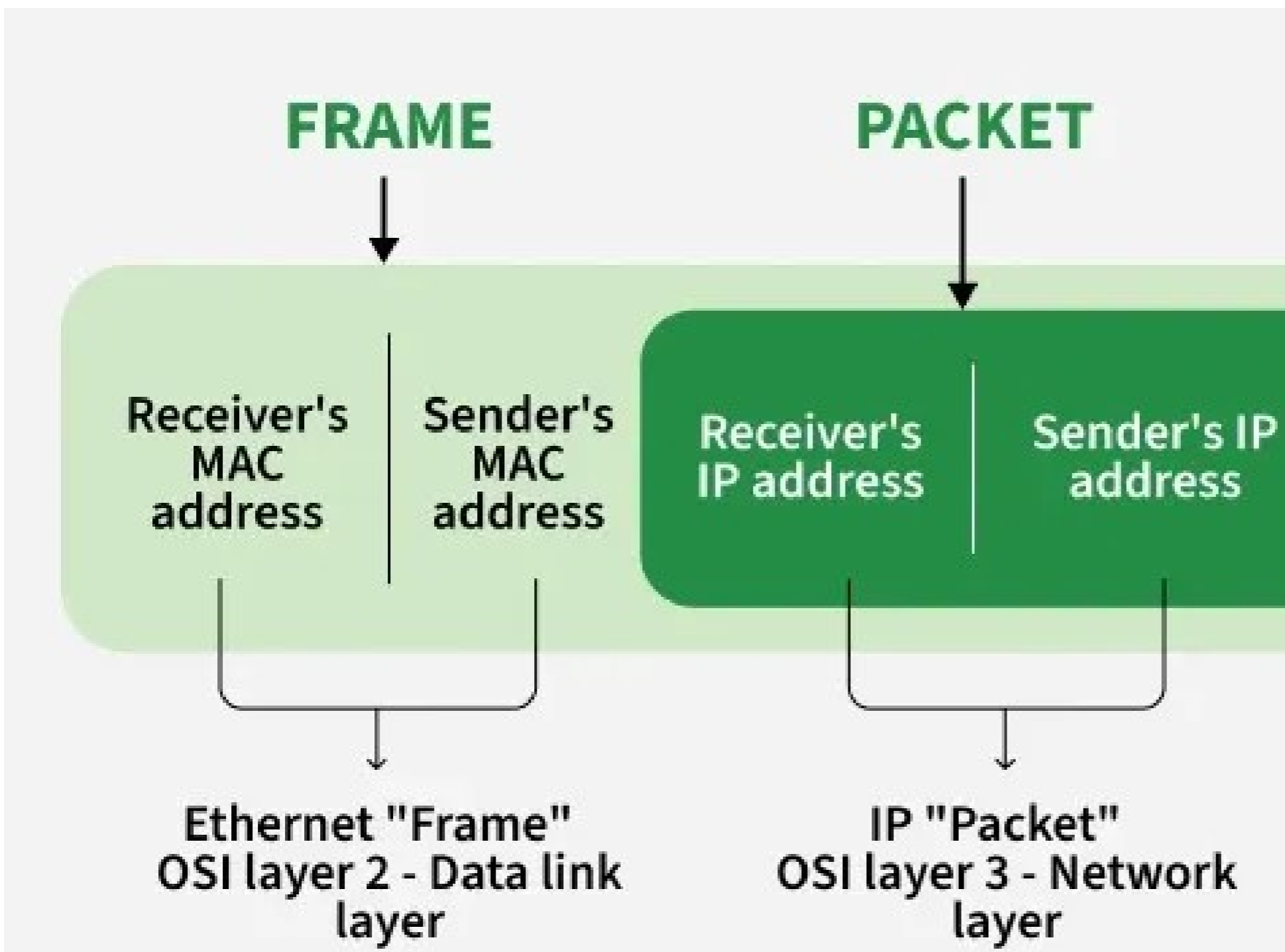

Layer 3 Packet inside Layer 2 Frame

- Frame gets changed out going from wired to wireless and wireless to wired

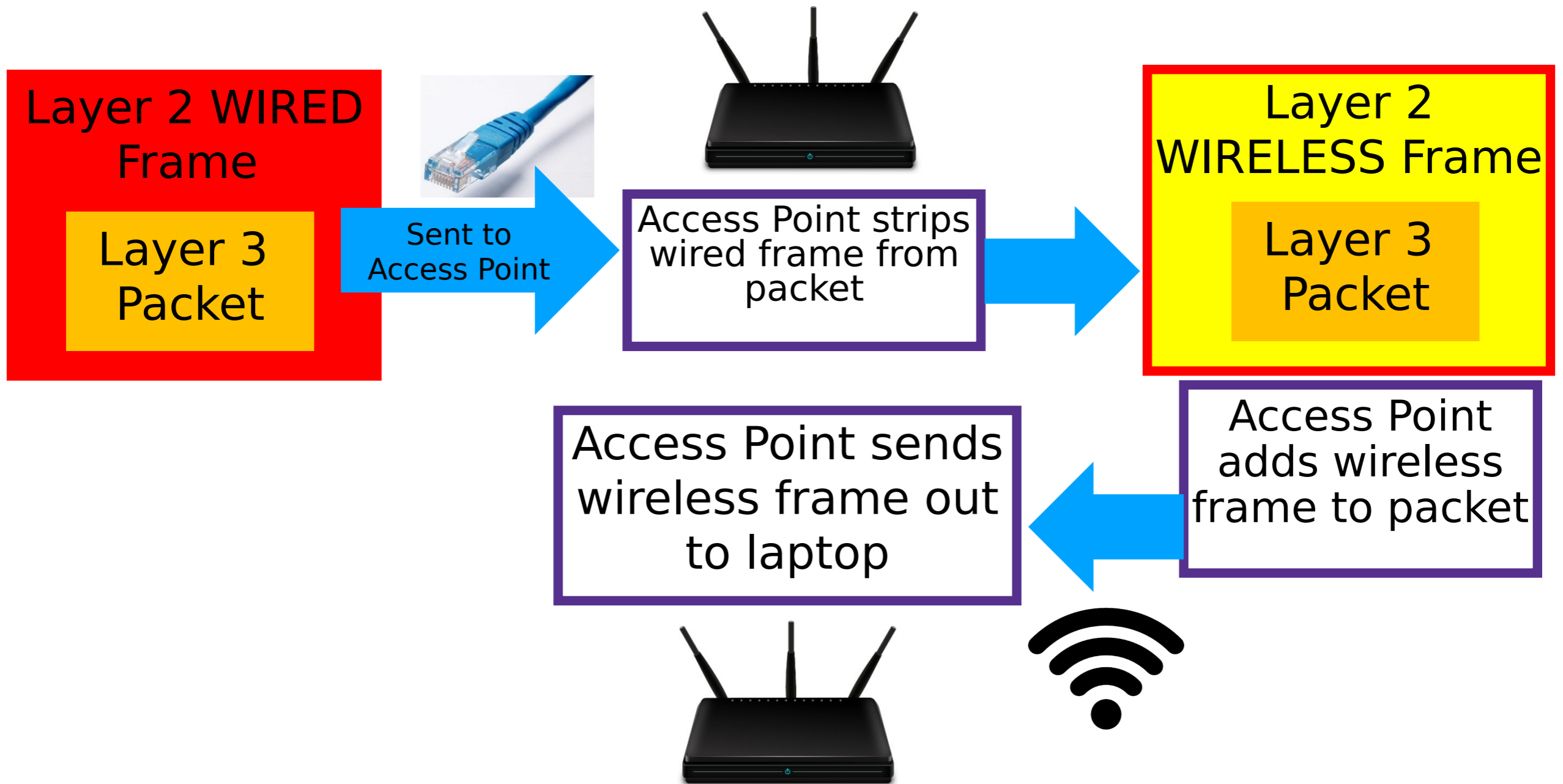

Process of placing the packet inside the Layer 2 frame is known as encapsulation

Wireless NIC need to connect to Wifi network



Can connect server with TWO network connections

- Good for connectivity redundancy
- If one fails the 2nd one can be used
- More redundancy = more availability

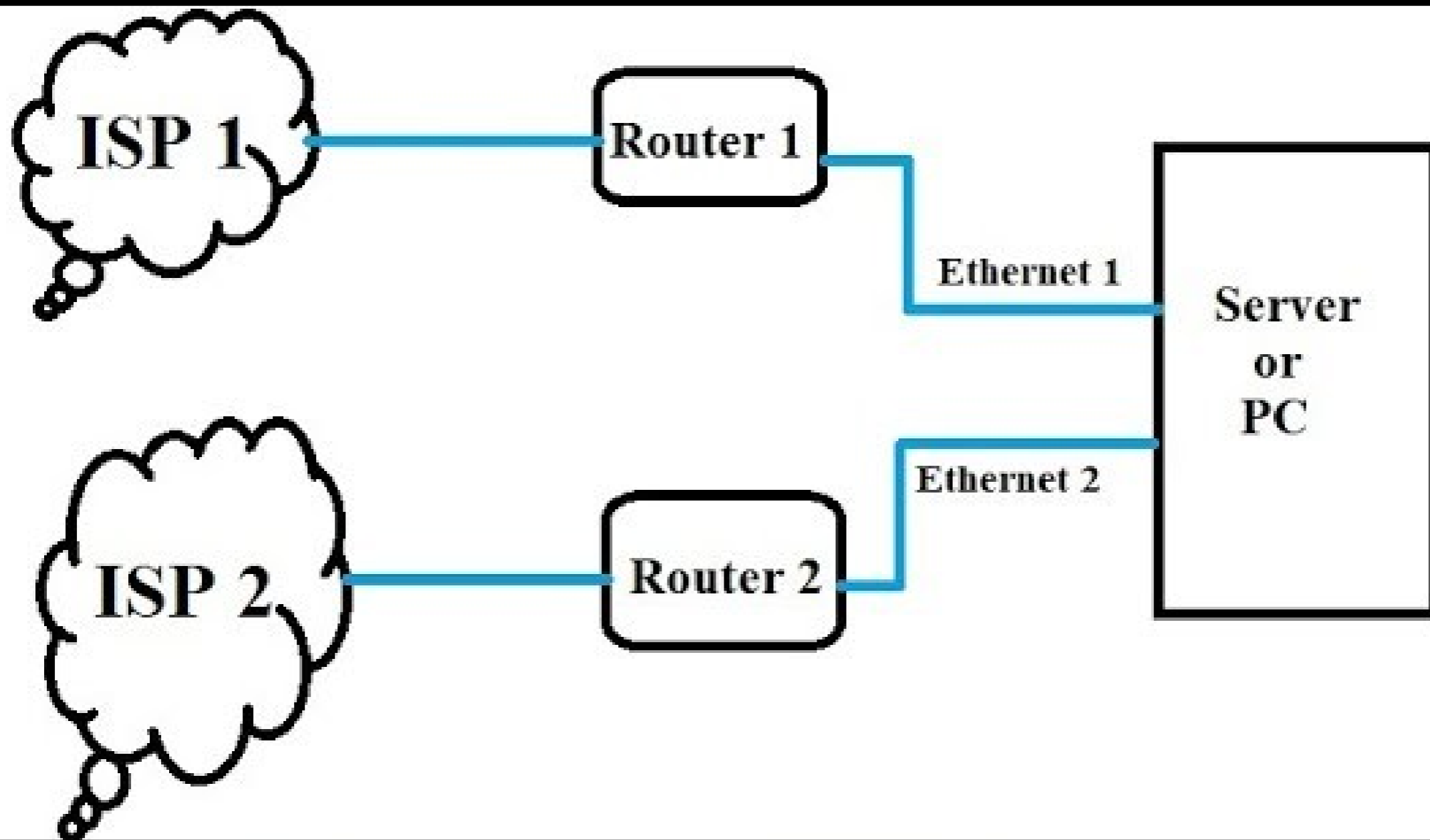

- NYSE has 3 data centers
- Primary in NJ (Mahwah)
 - Backup #1 in Secaucus
 - Backup #2 in Chicago

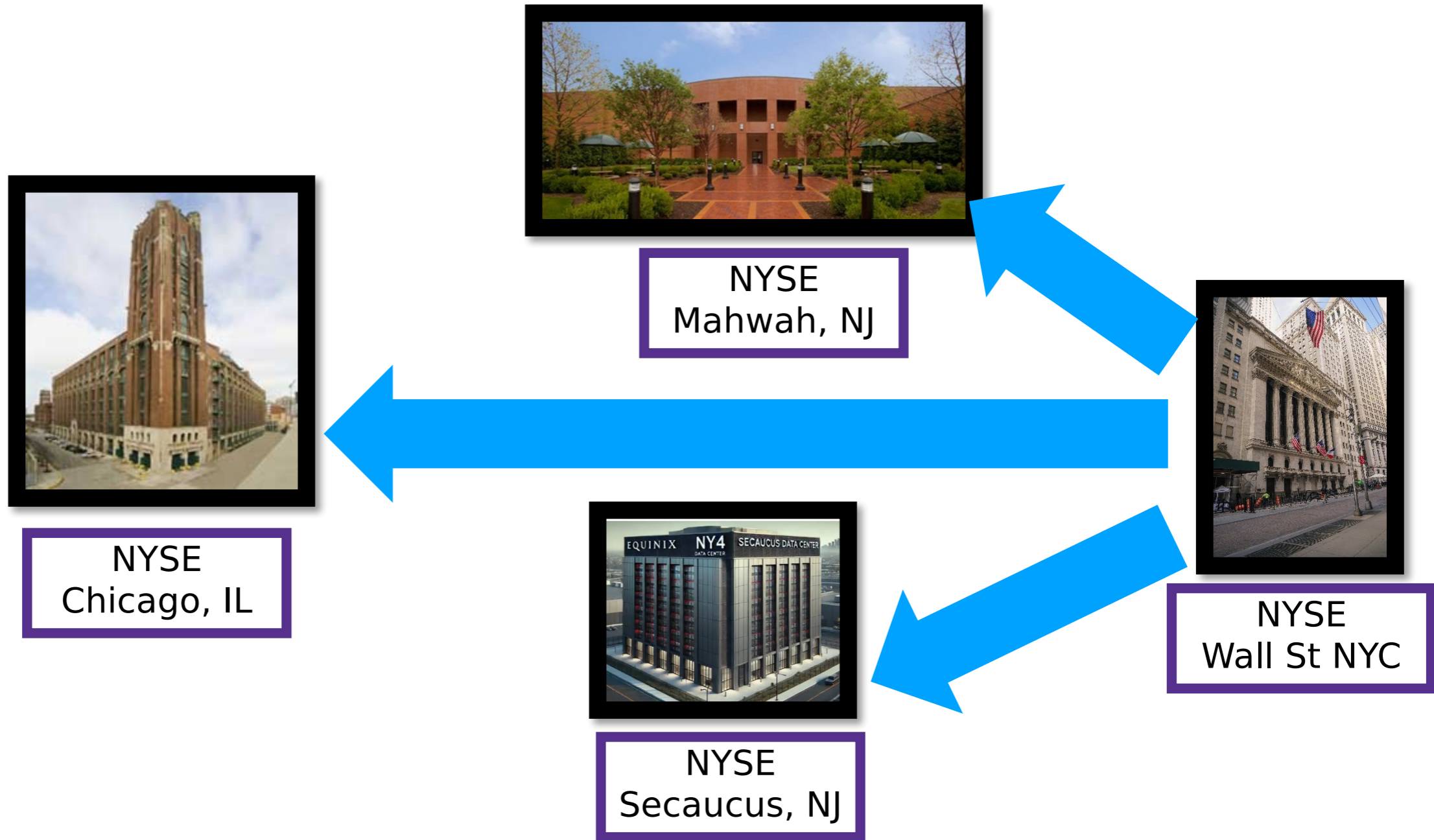

- Router: motherboard with 24 NIC cards
- Each NIC card has a different MAC and IP address

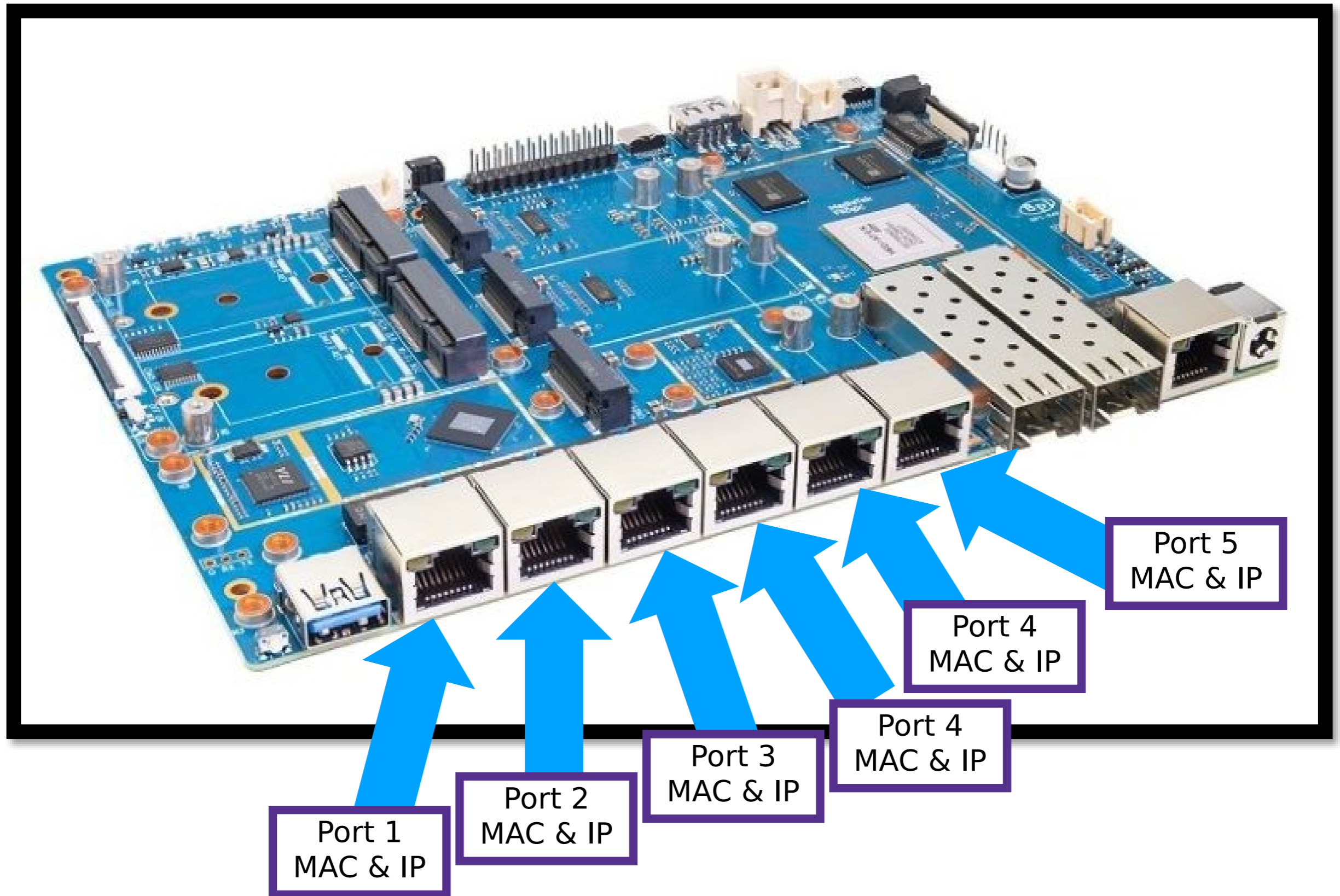

Laptop: 2 NICs: Wifi and Wired

- Each has its own IP address

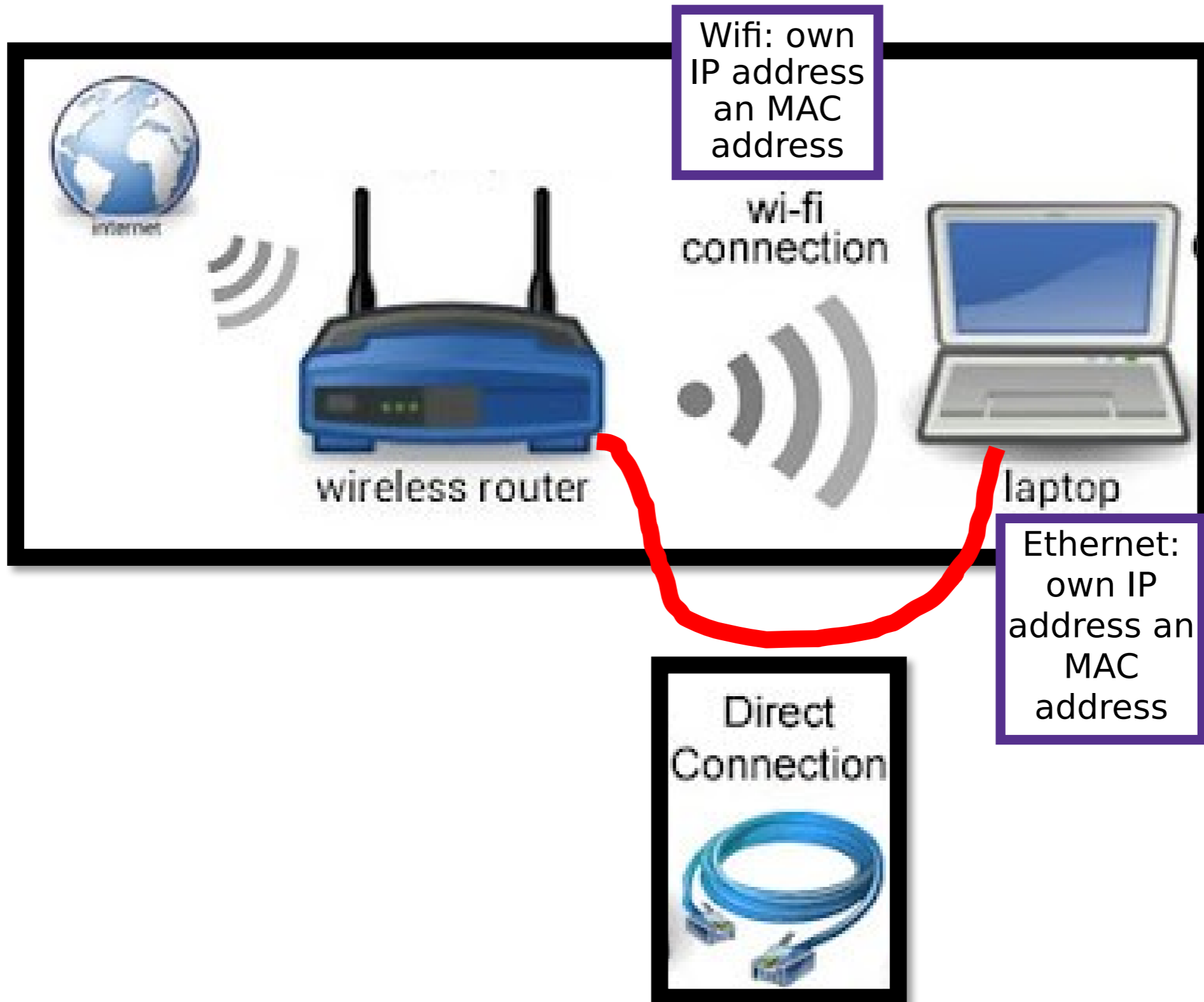

802.11 is the Wifi Standard
- Sine waves measured in frequency
- Hz is cycles per second

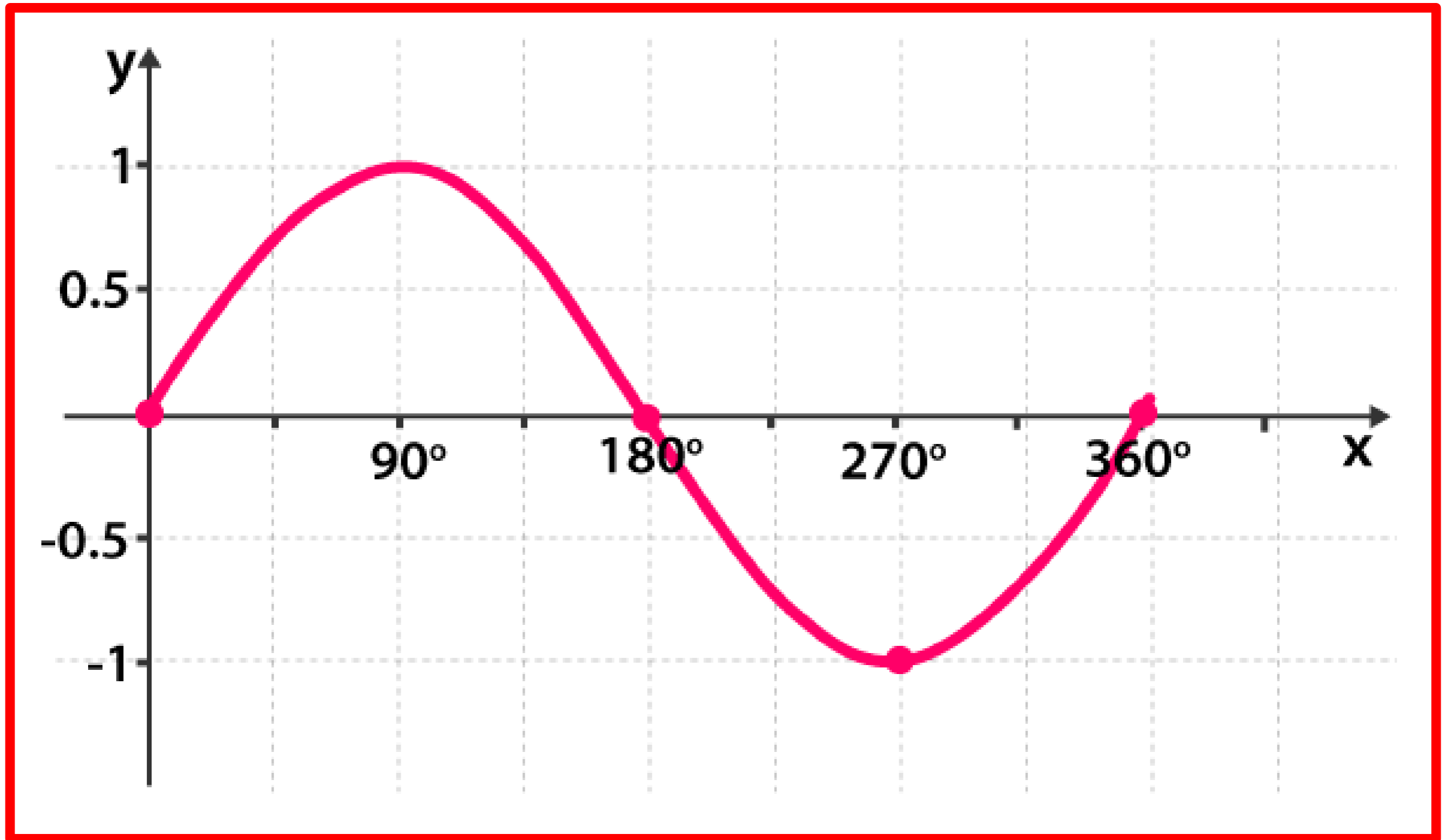

Wifi is 2.4 Ghz > communicates on same frequency as WAP

3 Cycles Per Second
- 1 cycle every 1/3 of a second

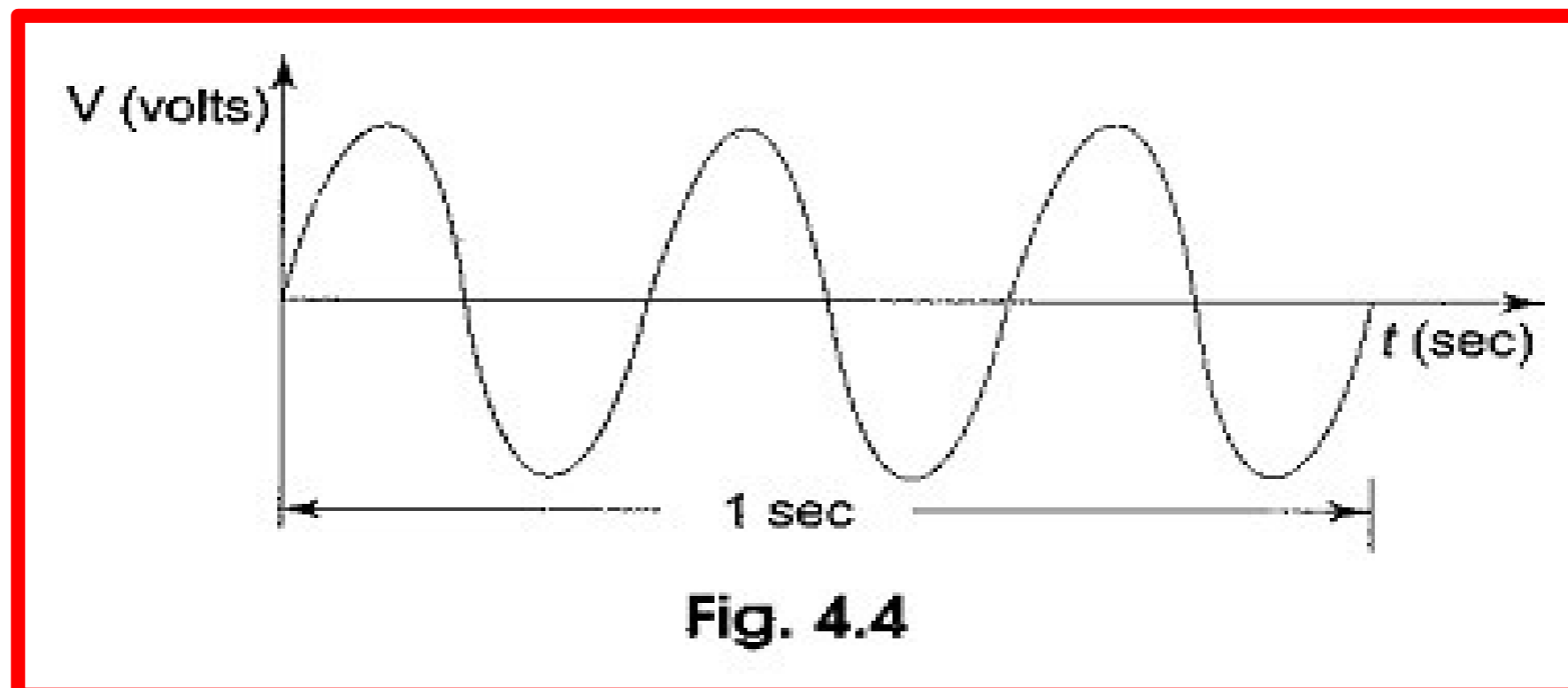
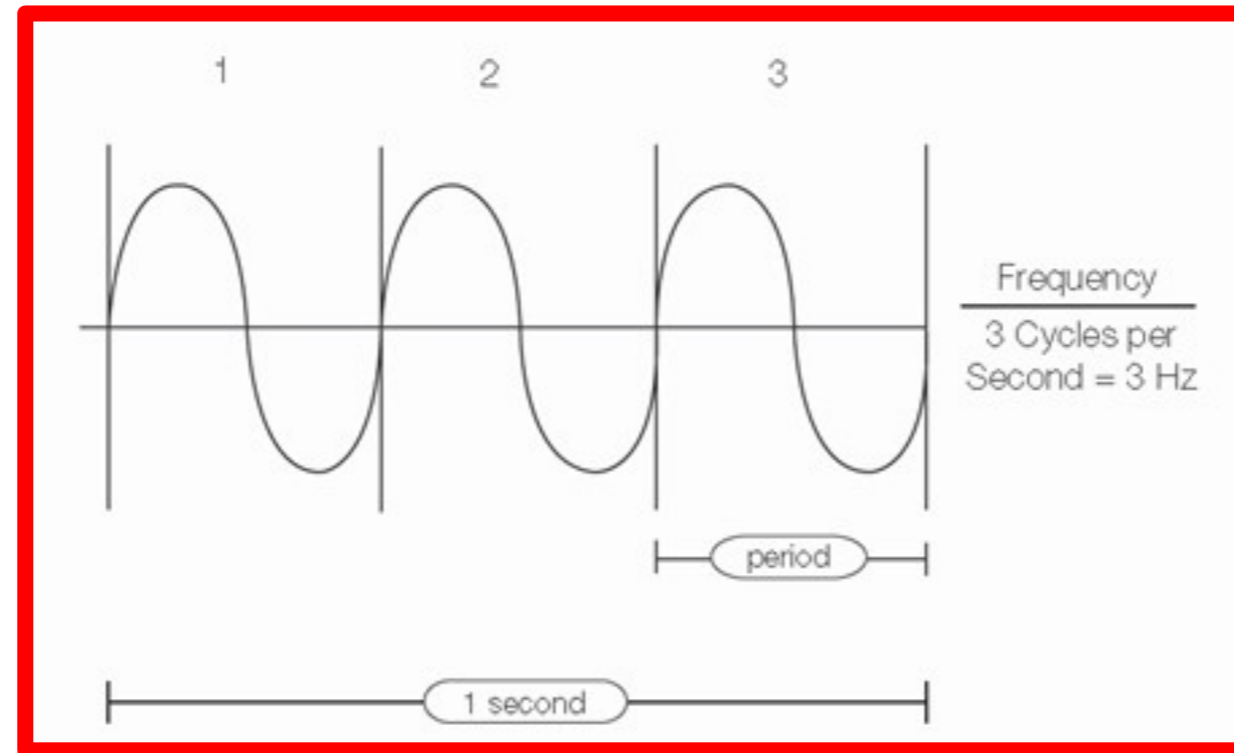

- 6 Cycles Per Second
- 1 cycle every $1/6$ of a second
 - Increase in frequency

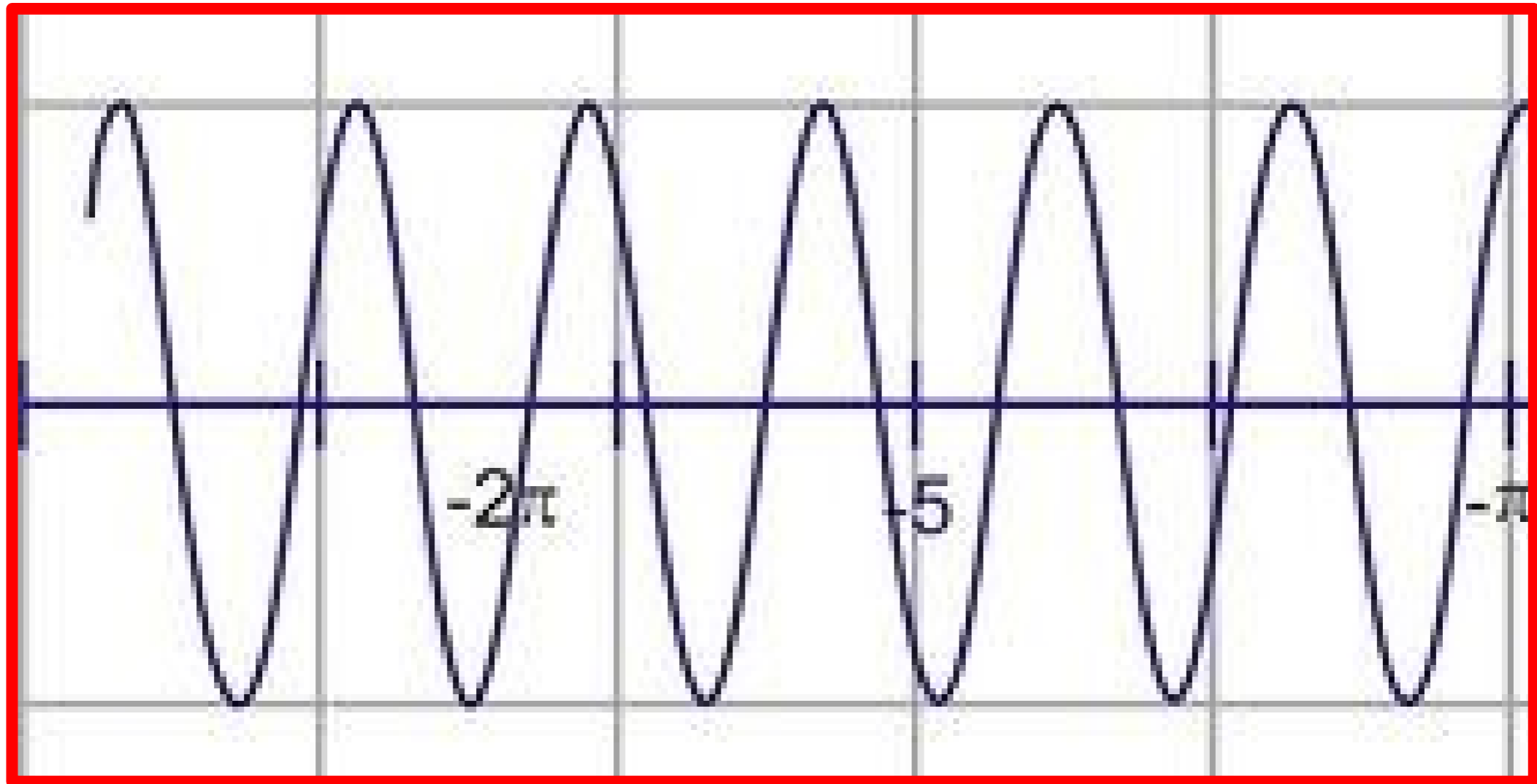

Frequency Spectrum

- Broken into service bands

- Service bands broken into channels, ie: radio stations 95.5

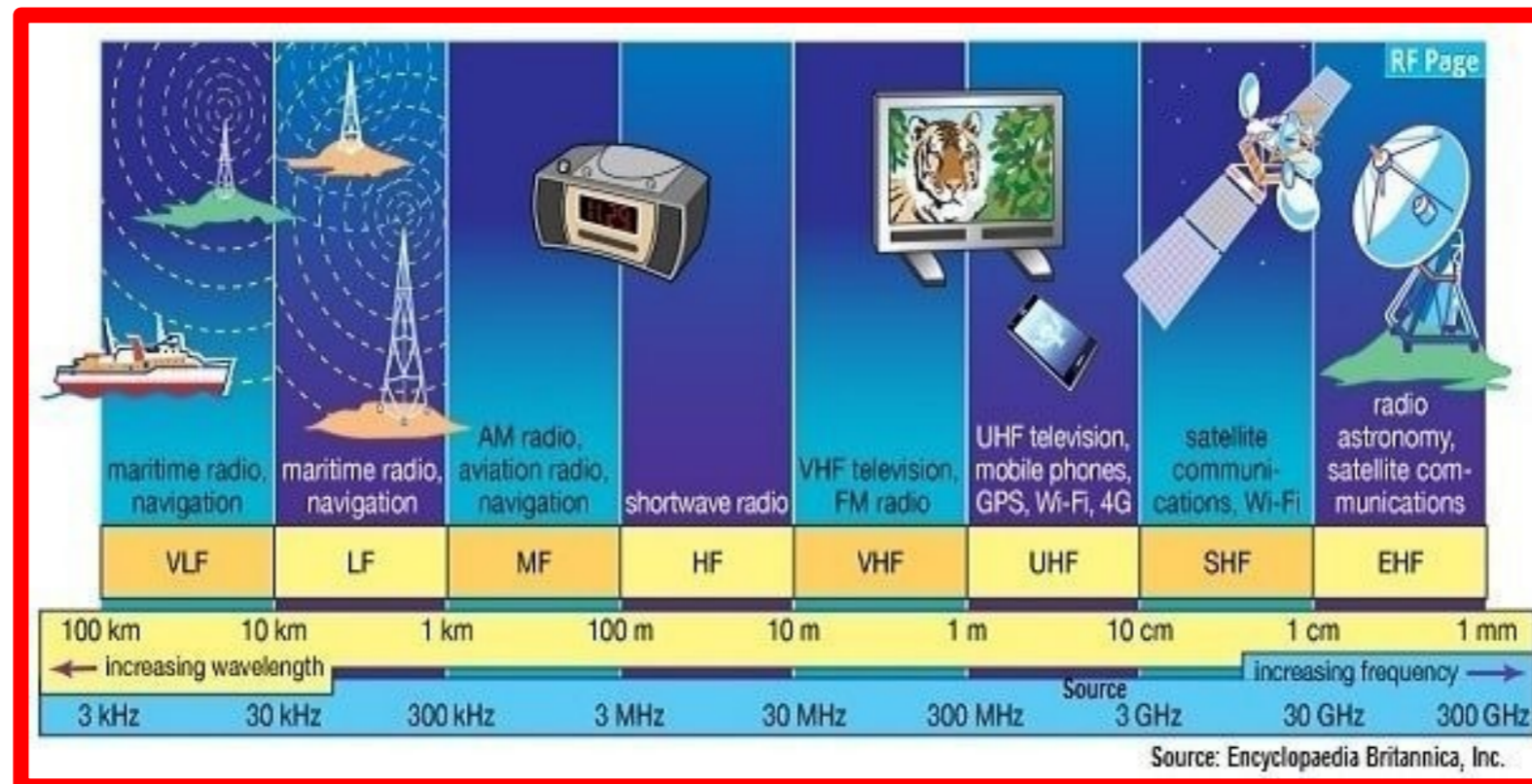
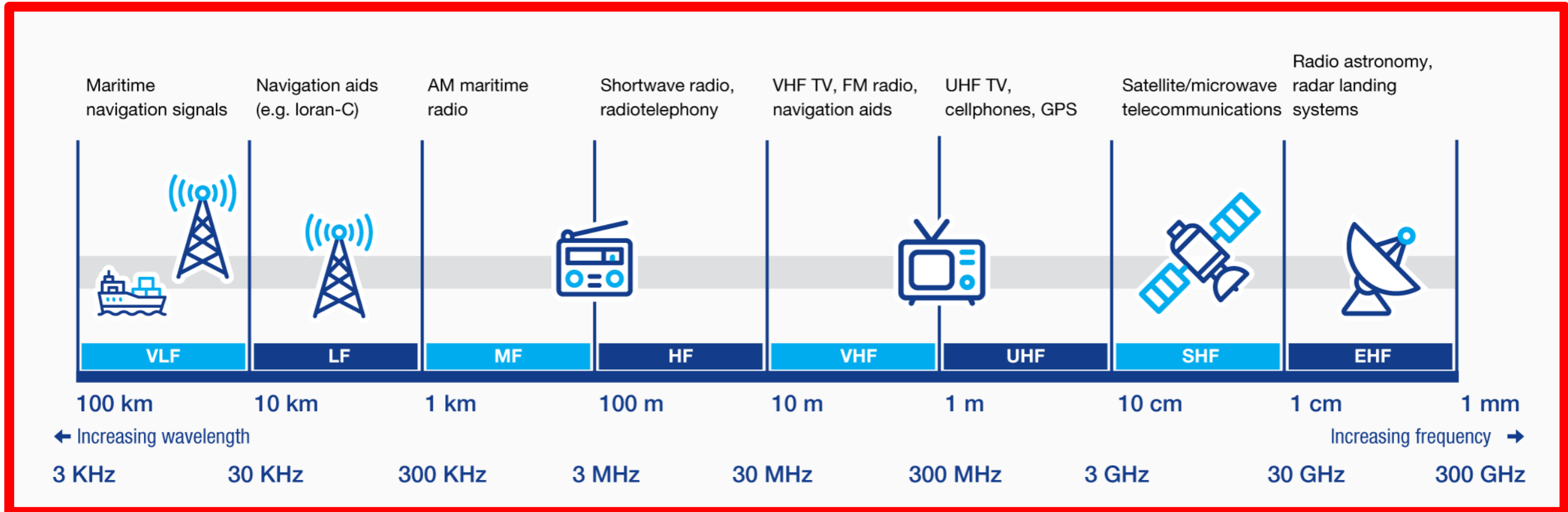

Wifi has 11 channels

- 2.4 GHz between 2.412 to 2.462
- Service bands broken into channels, ie: radio stations 95.5

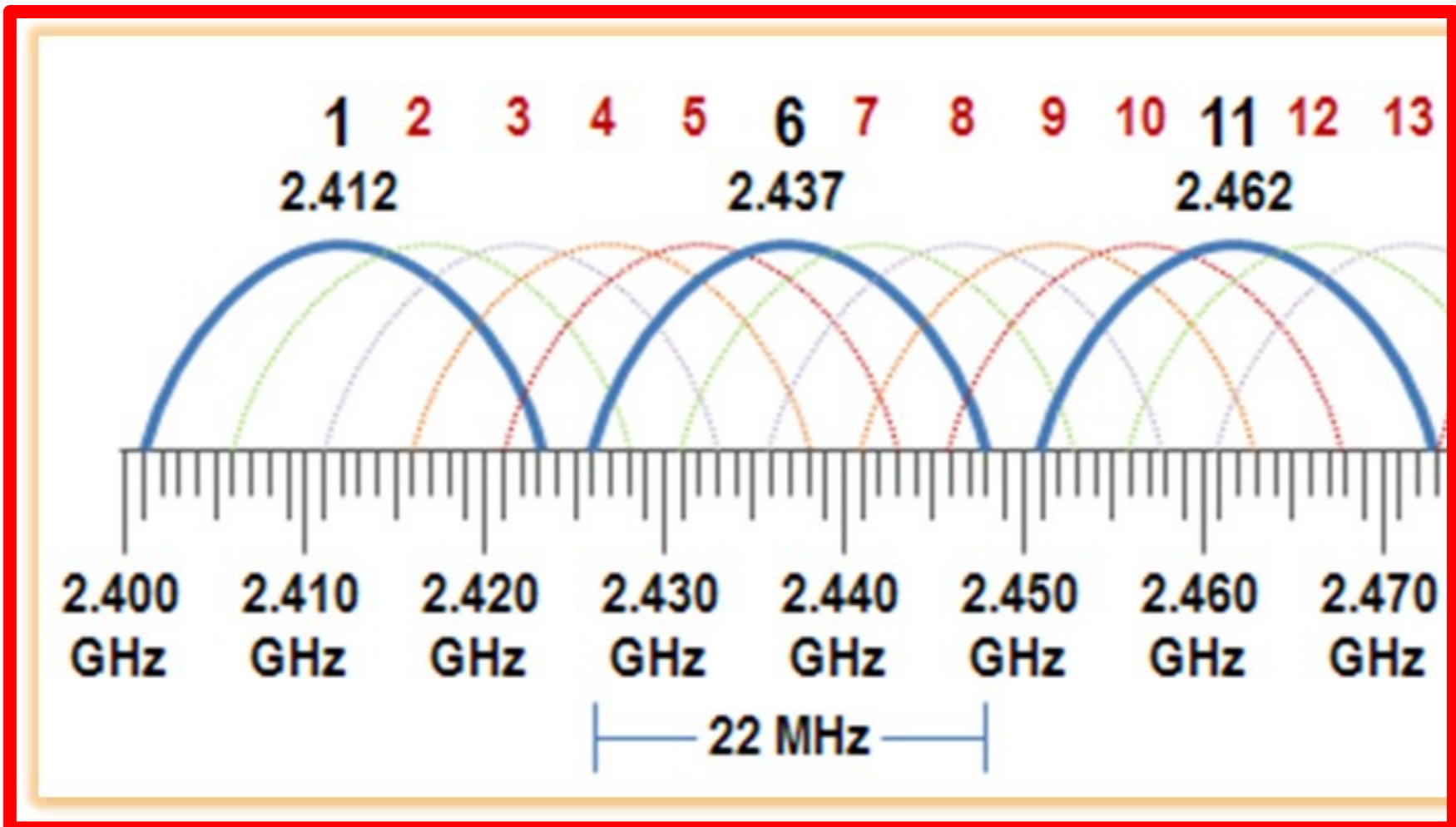
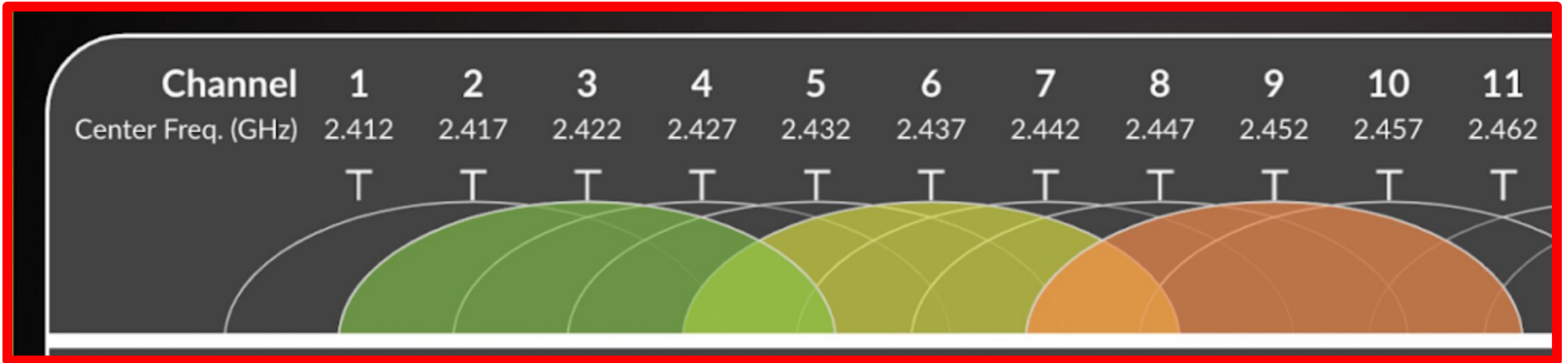

Radio Station has range of frequencies

- Radio station: 100.3

- Range is 100.25 to 100.35

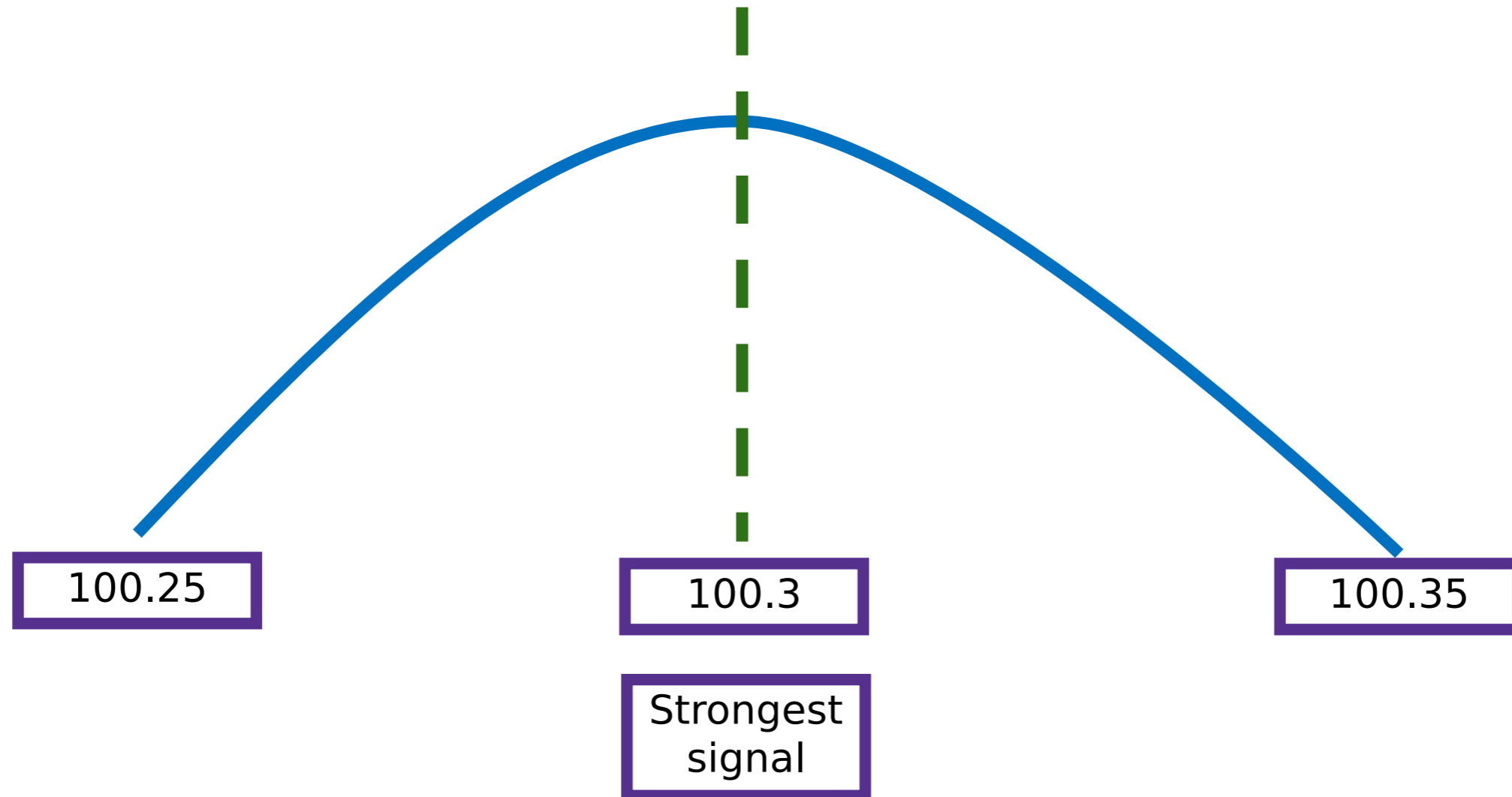

- Licensed Spectrum are government controlled
- ie: radio station
 - 2.4 Ghz and 5 Ghz: can broadcast without license

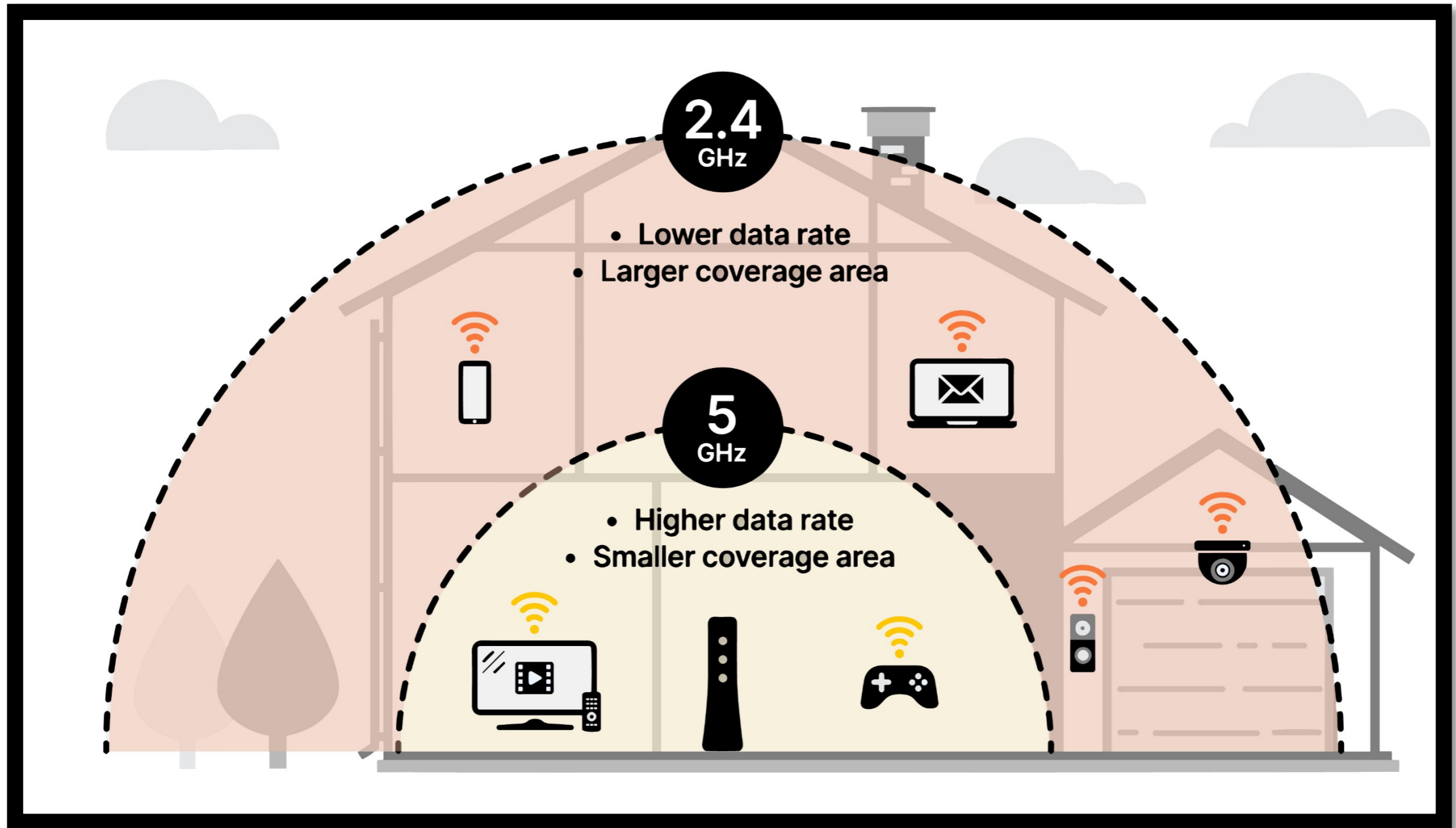

2.4 Ghz spectrum

- Best channels to use are 1, 6 and 11
- 1, 6, 11 do not overlap/interfere with each other
- 3 non-overlapping channels

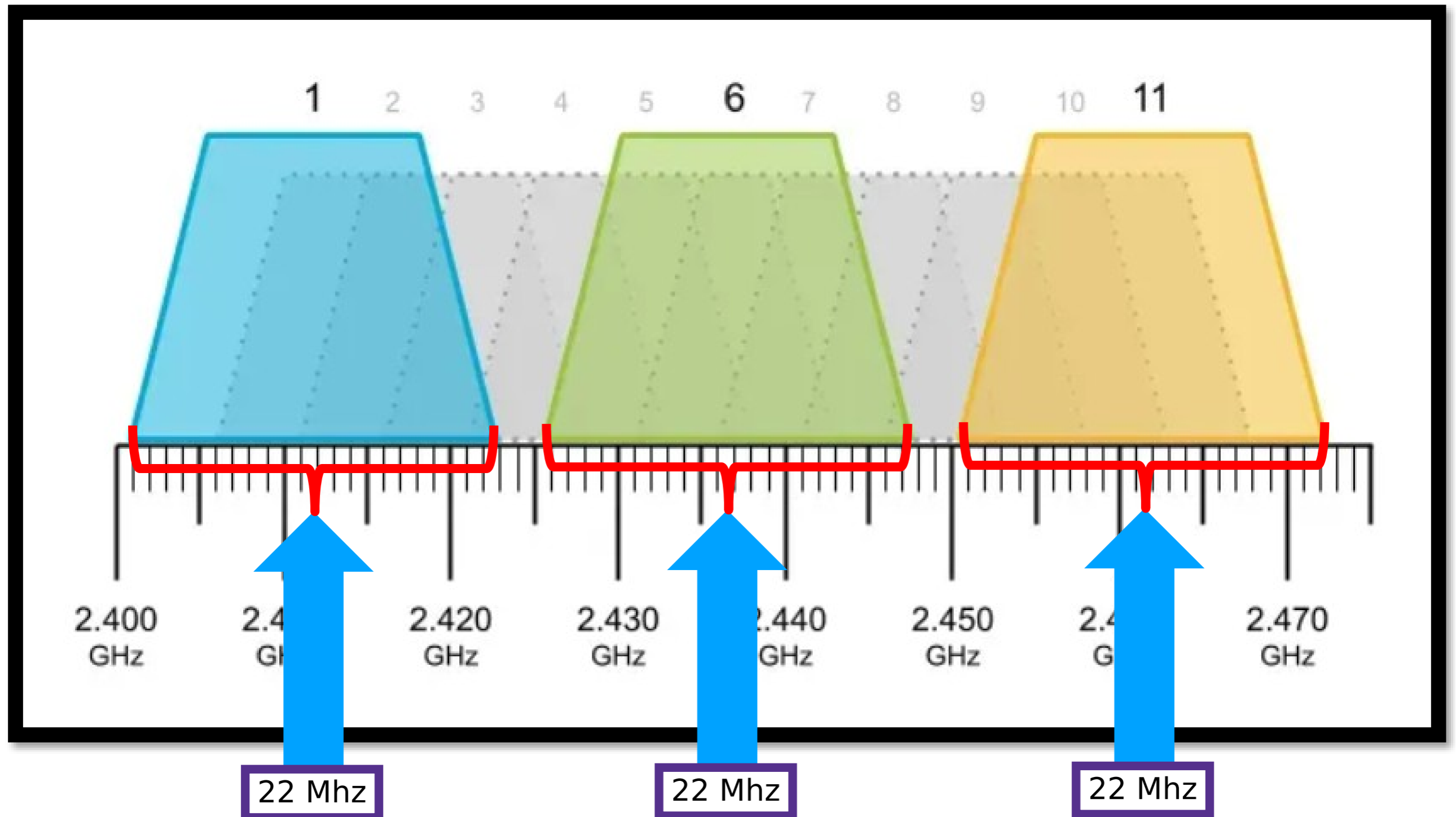

2.4 Ghz spectrum

- Different channels on the same floor to prevent interference

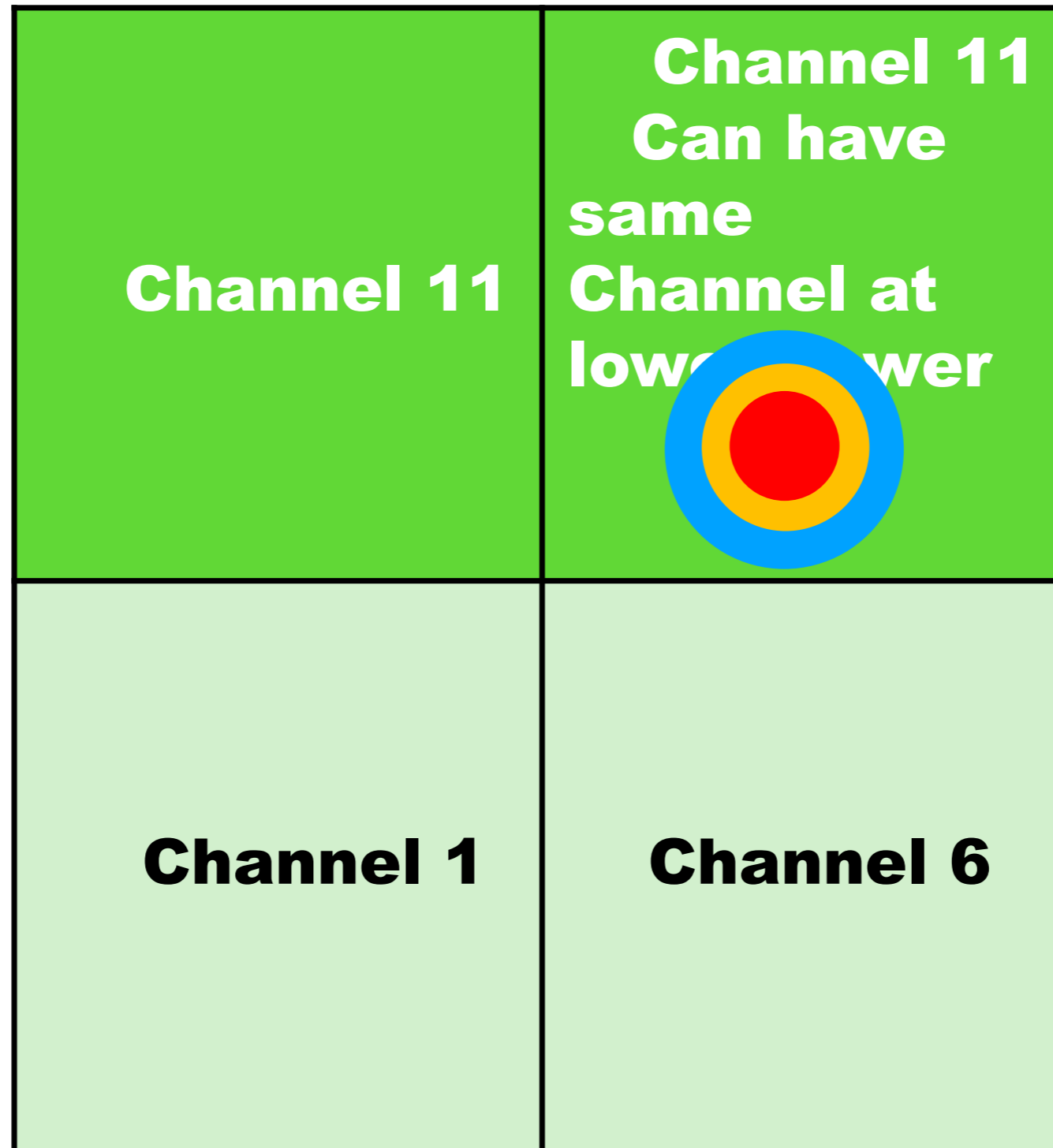

5 Ghz spectrum

- Increase bandwidth but reduced penetration through walls
- Increased speed



5GHz*

Pros:

- Faster speeds*
- Less prone to interference*
- Less congested*

Cons:

- Covers smaller areas*
- Cannot pass through objects*



- ## 2.4 Ghz spectrum
- Can pass through walls
 - Lower speed

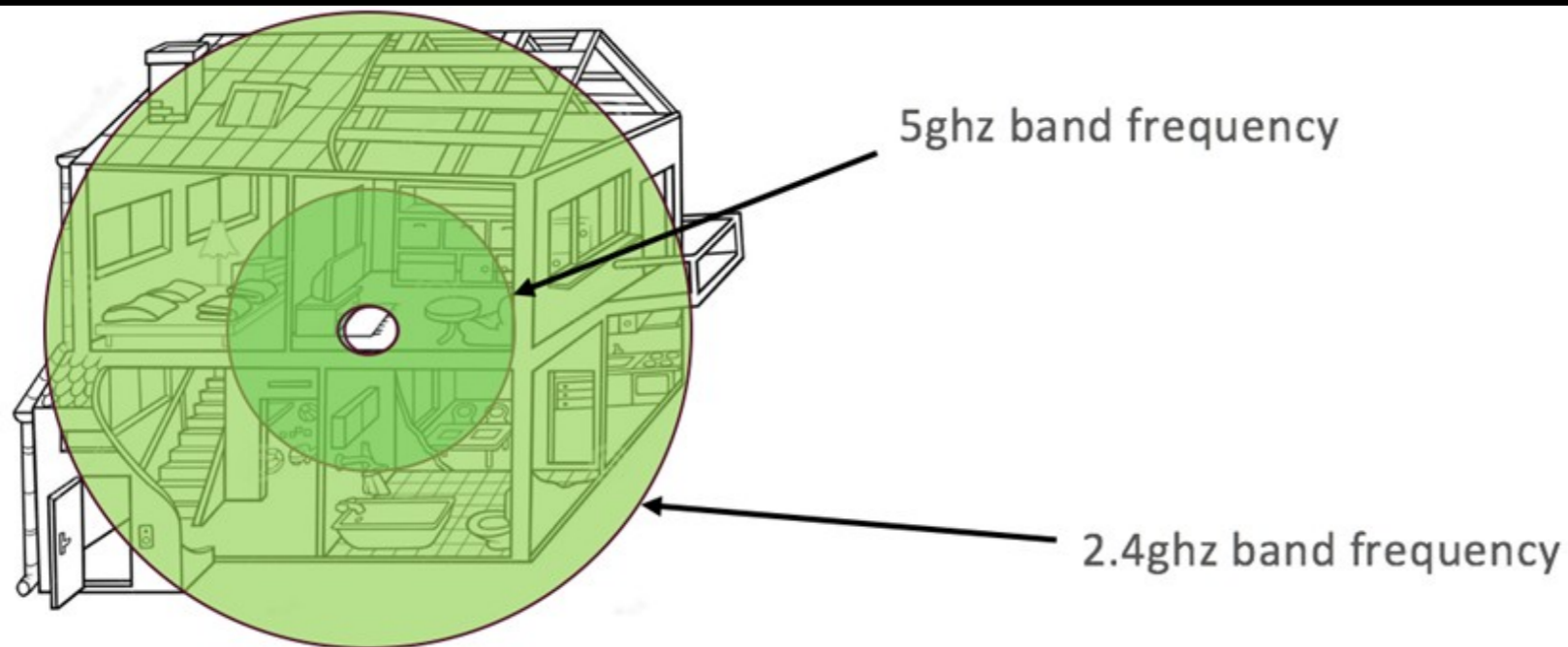

2,4 GHz



LONG RANGE, BUT SLOWER

- ✓ Longer range
- ✓ Good wall penetration
- ✗ Slower speeds
- ✗ More interference (crowded band)



The bottom section of the graphic shows a green wireless router on the left, a brick wall in the middle, and a laptop on the right. The laptop screen displays a signal strength indicator with four bars, and green curved lines represent the signal passing through the wall.

Wireless LAN (WLAN)

- Uses multiple Wireless Access Points (WAP)

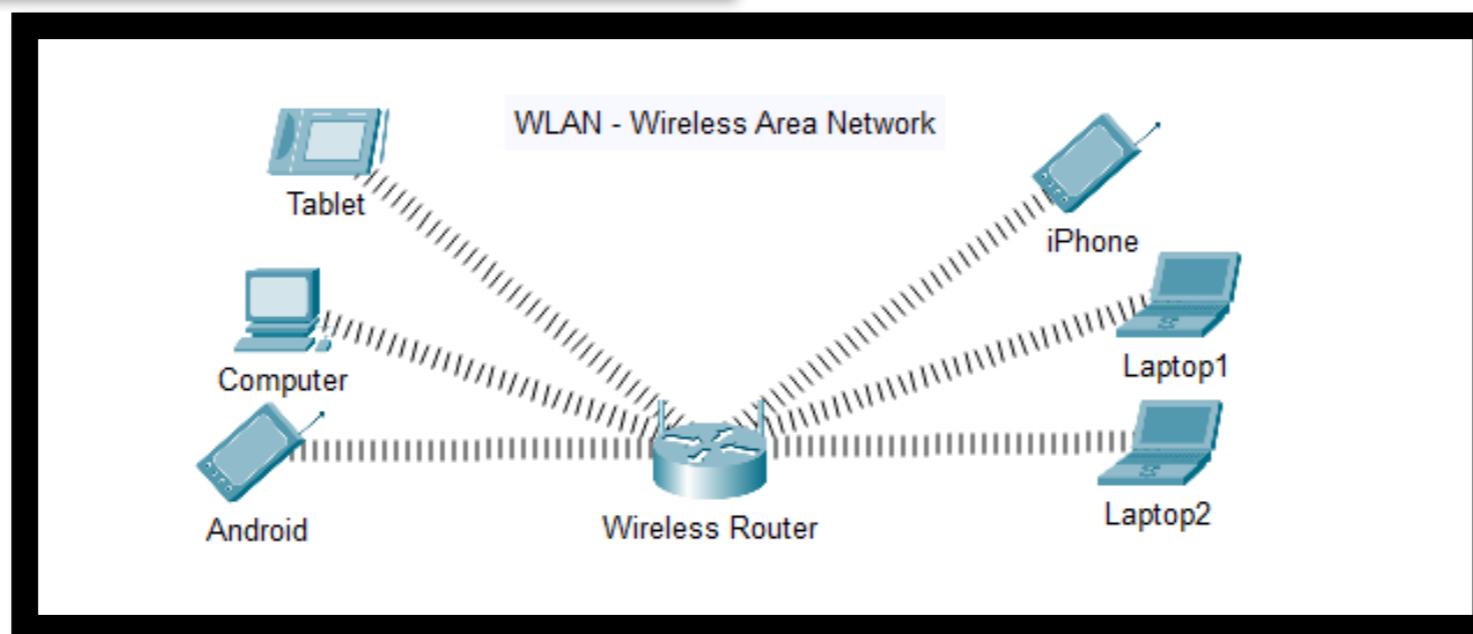
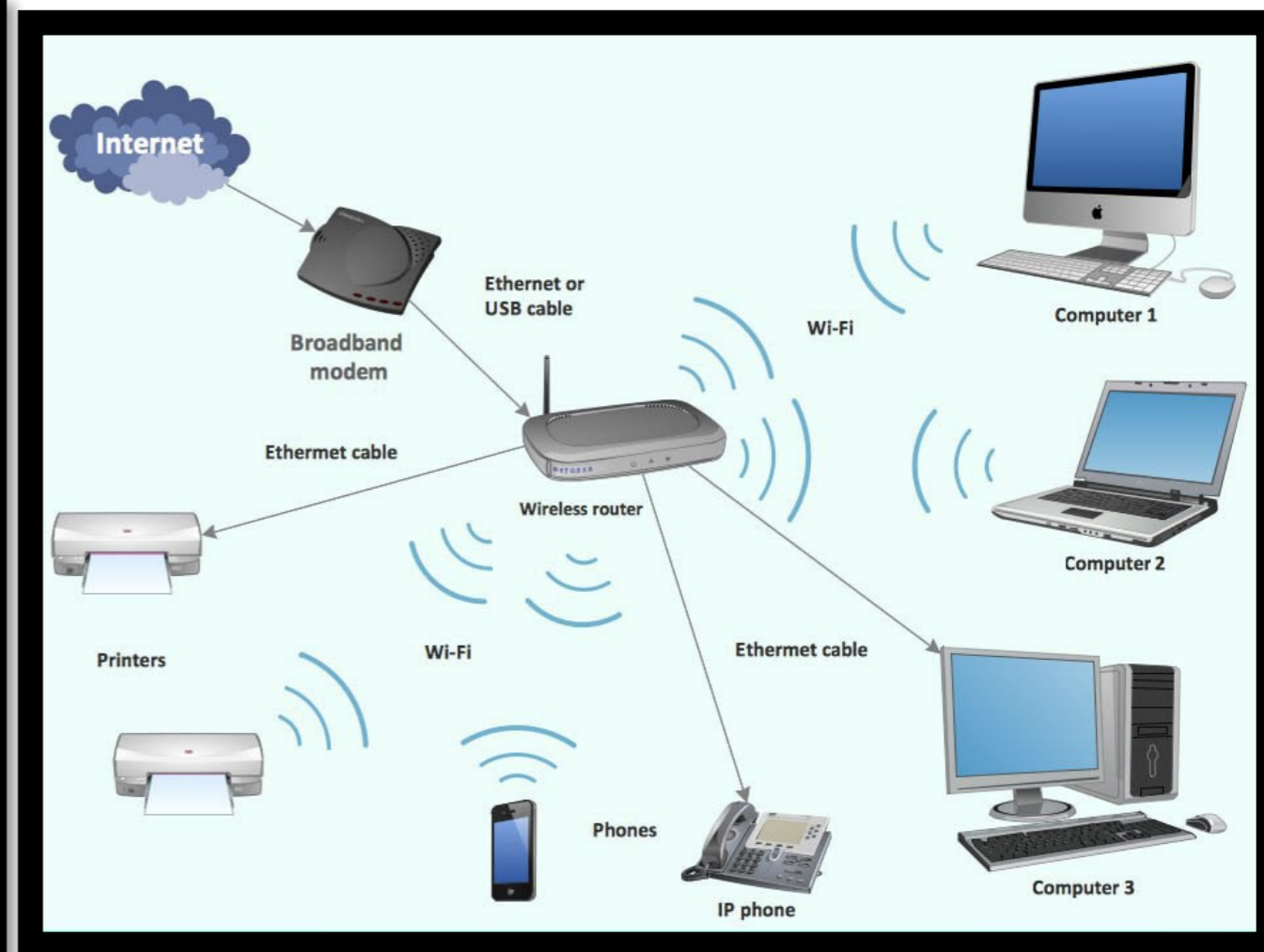
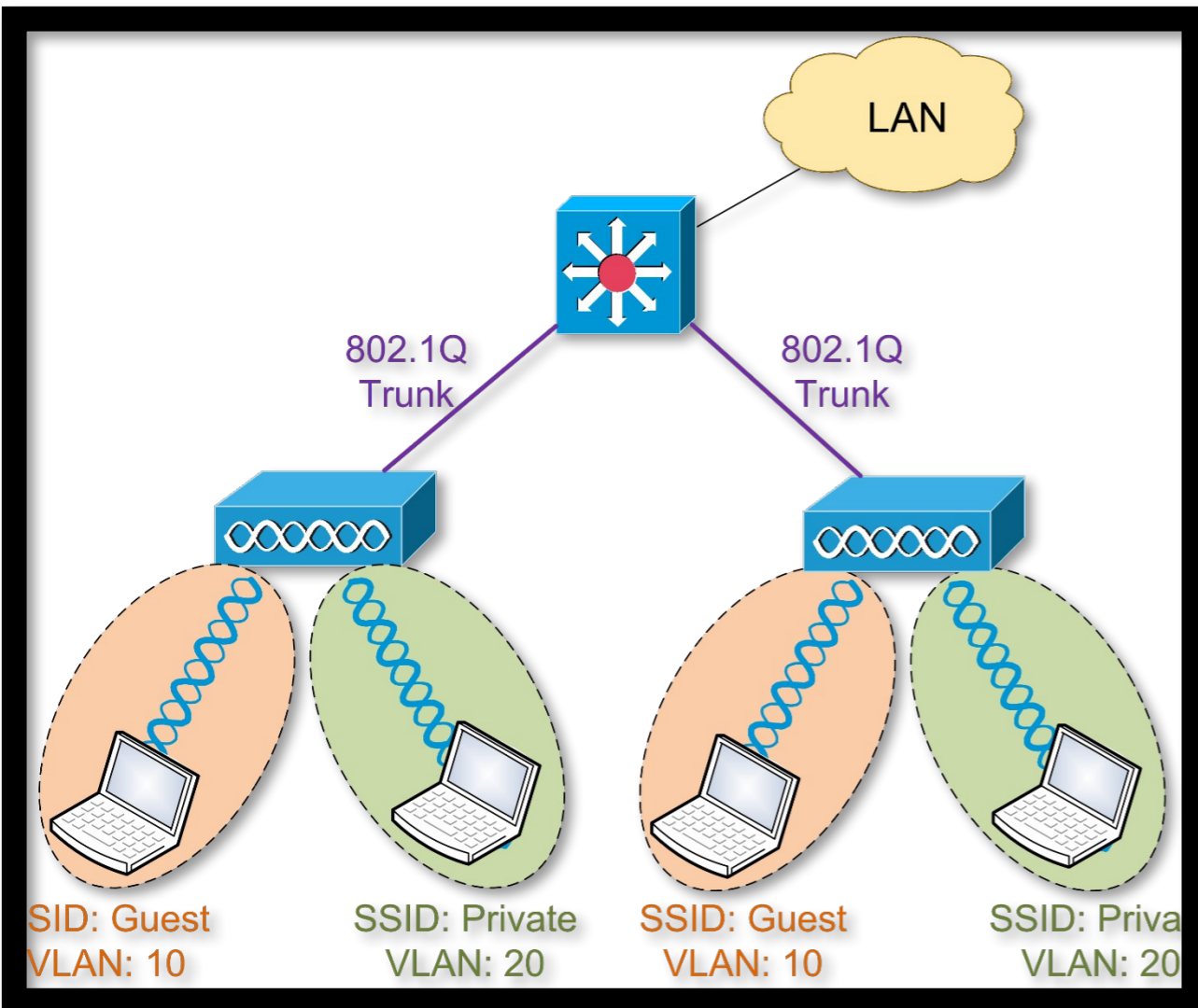

SSID: Service Set ID; identifies access point
BSS: Basic Service Set; WAP and all connections to WAP
ESS: Extended Service Set; group of BSS that use same SSID/password

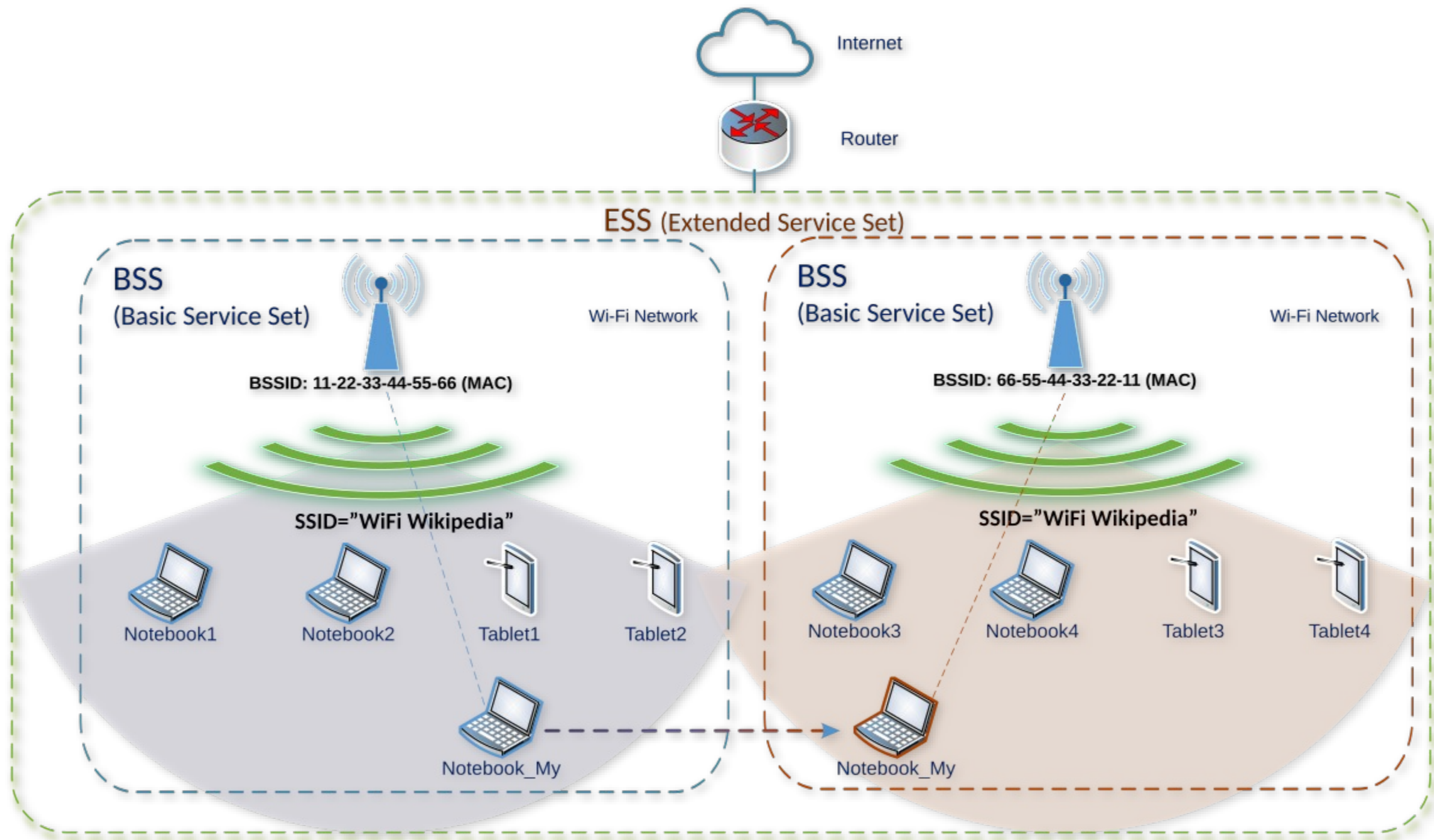

ESS: Extended Service Set; used for roaming

- Seamlessly connect and disconnect to WAPs on same network

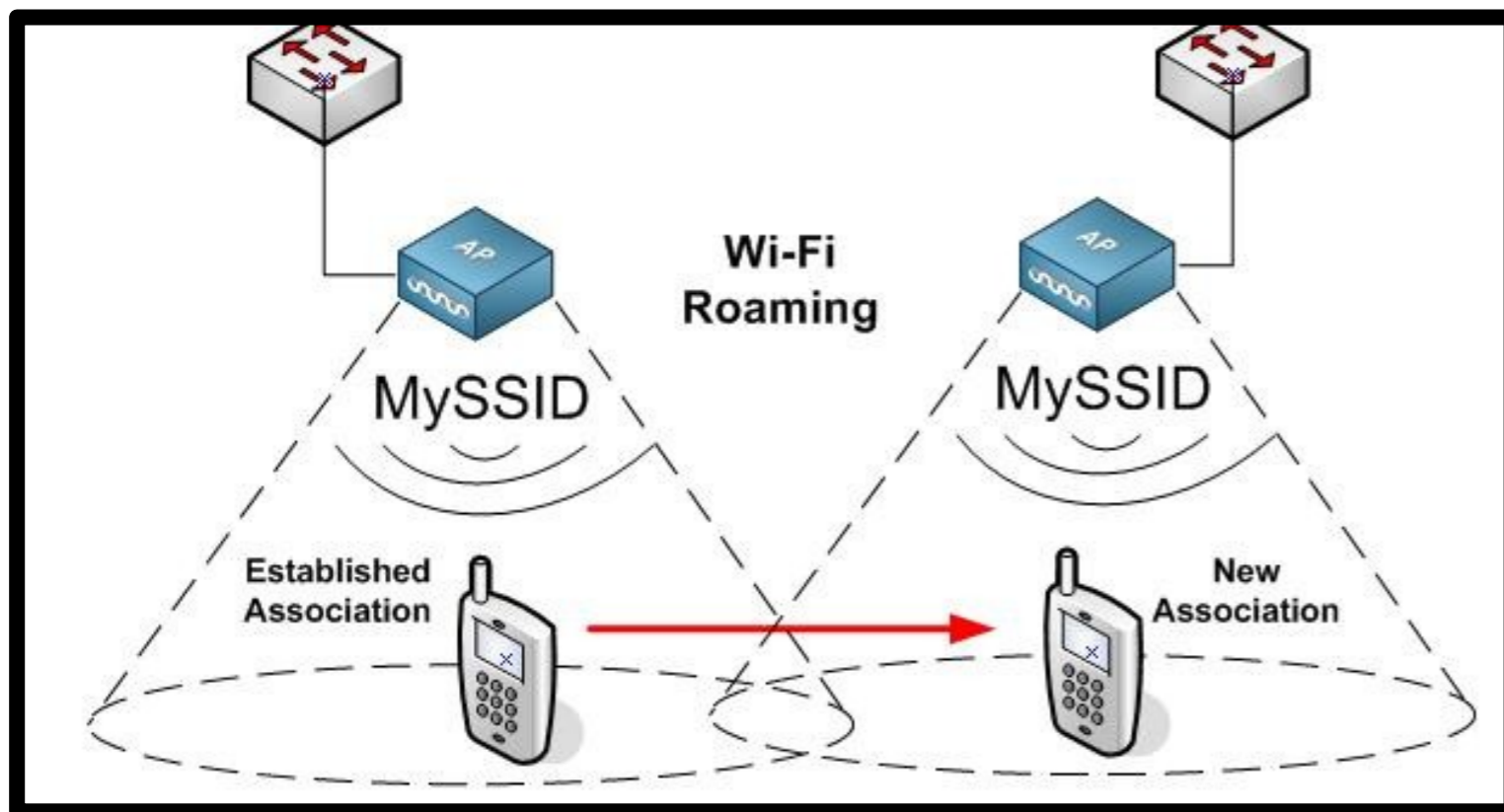
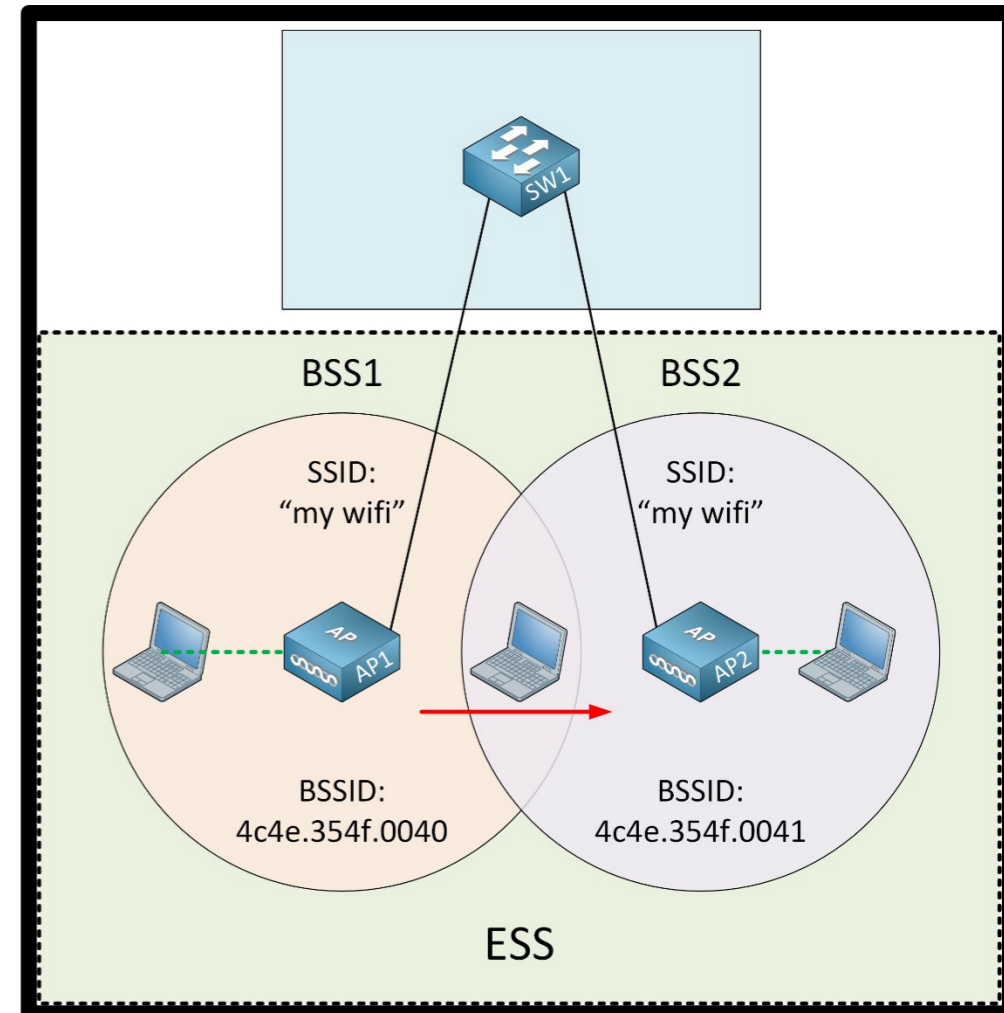
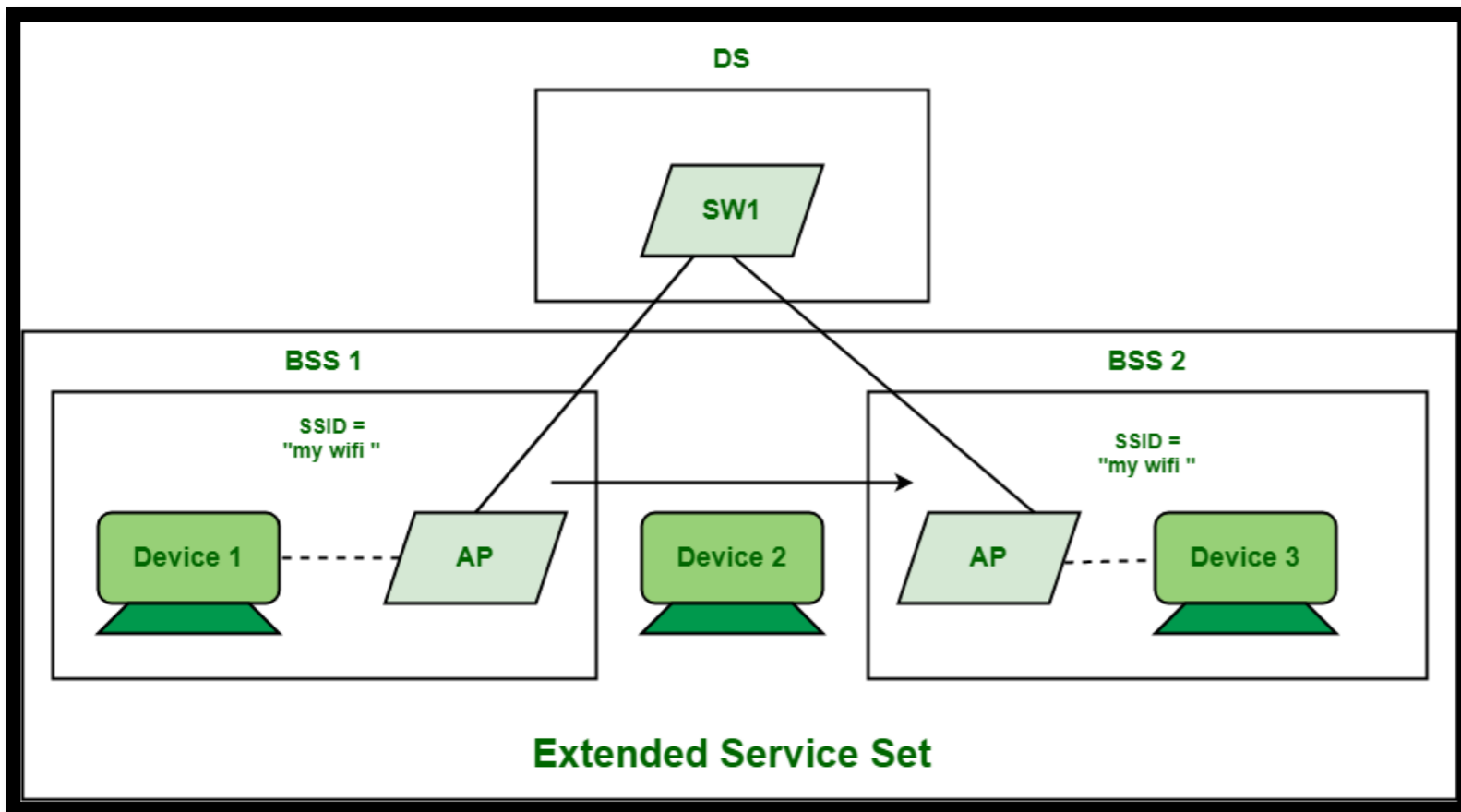

VPN: Virtual Private Network

- Extends private network over public network

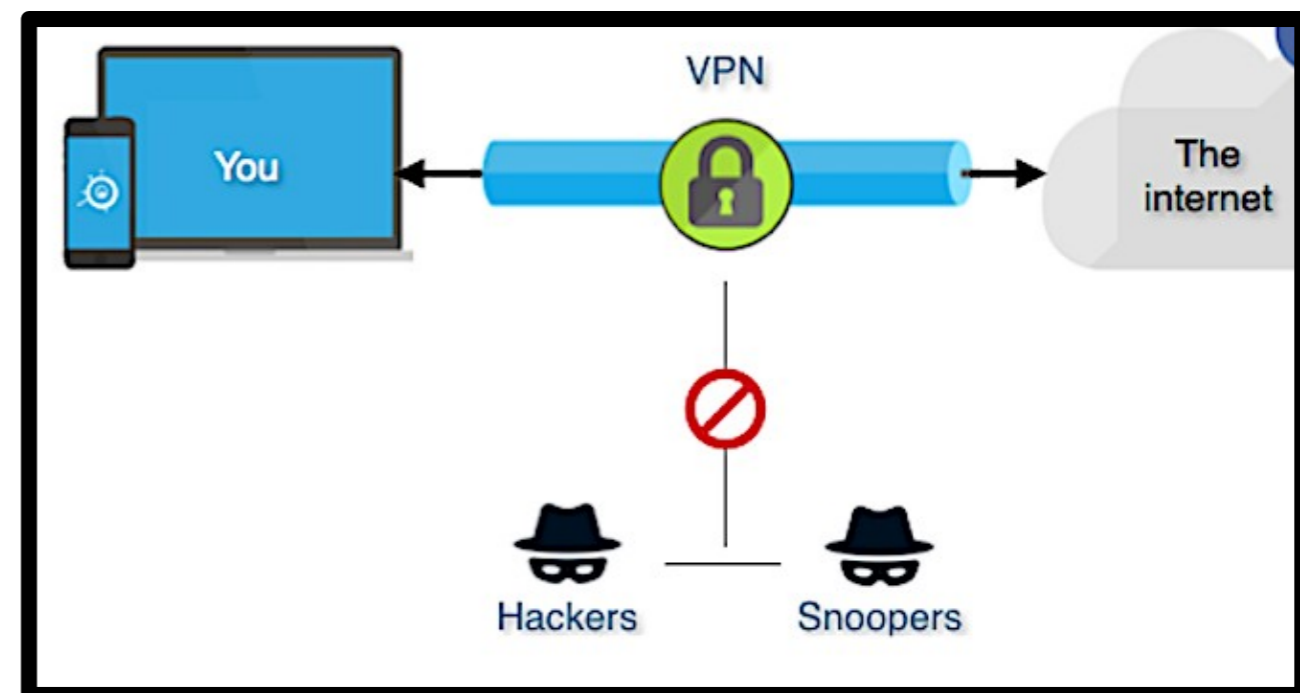
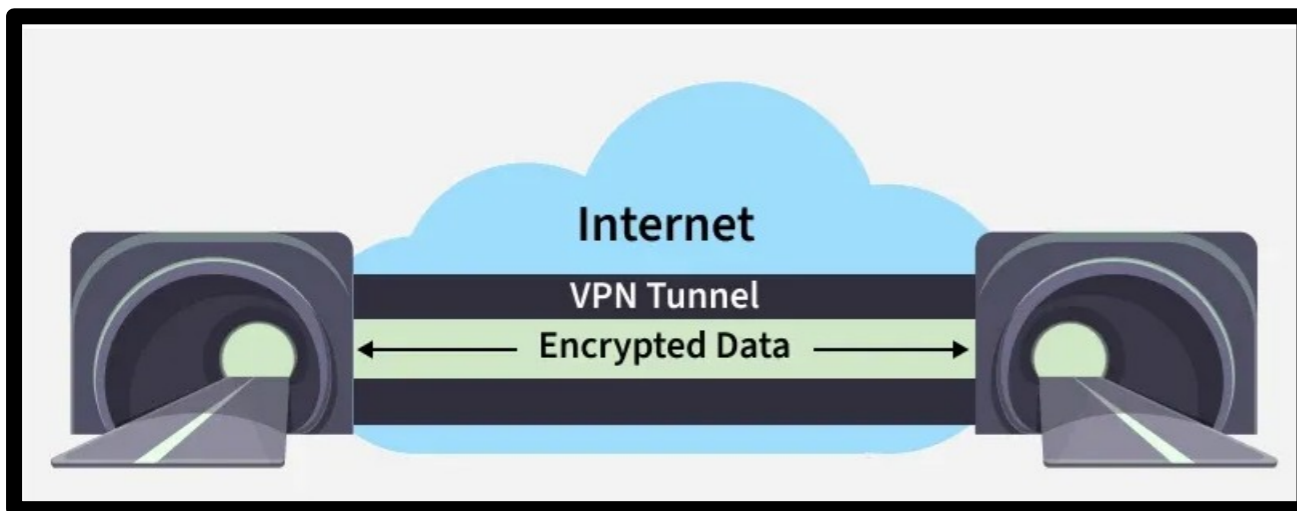
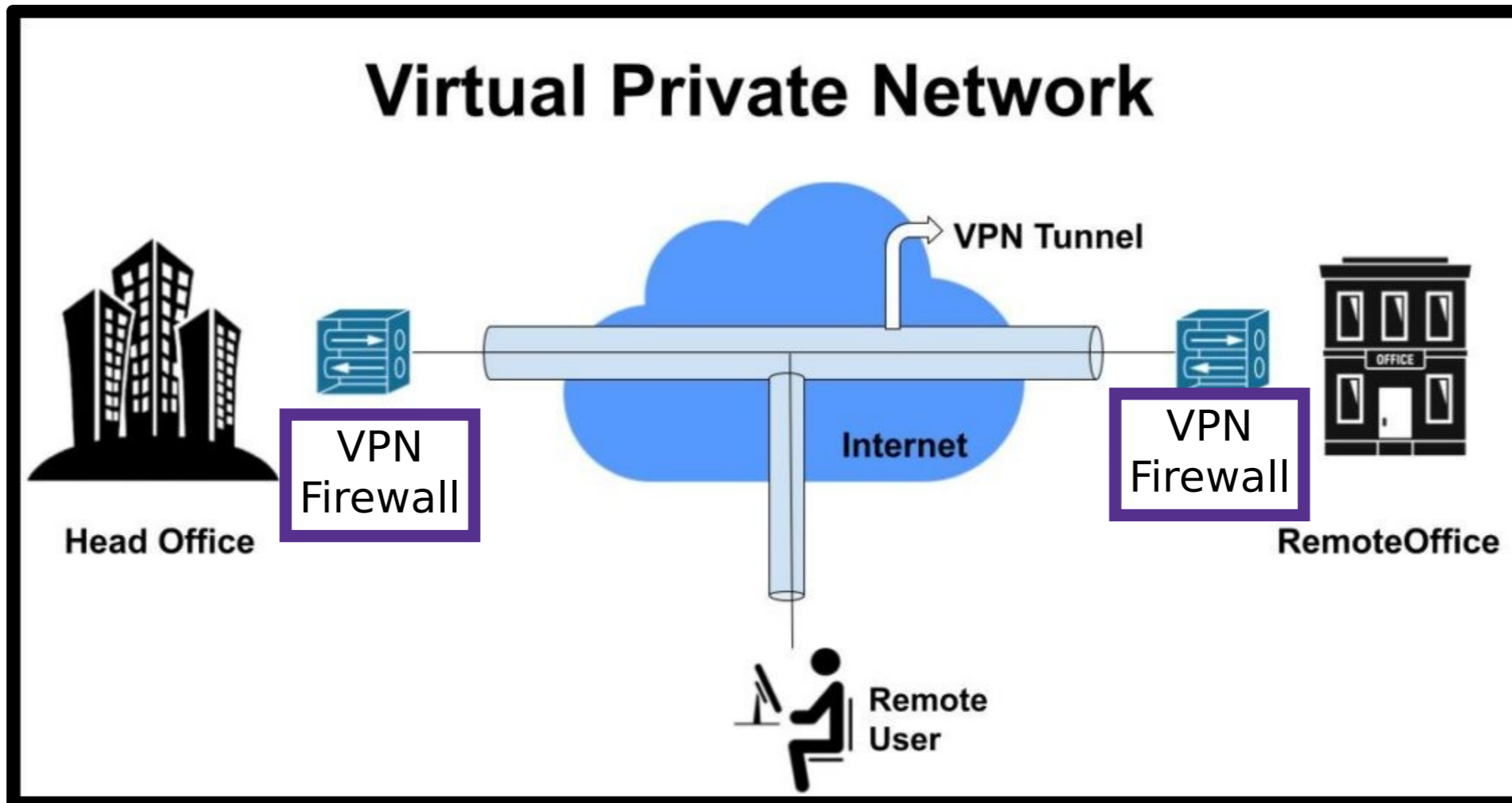

VPN encrypts data to keep it private on public network
- Encrypts at Layer 3: data is in packet

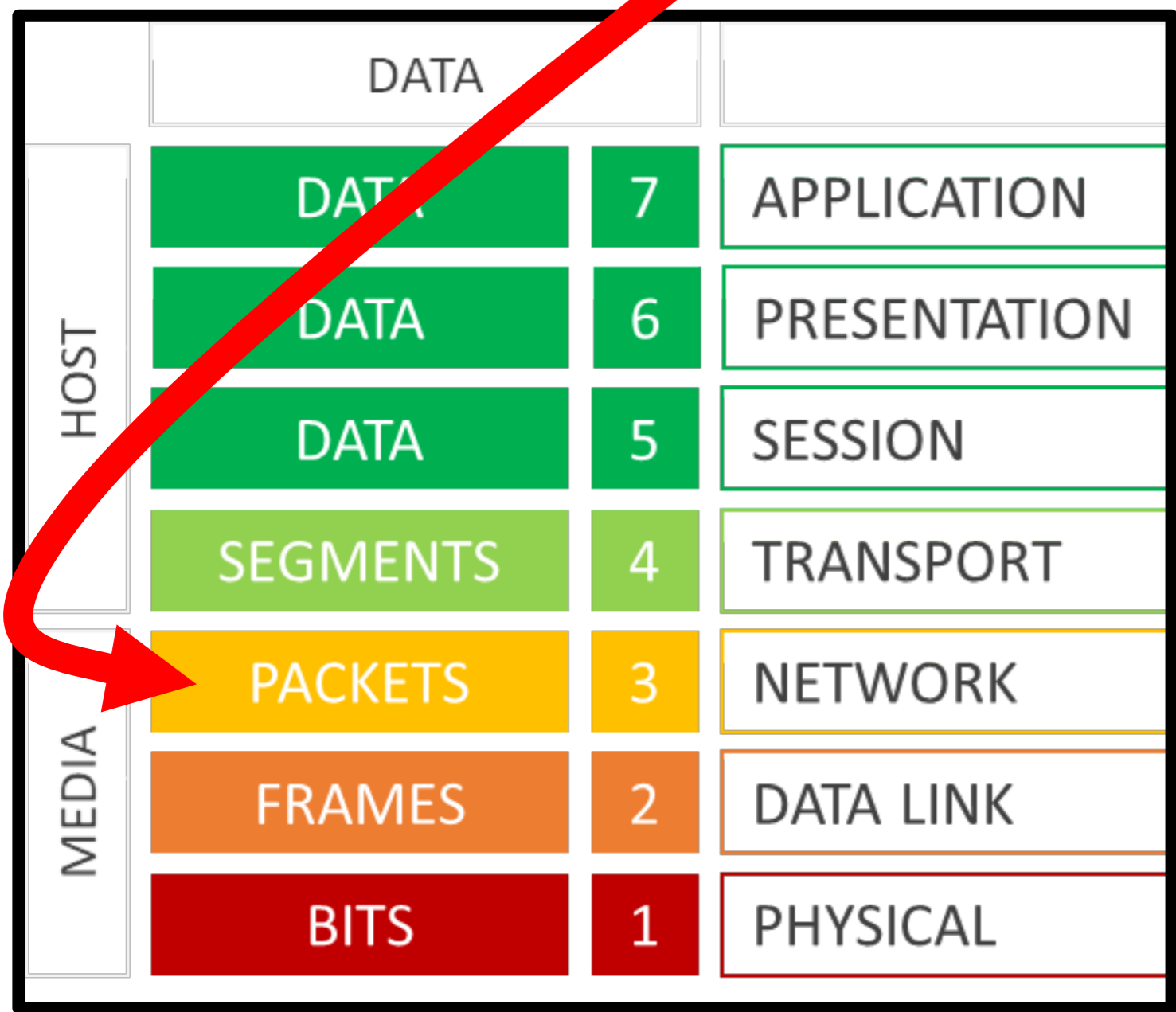

IPSec - Layer 3 Protocol

